

# GC/MSD Pesticide Screening in Strawberries at Tolerance Levels Using Library Searching of Deconvoluted Spectra

## Authors

Anastasia A. Andrianova,  
Bruce D. Quimby, and  
Jessica L. Westland  
Agilent Technologies, Inc.

## Abstract

The Agilent 8890 GC system and Agilent 5977 GC/MSD system were used for the screening of pesticides in strawberries. With proper selection of instrument configuration, operating conditions, sample preparation, and software workflow, the system provides a robust way to identify pesticides in complex matrices. The hardware was optimized for pesticide detection in foods by incorporating pulsed splitless injection, midcolumn backflush, the Inert Extractor EI source, and retention time locking to a database of pesticides and environmental pollutants. The complete analysis was done in two steps. This application note describes the first step in this workflow whereby samples are screened using Agilent MassHunter Unknowns Analysis software, which provides automated deconvolution and library searching to identify any pesticides or other chemicals of concern. Samples of strawberries were purchased from local grocery stores and were used to demonstrate the capabilities of the method.

## Introduction

Trace-level pesticides and environmental pollutants in the food supply remain a worldwide concern and are driving the demand for more rapid and reliable methods of analysis. Part of the challenge is to find technologies that can search for hundreds of pesticides, polycyclic aromatic hydrocarbons (PAHs), and other targets in complex food matrices. Often, methods are aimed at a specific list of compounds that are commonly found in food products. These methods can be very effective but may overlook any residues that are not specifically targeted.

This approach is intended to find as many compounds of concern as possible using a multistep approach. The first step is to obtain mass spectral scan data on the samples with the GC/MSD system retention time locked to a library of pesticides and environmental pollutants containing over 1,000 compounds. The scan data are then processed in Agilent MassHunter Quantitative 10 Unknowns Analysis software, which provides streamlined automated deconvolution and library searching. Previous approaches to processing scan data for library searching relied on comparing a baseline-subtracted apex spectrum of a peak to reference spectra. That approach can work well when there are no chromatographic interferences with the peak. Food samples, however, often contain significant levels of matrix compounds that can interfere with the process, making analyte identification challenging.

Spectral deconvolution is a long-used software approach to removing the ions of coeluting compounds from the spectrum of an analyte. In deconvolution, ion chromatograms are extracted at all masses in the scan range. Ions with chromatographic peaks having the same shape and retention time (RT)

are grouped into components. The responses of ions present in multiple overlapping peaks are apportioned to each peak using a similar process to that in chromatographic integrators. Spectra are then constructed from the components. The deconvolution process greatly reduces or eliminates interfering ions in the analyte spectra.

MassHunter Quantitative 10 Unknowns Analysis has a powerful set of tools to deconvolute the spectra in a scan file and search the components against libraries. Peaks with high library match scores are then inspected as possible hits. If the libraries contain RT or retention index (RI) information, these can be used to filter the search results and provide further evidence of a compound's presence. Generally, the higher the library match score (LMS), and the closer the RT match, the more likely the compound is present. This screening is most effectively done with a spectral library containing RTs or RIs collected under retention time locked (RTL) conditions and with scan data locked to the same time scale. With RTL, RTs usually match those of the library within 0.1 minutes or less. This work assembled a new spectral library of >1,000 compounds with RTs locked to the Agilent pesticides and environmental pollutants MRM database<sup>1</sup> and to Agilent MassHunter Pesticides PCDL and workflow for GC/Q-TOF.<sup>2</sup> MassHunter Unknowns Analysis can automatically process a complete scan file in minutes and produce a report of LMS and RT match data, which is then inspected to determine the compounds present.

Further screening can be done by searching the deconvoluted components against the NIST library. The NIST 17 library contains RIs experimentally determined on semistandard nonpolar columns of the type used here for many of the entries. An alkane RI calibration mix is run with the RT locked pesticide

method and used to create an RI calibration file. MassHunter Unknowns Analysis then searches the deconvoluted spectra through NIST 17, and lists the LMS and RI values for hits as well as the NIST RI values, if available. Although this is a powerful tool, it can lead to a very large list of hits to be inspected because it searches all matrix components.

To demonstrate the utility of this approach, 16 packages of strawberries were purchased in various grocery stores around Cupertino, California, and subjected to analysis with the method. Strawberries often require the application of pesticides to successfully grow an acceptable product. The strawberry samples were extracted with a QuEChERS method, resulting in extracts in acetonitrile as the solvent.

Given the active nature of many of the pesticides, the choice of inlet and injection technique should be optimized. In this case, pulsed hot splitless injection was found to provide good analytical results. Acetonitrile is not a solvent of choice for pulsed hot splitless injection into a GC with the columns used here. Techniques such as solvent vent methods are often required to avoid problems such as poor peak shapes. This method addresses this problem using a low pressure drop inlet liner.

In addition to the inlet-related challenges, there are often matrix-related problems with the analysis. For example, high-boiling matrix contaminants that elute after the analytes can require extended bake-out times to prevent ghost peaks in subsequent runs. The highest boiling contaminants can deposit in the head of the column, requiring more frequent column trimming and adjustment of data analysis time windows from the resulting RT shift. This problem is reduced using a midcolumn backflush configuration.

## Experimental

This system was configured to minimize potential problems with the analysis of pesticides in high-matrix food extracts. The important techniques used were:

- Midcolumn backflushing:** Backflushing is a technique in which the carrier gas flow is reversed after the last analyte has exited the column. After the MS data are collected, the oven is held at the final temperature in post run mode, and the carrier gas flow through the first column is reversed. This reversed flow carries any high boilers that were in the column at the end of data collection out of the head of the column and into the split vent trap. The ability to reverse the flow is provided by the Agilent Purged Ultimate Union (PUU). The PUU is a tee inserted, in this case, between two identical 15 m columns. During the analysis, a small make-up flow of carrier gas from the 8890 PSD module is used to sweep the connection. During backflushing, the make-up flow from the PSD is raised to a much higher value, sweeping high boilers backward out of the first column and forward from the second. For this configuration, the backflushing time was 1.5 minutes.
- 8890 PSD module:** The PSD is an 8890 pneumatics module optimized for backflushing applications. At high pressures during backflushing, the fixed restrictor can have hundreds of mL/min of wasted flow. The PSD will stay at the user-defined setpoint (default 3 mL/min) even at high pressures, which significantly reduces the required gas flow. Also, when the PSD is present in a midcolumn backflush configuration,

the setup for pulsed splitless mode is simplified as the column flow for both column 1 and column 2 will be increased respectively during the pulse.

- RTL:** RTL is an Agilent feature in which a locking compound, in this case chlorpyrifos-methyl, is run on the system. The software then determines the column flow rate required to get precisely the same RT as that in spectral libraries or other spectral databases collected under the locked conditions. This locking results in nearly identical RTs for pesticides across multiple

instruments and platforms, making data analysis and method maintenance much easier. Precise RTs provide a useful filter in the screening process.

- Spectral deconvolution:** The spectral deconvolution features in MassHunter Quantitative 10 Unknowns Analysis software provide an automated means to quickly identify compounds in high-matrix samples using library match scores and precise RT matching.

Figure 1 shows the system configuration used.

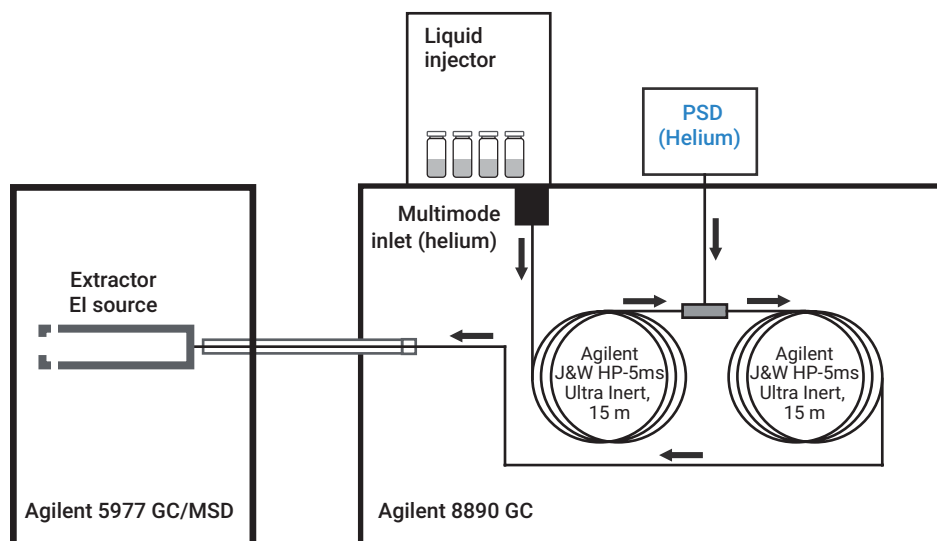

Figure 1. Configuration of the Agilent 8890 GC and Agilent 5977B GC/MSD systems.

Ultra Inert, splitless inlet liner, part number 5190-2293



Ultra Inert, universal, low pressure drop inlet liner, part number 5190-2295



Figure 2. Liners evaluated for pulsed splitless injection

Table 1 lists the instrument operating parameters. Pulsed splitless injections were used to maximize the transfer of the pesticides, especially the active ones, into the column. Initially, problems with analyte peak shapes were encountered due to the use of acetonitrile as the injection solvent. Acetonitrile is known to

be troublesome with splitless injections into the seminonpolar columns used here. The Agilent 5190-2293 single taper Ultra Inert splitless inlet liner (top of Figure 2) is widely used for splitless injection, and it works well with most common GC solvents. With acetonitrile, however, pulsed splitless

injections produced multiple peaks for each analyte. As an alternative, the Agilent 5190-2295 Ultra Inert universal low pressure drop inlet liner (bottom of Figure 2) was found to eliminate the problem, and was used for all subsequent analyses.

**Table 1.** GC/MS conditions for pesticide screening.

GC	
Agilent 8890 GC system with fast oven, auto injector, and tray	
Inlet	
	Multimode inlet
Mode	Pulsed splitless
Injection Pulse Pressure	50 psi until 0.75 minutes
Purge Flow to Split Vent	50 mL/min at 0.7 minutes
Septum Purge	3.0 mL/min
Septum Purge Flow Mode	Switched
Injection Volume	2.0 µL
Inlet Temperature	280 °C
Carrier Gas	Helium
Inlet Liner	Agilent low pressure drop with glass wool
Inlet Liner Part Number	5190-2295
Oven	
Initial Oven Temperature	60 °C
Initial Oven Hold	1 minute
Ramp Rate 1	40 °C/min
Final Temperature 1	120 °C
Final Hold 1	0 minutes
Ramp Rate 2	5 °C/min
Final Temperature 2	310 °C
Final Hold 2	3.0 minutes
Total Run Time	43.5 minutes
Post Run Time	1.5 minutes
Equilibration Time	0.25 minutes

Column 1	
Type	Agilent J&W HP-5ms Ultra Inert (p/n 19091S-431UI)
Length	15 m
Diameter	0.25 mm
Film Thickness	0.25 µm
Control Mode	Constant flow
Flow	1.395 mL/min
Inlet Connection	Split/splitless
Outlet Connection	PSD (PUU)
Post Run Flow (Backflushing)	-12.906 mL/min
Column 2	
Type	Agilent J&W HP-5ms Ultra Inert (p/n 19091S-431UI)
Length	15 m
Diameter	0.25 mm
Film thickness	0.25 µm
Control Mode	Constant flow
Flow	1.595 mL/min
Inlet Connection	PUU
Outlet Connection	MSD
Post Run Flow (Backflushing)	13.32 mL/min
MSD	
Model	Agilent 5977 Series GC/MSD
Source	Inert extractor
Vacuum Pump	Performance turbo
Tune File	ETUNE.U
Mode	Scan
Scan Range	45 to 550 amu
Solvent delay	4 minutes
EM voltage Gain mode	1.0
TID	On
Quad Temperature	150 °C
Source Temperature	280 °C
Transfer Line Temperature	280 °C

## Sample preparation

Sixteen different packages of organic and nonorganic strawberries were purchased from local retail stores and farmer's markets in the Cupertino, CA area. Strawberries were cut into small pieces, frozen, and blended under liquid nitrogen (organic samples were blended first). A QuEChERS sample preparation was used as follows. Ten grams of each sample were weighed into a 50 mL centrifuge tube. Two ceramic homogenizers were added to each centrifuge tube, followed by the addition of 10 mL of acetonitrile (HPLC grade) to each tube. Samples were mechanically shaken for three minutes at 1,500 strokes/min. An EN Method 15662 QuEChERS extraction salt packet (part number 5982-6650) was added to each centrifuge tube. Samples were mechanically shaken for three minutes at 1,500 strokes/min, then centrifuged for five minutes at 5000 rpm. A 6 mL aliquot of the extract was transferred to a QuEChERS Dispersive SPE 15 mL tube (general fruits and vegetables, part number 5982-5056). Samples were vortexed for three minutes at 1,500 strokes/min, then centrifuged for five minutes at 5000 rpm. The sample extracts were transferred to labeled autosampler vials for analysis.

## Results and discussion

### Screening scan data: RTL Pesticide Library

Figure 3 shows the scan TIC of the sample 27 extract. Although the QuEChERS extraction process is effective at recovery of pesticides from the strawberries, it still brings over many matrix compounds, as seen in Figure 3.

The scan file for extract 27 was run through MassHunter Unknowns Analysis with the deconvoluted components searched against the RTL pesticide library. Figure 4 shows the report generated. The report can be sorted by any of the columns, and is shown

sorted by decreasing LMS. Using the fourth entry, fludioxonil, as an example, confidence in it being present is high because it has a high LMS (90.7), and its RT falls within 0.08 minutes of that in the RTL library.

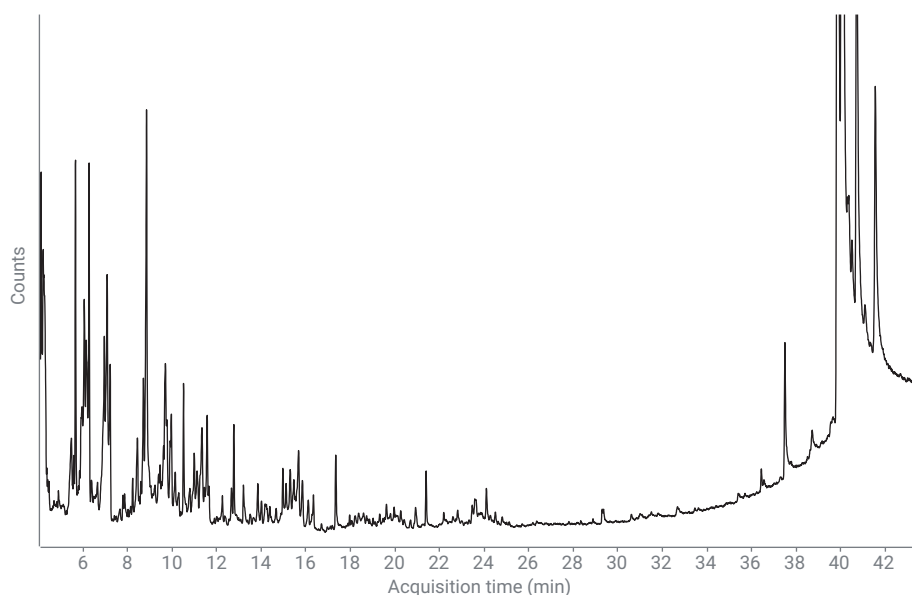

Figure 3. Total ion chromatogram (TIC) of the extract of sample number 27.

Component RT	Compound Name	Match Factor	Delta RT	Formula	Base Peak Area
21.3891	Captan	94.5	0.0399	C9H8Cl3NO2S	52032.5
9.9134	Tetrahydrophthalimide, cis-1,2,3,6-	94.2	0.0906	C8H9NO2	102600.8
29.3490	Bis(2-ethylhexyl)phthalate	91.9	-0.0260	C24H38O4	181695.6
23.3104	Fludioxonil	90.7	0.0816	C12H6F2N2O2	16413.6
28.3328	Bifenthrin	87.9	-0.0078	C23H22ClF3O2	29593.8
20.9145	Cyprodinil	83.8	-0.0115	C14H15N3	60190.5
17.5911	Diisobutyl phthalate	80.4	-0.0091	C16H22O4	9172.2
19.3861	Di-n-butylphthalate	79.1	-0.0041	C16H22O4	23848.5
12.3195	Flonicamid	76.2	0.0895	C9H6F3N3O	15620.9
10.5067	Cashmeran	75.0	-0.0047	C14H22O	856091.4
23.1969	Bisphenol A	66.3	0.0481	C15H16O2	8318.8
12.1518	Diethyl phthalate	64.1	0.0212	C12H14O4	5271.8
21.6057	Fluopyram	63.5	0.0023	C16H11ClF6N...	3253.0
6.7158	Thymol	62.9	-0.0108	C10H14O	9340.1
4.2246	4-Methylphenol	57.5	0.0254	C7H8O	5343.7
12.6725	Fenobucarb	57.4	-0.1625	C12H17NO2	97667.7
5.3488	2,4-Dimethylaniline	56.0	-0.0678	C8H11N	165309.6
7.8016	Eugenol	52.1	0.0144	C10H12O2	5271.3
38.2830	Cinidon-ethyl	51.6	0.1200	C19H17Cl2NO4	2298.6
4.8384	2,4-Dimethylphenol	51.0	0.1166	C8H10O	2609.5

Figure 4. Search results for sample 27 against RTL pesticide library.

Figure 5 shows a portion of the TIC of extract 27 with the identified components in green and the fludioxonil component in red. The TIC shows significant amounts of matrix interferences coeluting with the fludioxonil.

Figure 6 shows the information displayed when inspecting a hit, in this case fludioxonil, in MassHunter Unknowns Analysis. Figure 6A overlays the component profile with the EICs of the ions the software has identified as being part of the spectrum. The overlay is inspected to see if the EICs all have similar shape and RT, as they do here. The spectrum in Figure 6B is the average of the raw spectra over the component profile of the peak. Its purpose is to show the degree of interfering ions from coeluting compounds. The spectrum confirms the large number of interferences suggested by the TIC in Figure 5.

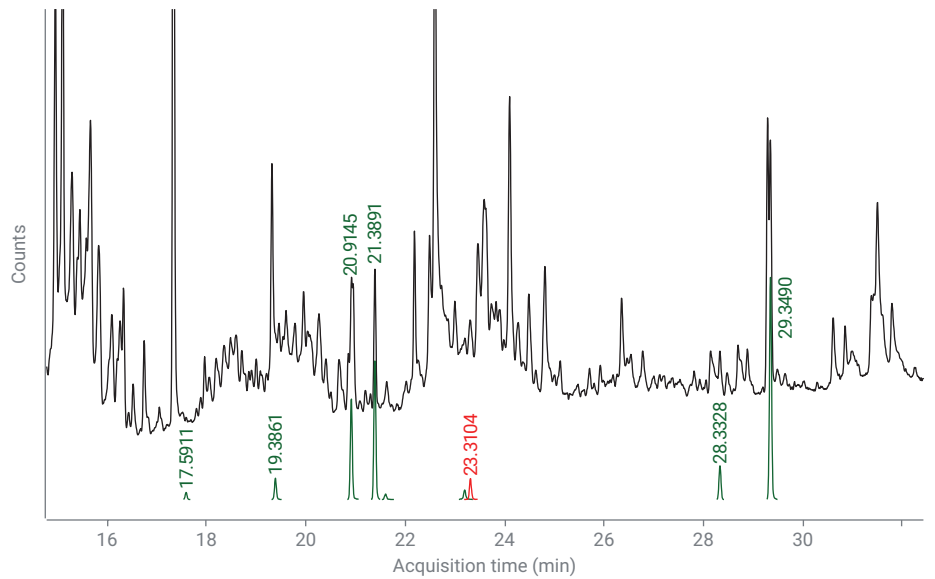

**Figure 5.** TIC of the extract of sample 27 (black trace), identified components (green trace), and fludioxonil component (red trace).

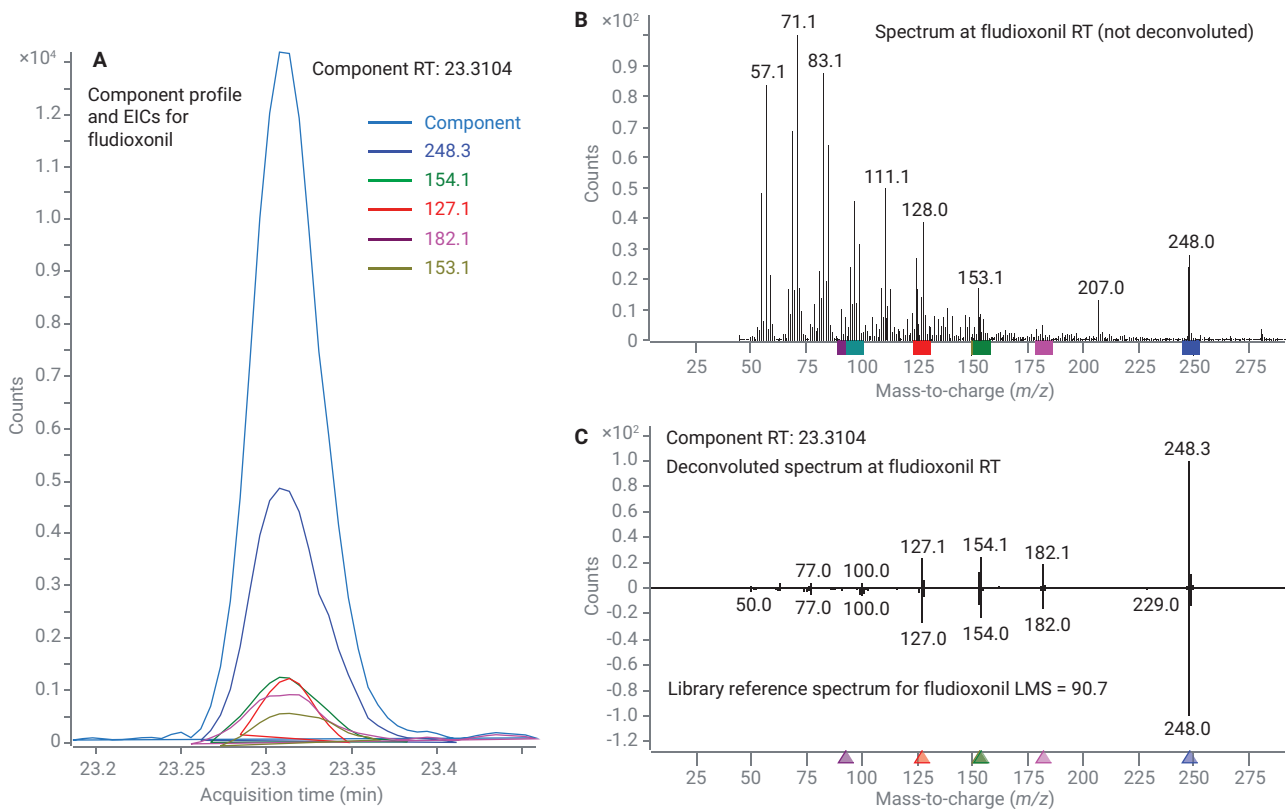

**Figure 6.** Identification of fludioxonil in extract 27 with MassHunter Unknowns Analysis.

Figure 6C shows the deconvoluted spectrum of the component found at the RT of fludioxonil compared to the inverted library reference spectrum. The deconvolution process has removed the interfering ions, producing a high-quality LMS of 90.7.

To generate a list of compounds of interest for quantitation, the inspection process is repeated for all the hits found in MassHunter Unknowns Analysis. The decision as to what compounds to add to the list depends on several factors such as LMS, RT match, the degree of concern for a specific compound, and so forth. The Base Peak Area item is also useful as an indication of the relative size of the response for the listed hit. Typically, compounds with LMS scores less than 65 would be ignored unless the compound is of high concern.

To illustrate the inspection of a hit with a marginal LMS, fludioxonil appears present in sample extract 11 at a level substantially lower than in sample 27.

Figure 7 shows the spectral information displayed in MassHunter Unknowns Analysis for the hit. The component profile had been removed to more clearly show the effect of the signal-to-noise ratio (S/N) of the EICs. Based only on spectral match, this hit would probably be rejected. However, since three of the four principle ions are present in approximately the right ratios, and the RT is within 0.087 minutes of that in the RTL library, the hit may be worthy of adding to the list of compounds to be quantified.

### Screening scan data: NIST 17 library

The >1,000 compound RTL library is convenient for screening because the RT matches are very good and the number of hits to be inspected is limited. However, there are cases when a much broader screen may be desired, such as when a new supplier is being evaluated.

MassHunter Unknowns Analysis can also be used to search the deconvoluted components against the NIST 17 library,

which contains over 260,000 spectra. NIST 17 contains RIs experimentally determined on semistandard nonpolar columns of the type used here for many of the entries. An alkane RI calibration mix was run with the RTL pesticide method, and used to create an RI calibration file. MassHunter Unknowns Analysis then searches the deconvoluted spectra through NIST 17 and lists the LMS and RI values for hits as well as the NIST RI values, if available. Note that this is a very powerful tool, but because it searches all matrix components, can lead to a very large list of hits to be inspected. For example, the screen of extract 27 produced over 400 hits with LMS values >65.

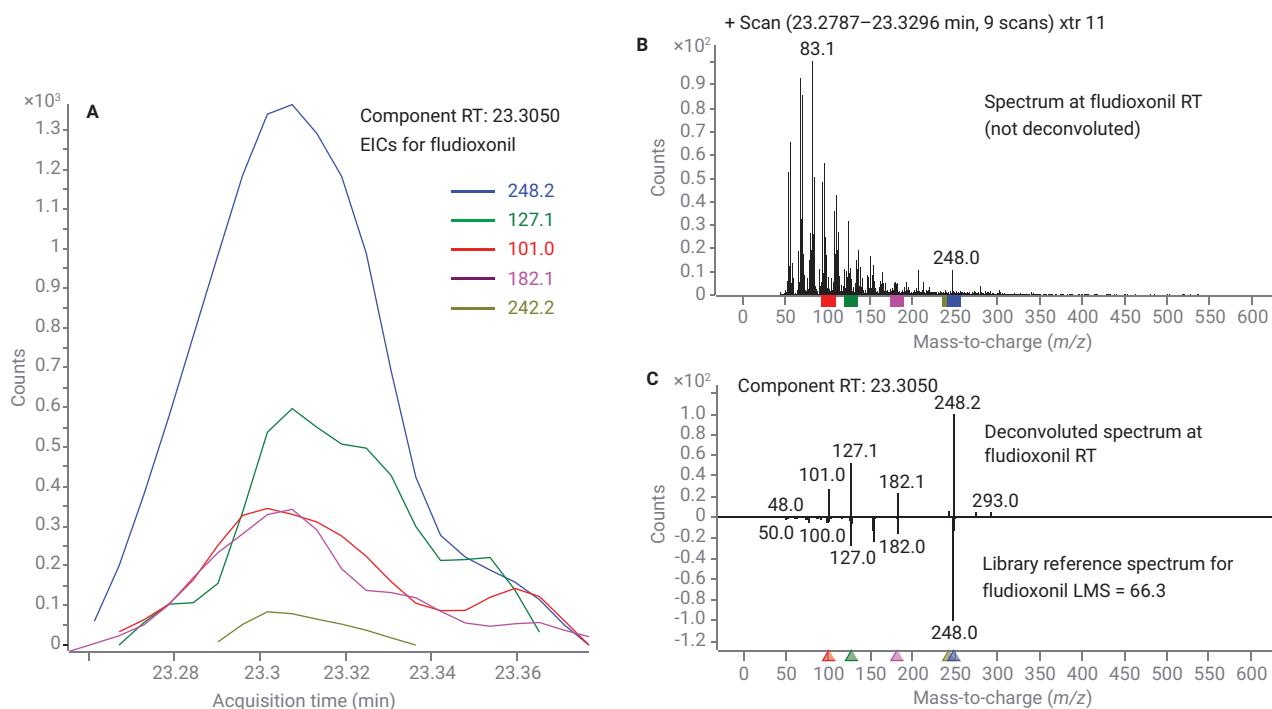

Figure 7. Identification of fludioxonil in extract 11 with MassHunter Unknowns Analysis.



Figure 8 shows a portion of the screen results from NIST 17 for extract 27. The component RI was calculated using the hydrocarbon RI calibration. The Library RI was taken from the NIST entry, and is either the experimental RI for the semistandard nonpolar phase if available or a theoretical value calculated from molecular parameters. The latter is of limited value, as the errors in the predicted RI can be quite large.

In reviewing the NIST 17 results, consideration should be given to the LMS and delta RI values. If the LMS is high, the delta RI is a small percentage of the RI, and the NIST RI is of the experimentally determined type, there is solid evidence the compound may be present.

The NIST 17 screen can serve multiple purposes:

- Confirming identifications of compounds found with the RTL pesticide library screen
- Finding alternative identifications for RTL screen hits with questionable LMS values
- Identifying chemicals not in the RTL screen that may be of concern

In Figure 8, fludioxonil is found with a high LMS value (89.9) and a small delta RI value (of the experimental type) of only -12 compared to an RI of >2,100, confirming the identification found with the RTL pesticide screen.

In Figure 4, showing the RTL pesticide screen results, the fifth entry from the bottom, fenobucarb, has both a poor LMS value (57.4) and poor RT match (-0.1625 minutes). Based on these results, fenobucarb would not be reported. When the same component was searched against NIST 17, a high-quality match to an apparent matrix compound was found, as shown highlighted in blue in Figure 9. Both the LMS (93.2) and delta RI (15) strongly suggest that this hit is correct.

As an example of identifying chemicals not in the RTL screen that may be of concern, in extract 13, a hit for (Z)-13-docosenamide was found with an LMS of 89.1 and an RI delta of 158 out of ~2,700. This compound is a slip agent commonly used in polymer manufacture and is not considered hazardous. It may have come from the plastic packaging the strawberries were purchased in.

The extracts of the strawberry samples were also used in a separate experiment<sup>3</sup> that quantified the pesticides found in the screening process. By comparing the screening results with the quantitation values, an estimate of the amount of pesticide required for identification by the screening process was made.

Component RT	Compound Name	Match Factor	CAS#	Formula	Component RI	Library RI	Delta RI	Base Peak Area
22.8308	Pentanoic acid	62.3	109-52-4	C5H10O2	2154	904	-1250	4734.9
22.9106	Benzene, (1-methyltridecyl)-	63.1	4534-59-2	C20H34	2158	2007	-151	3630.2
22.9124	Z-Phenylbenzamide	58.1	7404-97-9	C19H15NO	2158	2554	396	3630.2
23.0005	Octadecanoic acid	74.4	57-11-4	C18H36O2	2163	2172	9	6180.5
23.1969	Phenol, 4,4'-(1-methylethylidene)bis-	66.4	80-05-7	C15H16O2	2175	2108	-67	8318.8
23.2171	Ethanone, 1-(2-thenyl)-	62.6	88-15-3	C6H6OS	2176	1092	-1084	863.5
23.2828	Ethanol, 2-ethoxy-	66.7	110-80-5	C4H10O2	2179	708	-1471	10732.1
23.3104	Fludioxonil	89.9	131341-86-1	C12H6F2...	2181	2169	-12	16413.6
23.4516	Cyanamide, dibutyl-	67.0	2050-54-6	C9H18N2	2189	1210	-979	17456.0
23.4657	6-Amino-1,3,5-triazine-2,4(1H,3H)-dione	76.1	645-93-2	C3H4N4O2	2190	1512	-678	76448.8
23.4672	6-Amino-1,3,5-triazine-2,4(1H,3H)-dione	75.4	645-93-2	C3H4N4O2	2190	1512	-678	76448.8
23.4780	d-Proline, N-methoxycarbonyl-, undecyl ester	80.3	1000320-7...	C18H33NO4	2191	2222	31	76448.8
23.5804	1-Hydroxy-2-butanone	74.1	5077-67-8	C4H8O2	2196	798	-1398	42935.4
23.5837	3-(Ethylhydrazono)butan-2-one	79.3	1000194-9...	C6H12N2O	2197	1145	-1052	150888.1
23.6310	Pyridin-2,6-diol, diacetate	71.9	1000153-0...	C9H9NO4	2199	1434	-765	18520.8
23.6351	1-[1,2,4]Triazol-1-ylethanone	82.4	15625-88-4	C4H5N3O	2199	988	-1211	40556.0
23.7372	Carbonic acid, eicosyl vinyl ester	66.8	1000382-5...	C23H44O3	2205	2497	292	19284.7
23.7509	1-[1,2,4]Triazol-1-ylethanone	77.2	15625-88-4	C4H5N3O	2206	988	-1218	19284.7
23.8284	1-Nonene, 4,6,8-trimethyl-	74.3	54410-98-9	C12H24	2211	1012	-1199	16170.3
23.9030	Cyclopentanone, 2-oxetyl-	77.6	40566-23-2	C13H24O	2215	1528	-687	12739.3
24.0837	6-Methylcyclohexathiazole	60.3	96963-10-9	C8H11NS	2226	1243	-983	30301.6
24.0862	3,12-Dibora-2,4,11,13-tetraoxatricyclo[12.4.0.0(0...	63.0	1000063-4...	C16H30B2...	2226			30301.6
24.0999	Phenanthrene, 7-ethenyl-1,2,3,4,4a,5,6,7,8,9,1...	58.3	55255-56-6	C20H32	2227	1902	-325	16173.8
24.1046	Benzyl beta-D-glucoside	70.5	1000126-9...	C13H18O6	2227	2461	234	126801.0
24.2760	2-Pyrazoline, 1-isopropyl-5-methyl-	75.6	26964-54-5	C7H14N2	2237	852	-1385	12745.9
24.2983	1,2-Oxaphosphole, 3,5-bis(1,1-dimethylethyl)-2,5...	57.7	56248-43-2	C11H21O3P	2239			2364.2

Figure 8. A partial list of search results for sample 27 against NIST 17 library.

Component RT	Compound Name	Match Factor	CAS#	Formula	Component RI	Library RI	Delta RI	Base Peak Area
12.5084	Phthalic acid, 3,5-dimethylphenyl 4-formylphenyl...	68.2	1000315-7...	C23H18O5	1616	3115	1499	1009.2
12.5626	.alpha.,.alpha.,.alpha.,2-Tetrafluoro-m-tolunitrile	56.5	146070-35-1	C8H3F4N	1618	881	-737	535.1
12.6441	Homovanillic acid	75.8	306-08-1	C9H10O4	1622	1657	35	10789.7
12.6725	Phenol, 4-(3-hydroxy-1-propenyl)-	93.2	3690-05-9	C9H10O2	1624	1639	15	97667.7
12.6736	[1,2,4]Triazole, 4-amino-3-(pyrazol-1-yl)-	58.2	1000316-9...	C5H6N6	1624	1481	-143	53907.0
12.7279	Benzoic acid, 4-[(2,4-dimethoxy-6-pentylbenzoyl)...	71.8	5366-08-5	C28H38O7	1627	3603	1976	3341.6
12.7638	n-Propyl cinnamate	91.9	7778-83-8	C12H14O2	1628	1466	-162	588345.3

Figure 9. A partial list of search results for sample 27 against NIST 17 library.



Table 2 contains the GC amenable pesticides identified in the strawberry extracts, the tolerances for the maximum concentration of a pesticide residue in strawberries established by the US EPA,<sup>4,5</sup> and the estimated amount required for identification by screening. All the pesticides encountered in the strawberry samples could be identified at or below the tolerance levels.

**Table 2.** Estimated ppb of pesticides required for identification with this method.

	<b>Tolerance</b>	<b>ppb Required</b>
<b>Compound</b>	<b>ppb</b>	<b>to ID</b>
Azoxystrobin	10,000	534
Bifenazate	1,500	500
Bifenthrin	3,000	100
Boscalid	4,500	165
Captan	20,000	2,000
Carbaryl	4,000	200
<i>cis</i> -1,2,3,6-Tetrahydrophthalimide	25,000	500
Cyprodinil	5,000	100
Etoxazole	500	100
Fenhexamid	3,000	300
Flonicamid	1,500	300
Fludioxonil	2,000	100
Malathion	8,000	150
Metalaxyl	10,000	100
Myclobutanil	500	500
Novaluron	500	500
Pyrimethanil	3,000	100
Quinoxifen	900	100
Tetraconazole	2,500	150
Trifloxystrobin	1,100	150

## Conclusion

The Agilent 8890 GC system and Agilent 5977 GC/MSD system provide a practical means of identifying pesticides in strawberries. Pulsed splitless injection produces suitably inert sample transfer at the required levels. Midcolumn backflush reduces both the run time and frequency of column trimming. By first screening sample extracts in scan mode using Agilent MassHunter Unknowns Analysis with automated deconvolution and library searching software, pesticides or other chemicals of concern can be found quickly.

The use of RTL also allows results to be easily compared with those obtained on other instruments and MS types. Any compounds of interest found with this system can be compared to results obtained with GC/MS/MS using the Agilent pesticides and environmental pollutants MRM database and to GC/Q-TOF with the Agilent MassHunter Quantitative Analysis and an accurate mass Pesticide Personal Compound Database and Library (PCDL). The use of multiple platforms provides a powerful toolset for addressing the needs of food safety.

## References

1. Westland, J.; Stevens, J. An Optimal Method for the Analysis of Pesticides in a Variety of Matrices. *Agilent Technologies Application Note*, publication number 5991-7303EN, **2017**.
2. Chen, K.; Nieto, S.; Stevens, J. GC/Q-TOF MS Surveillance of Pesticides in Food. *Agilent Technologies Application Note*, publication number 5991-7691EN, **2017**.
3. Andrianova, A.; Westland, J.; Quimby, B. Quantitation of Pesticides in Strawberries at Tolerance Levels Established by the US EPA Using Agilent 8890/7000D and 8890/7010B triple quadrupole GC/MS systems. *Agilent Technologies Application Note*, publication number 5994-0799EN, **2019**.
4. Index to Pesticide Chemical Names, Part 180 Tolerance Information, and Food and Feed Commodities (by Commodity). *US Environmental Protection Agency Office of Pesticide Programs*. December 12, **2012**.
5. USDA, AMS, S&T, MPD - Pesticide Data Program (PDP). PDP Database Search Application – *User Guide*. January **2019**. <https://www.ams.usda.gov/sites/default/files/media/PDPSearchAppUserGuide.pdf>

[www.agilent.com/chem](http://www.agilent.com/chem)

This information is subject to change without notice.