

# Dual Ion Source DUIS-2020 for Simultaneous ESI and APCI Measurement

Technical Report vol.35



## 1. Ion Source Selection

In LCMS measurement, the ionization mode is selected depending on the polarity of the target compounds. For example, Electrospray Ionization (ESI) is generally selected for analysis of high-polarity compounds which are typically found in drugs and pesticides, while Atmospheric Pressure Chemical Ionization (APCI) is selected for compounds having lower polarity (see Fig. 1).

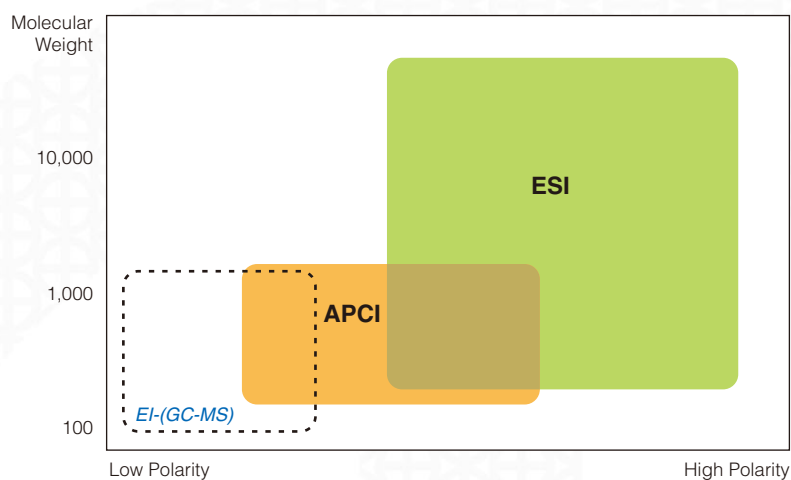

Fig. 1 Selection of Ionization Mode with Respect to Analyte Polarity and Molecular Weight

## 2. Ionization Mode and R&D Efficiency

Selection of the appropriate ionization mode for a given substance is relatively easy if the properties of the substance are known beforehand. However, for someone like a synthesis researcher who handles a wide variety of compounds, the time required for selecting the best ionization mode for each compound can certainly have a negative impact on R&D efficiency. Acquisition of data using both ESI and APCI ionization modes generally requires the use of an ion source (probe) specific to each of the modes. From the standpoint of the researcher looking for any way possible to shorten analysis time, installing a second probe and rerunning an analysis must certainly seem like a needless waste of time. The primary goal of the analyst is to achieve detection of the target compounds as expediently as possible.

### 3. Can ESI and APCI data both be acquired in a single analysis?

For the researcher looking for ways to shorten the time required for analysis and method development, a technique that would combine two different ionization modes would significantly improve both laboratory efficiency and confidence in results. How might sample analysis be conducted using both ESI and APCI ionization concurrently and without severely compromising either technique? Focusing more closely on the ionization mechanisms of ESI and APCI, it becomes clear from the very substantial differences in these ionization principles that achieving this goal requires significant development. As illustrated in Fig. 2, ionization is produced in ESI by applying a high voltage to the capillary through which a stream of ionized analyte molecules exits in nebulized droplet form. In APCI, reaction ions are formed by the electrical discharge around a high voltage corona needle. These ions react in the gas phase with neutral analyte molecules to produce ionization. Since ESI and APCI probes are each designed to optimize their respective technique, a new technology would be required to integrate both of these probes to achieve simultaneous measurement of ESI and APCI data.

### 4. Dual Ion Source DUIS-2020 for Simultaneous ESI and APCI Analysis

The DUIS-2020 is a dual ion source consisting of an integrated probe for analysis using both ESI and APCI techniques. The ionization flow using the DUIS-2020 is as follows, based on the structural illustration of Fig. 3:

- Sample (including mobile phase) is introduced into the probe.
- In the ESI probe, the liquid is nebulized into a fine spray.
- As drying gas is used to evaporate the nebulized spray, ionization by APCI is produced by the corona needle.
- Sample ionized by the ESI and APCI techniques passes through the DL (desolvation line) to enter the vacuum region.

Thus, ESI and APCI ionization are executed concurrently and continuously with the DUIS-2020 without relying on switching between modes. Software control of the individual ESI and APCI voltages allows the chemist to easily select ESI, APCI, or DUIS ionization without changing hardware. Furthermore, the standard ESI probe is used in the DUIS interface, meaning that uncompromised ESI performance is readily achieved.

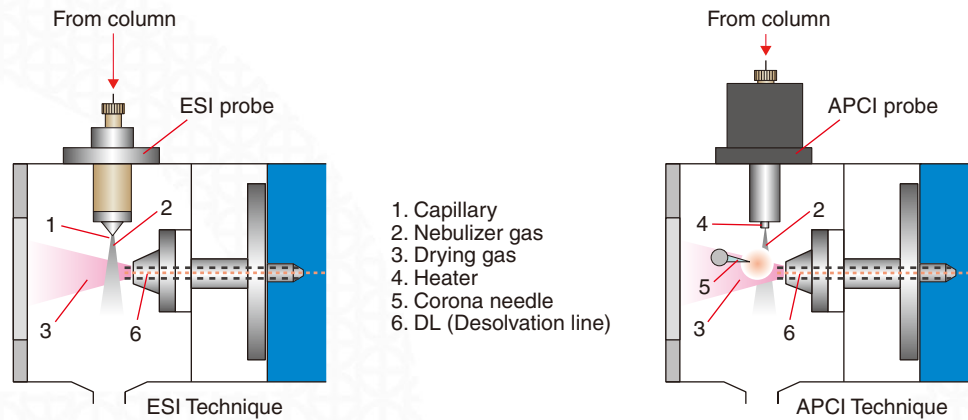

Fig. 2 Structures of ESI and APCI Probes

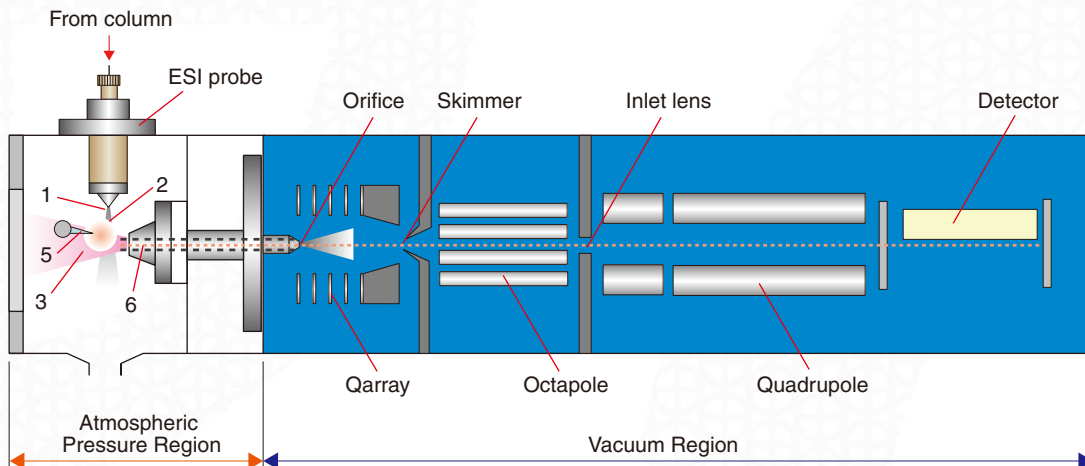
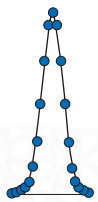

Fig. 3 Structure of LCMS-2020 with Installed DUIS-2020

## 5. DUIS-2020 Optimized for Ultra-High Speed Analysis

The introduction of ultra-high speed analysis has certainly proven effective for improving R & D efficiency. However, along with the benefits of greater efficiency comes the importance of minimizing the loss of data points (digital points acquired during analysis) due to the narrow peak widths associated with fast LC. Polarity switching between negative ion detection and positive ion detection is commonly necessary for unknown or complex samples. Modern improvements in chromatography demand that polarity switching times be only a few milliseconds because even a slight reduction in the number of acquired points can result in reduced sensitivity and distorted peak shapes (see Fig. 5).

The DUIS-2020 interface combines exceedingly rapid polarity switching with continuous ESI and APCI ionization allowing sufficient acquisition of data points across even the narrowest peaks. Whereas polarity switching was previously accomplished by switching positive and negative high voltage power sources arranged in parallel, the LCMS-2020 adopts a new technology (patent pending) in which polarity switching is conducted using serially-arranged positive and negative high voltage power sources. This ultra-fast switching technology achieves 15 ms polarity switching (see Fig. 6).



No. of acquired points:  
20 points

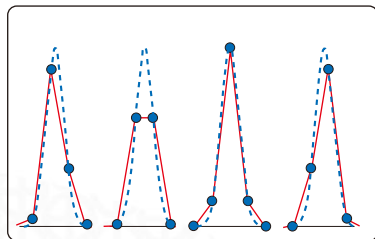

No. of acquired points:  
4 – 5 points

Fig. 5 Number of Acquired Points Affects Peak Shape

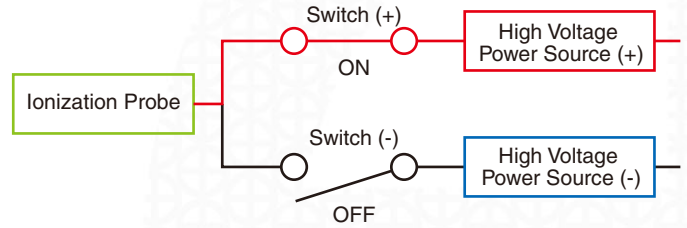

(High voltage power supplies in parallel, positive mode only shown)  
Polarity Switching with Earlier Models (LCMS-2010, LCMS-QP8000)

High Voltage Generation in Positive Ionization Mode

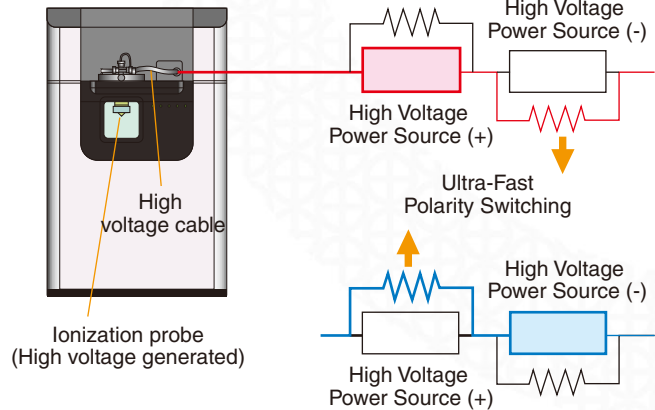

High Voltage Generation in Negative Ionization Mode

Polarity Switching with LCMS-2020

Fig. 6 Polarity Switching Principles

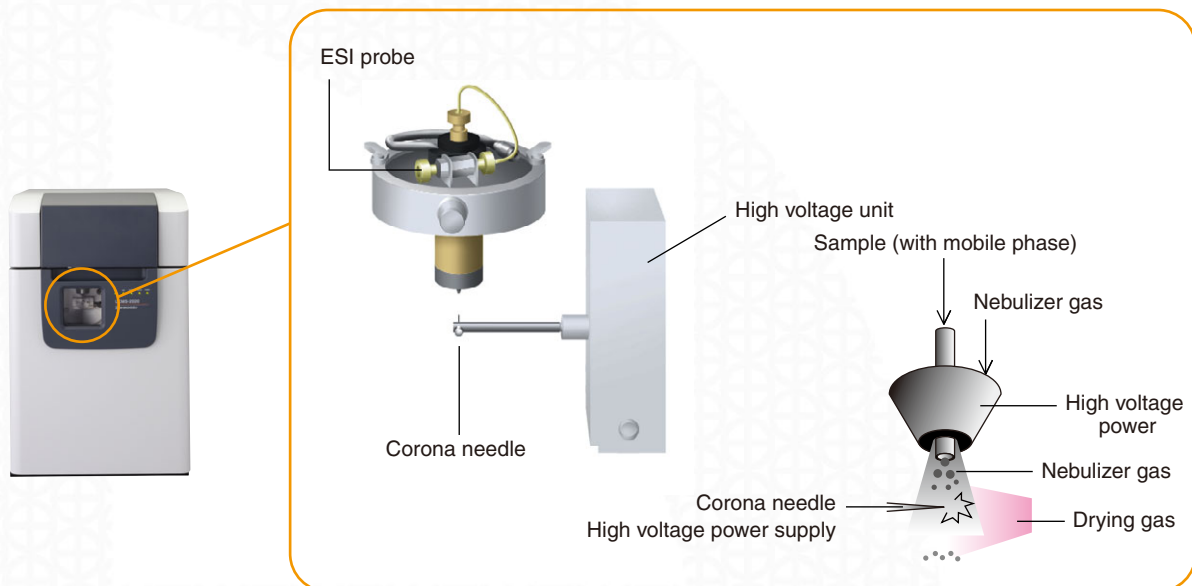

Fig. 4 Structure of DUIS-2020

## 6. Improved Throughput with DUIS-2020

An example of analysis using the DUIS-2020 is shown below. Fig. 7 shows the MS chromatograms obtained from analysis of a sample consisting of water soluble vitamins, thiamine and riboflavin, and a fat soluble vitamin, calciferol. Analysis was first conducted by ESI and by APCI individually, and then by the DUIS-2020 in dual mode.

The results show that good sensitivity is obtained for thiamine and riboflavin using ESI, but that they are scarcely detected using APCI. In addition, calciferol is detected using APCI, but ionization is insufficient using ESI.

But when the dual ion source DUIS-2020 is employed, well-balanced MS chromatograms are obtained.

In conventional systems, the same analysis must be repeated after exchanging the probe, but by utilizing a dual ion source, the analysis is completed in a single run. This demonstrates the power of the DUIS-2020 in providing laboratories with a tool for faster method development and higher sample throughput.

Since the LCMS-2020 utilizes the standard ESI probe as an integral component, upgrading to the DUIS-2020 is simple and cost efficient. Only a corona needle and secondary high voltage power supply need be added to allow simultaneous and continuous ESI and APCI analysis. *Note)*

*Note)* For inquiries regarding additional parts, please contact your Shimadzu Representative.

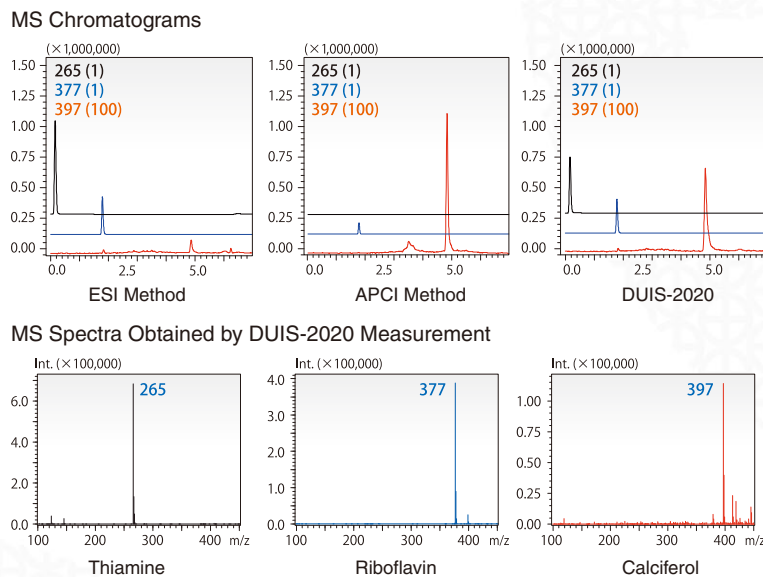

Fig. 7 Analysis of Water Soluble and Fat Soluble Vitamins (3-Vitamin Mixture)

The information contained in this report is protected by copyright by the publisher, Shimadzu Corporation ("Shimadzu"). The sale, use, reproduction or alteration of this information for any purpose is forbidden without Shimadzu's express written consent, which may be granted or withheld at Shimadzu's sole discretion. Moreover, although the information contained herein has been reviewed, Shimadzu makes no warranty or representation as to its accuracy or completeness. Therefore, if some sort of business or contract is to be entered into in reliance upon this published report and the information contained therein, a Shimadzu business representative must be contacted beforehand for authorization and contractual purposes. This report was created based upon information available to Shimadzu when it was issued, and Shimadzu reserves the right to make revisions to the form and content of this published report without prior notice. First Edition: October, 2009

Founded in 1875, Shimadzu Corporation, a leader in the development of advanced technologies, has a distinguished history of innovation built on the foundation of contributing to society through science and technology. We maintain a global network of sales, service, technical support and applications centers on six continents, and have established long-term relationships with a host of highly trained distributors located in over 100 countries. For information about Shimadzu, and to contact your local office, please visit our Web site at [www.shimadzu.com](http://www.shimadzu.com)



SHIMADZU CORPORATION. International Marketing Division

3. Kanda-Nishikicho 1-chome, Chiyoda-ku, Tokyo 101-8448, Japan

Phone: 81(3)3219-5641 Fax: 81(3)3219-5710

URL <http://www.shimadzu.com>