

Dynamic Ultra Micro Hardness Tester

DUH-211/210 Series

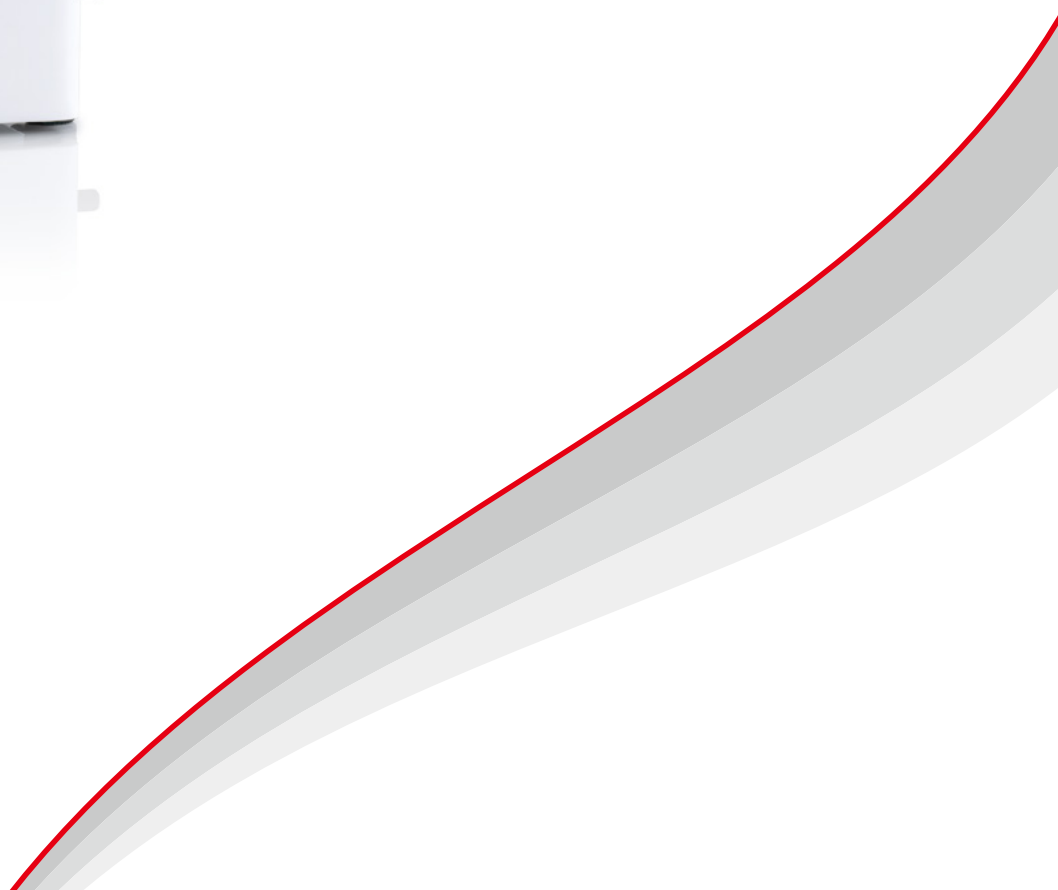

System for Evaluating Thin Films,
Surface-Treated Layers, and Microelectronic Parts

Dynamic Ultra Micro Hardness Tester

DUH-211/211S

DUH-210/210S

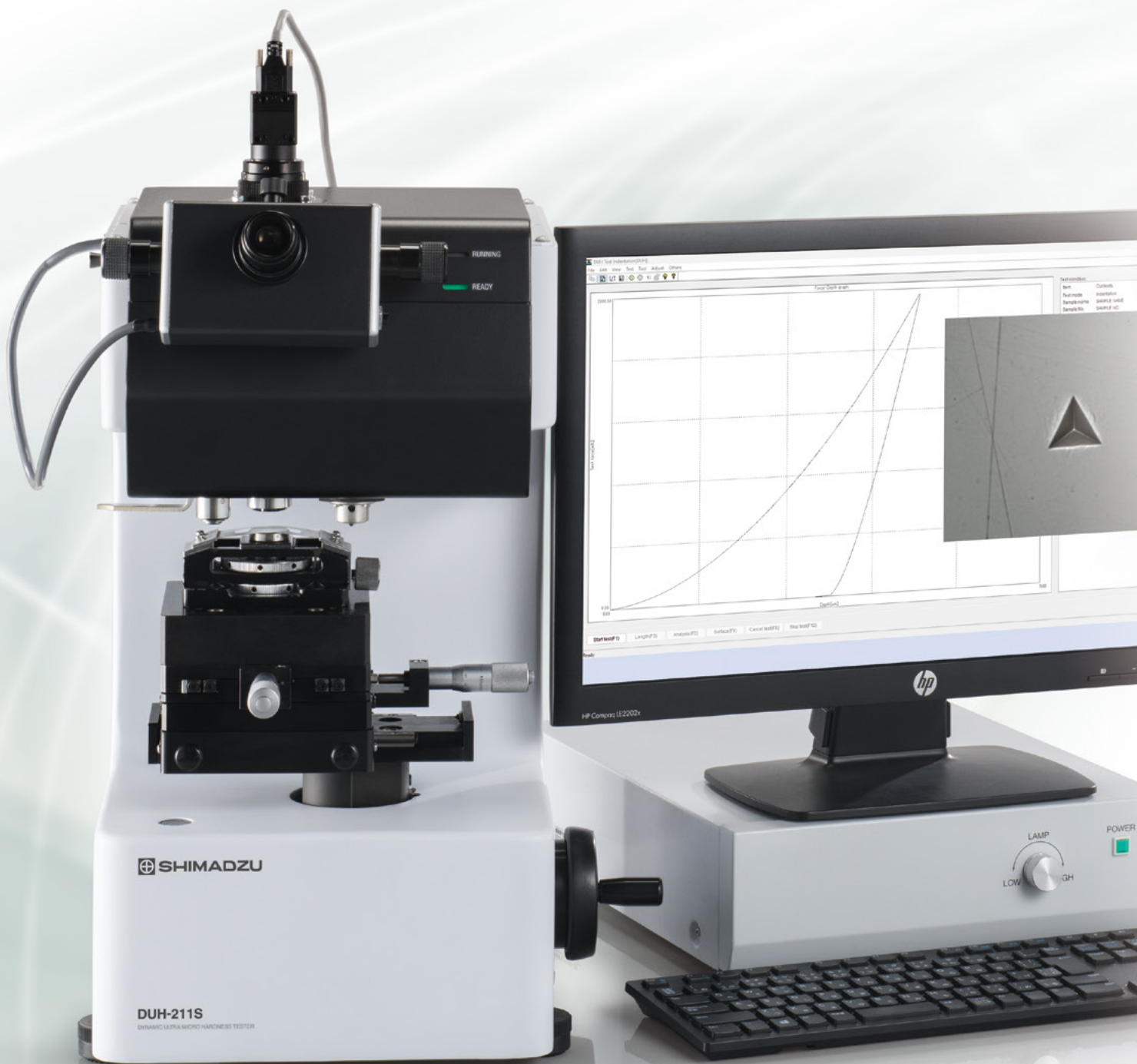

Building on our experience with hardness evaluation technology for the micro range, we have taken our quest for greater precision and ease of use to the next level. Our hardness tester can measure the strength properties of material surfaces and microscopic materials using new evaluation methods specified in ISO standards.

Perform evaluation using the hardness and materials parameters specified in ISO 14577-1 (Annex A) ^{*1)}.

It is possible to evaluate various plastics under the same conditions and on the same scale using ISO/TS 19278 ^{*2)}.

Evaluates hardness of a wide range of materials

- Thin films
- Plastics
- Rubbers and elastomers
- Metallic materials
- Fibers
- Brittle materials
- Microscopic electronic components

Test the surface strength of thin films, surface-treated layers such as ion-implanted layers and nitride layers, as well as nonmetallic materials such as plastics, rubbers, and ceramics.

*1 **ISO 14577-1** *Metallic materials — Instrumented indentation test for hardness and materials parameters — Part 1: Test method Annex A* *Materials parameters determined from the force/indentation depth data set*
 Standard used for new evaluation methods that continuously measure changes in test force and indentation depth which occur when an indenter is pressed into a material, and for the evaluation of material hardness and strength properties such as Young’s modulus and creep deformation

*2 **ISO/TS 19278** *Plastics — Instrumented micro-indentation test for hardness measurement*
 A standard for evaluating the hardness of various plastics on the same scale using instrumented indentation hardness so that the hardness of various plastics can be compared.

Contents

Materials and Applications	P. 4 · 5	Data Processing	P. 9
Features · Measurement Principle	P. 6	Specifications	P. 10
Functions	P. 7	Optional Accessories	P. 11
Evaluation	P. 8 · 9	Related Product	P. 12

Materials and Applications

Thin Films Such as Vapor-Deposited Films and Semiconductor Materials, and Surface-Treated Layers Such as Ion-Implanted Layers and Nitride Layers

As film production technology improves and diversifies, it is becoming increasingly important to evaluate the hardness of thin films and coatings on the surface of materials. These include ion-implanted layers, DLC (diamond-like carbon) films, vapor-deposited films produced by CVD (chemical vapor deposition), PVD (physical vapor deposition) and alumite layer. By using an ultra micro test force to measure depths of less than one tenth of a film's thickness, the DUH tester makes it easy to evaluate the hardness of only the film, without influence from underlying materials.

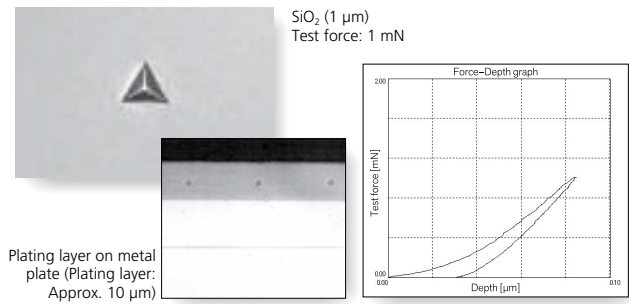

DLC Films

DLC films offer properties such as high hardness, low friction coefficients, wear resistance, electrical insulation, chemical resistance, and infrared light permeability, and are widely used in tools, automotive parts, semiconductor manufacturing equipment parts, and household goods. Measuring the hardness of such films is necessary for determining the optimal film manufacturing parameters and for monitoring their quality, but creating large indentations is not possible. The DUH is perfect for these types of application, because it can evaluate hardness based on the indentation depth using only a small test force.

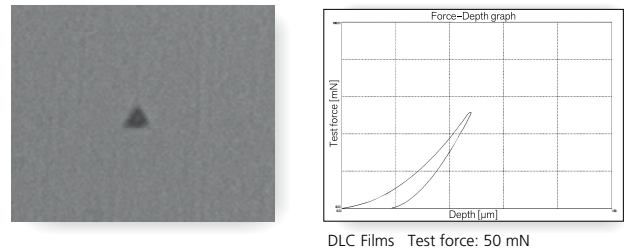

Plastics

An important feature of engineering plastics is hardness. The DUH can measure the hardness of even highly light-absorbent materials, which are difficult to measure using conventional testers.

Engineering plastics offer high strength, heat resistance, and other properties while still providing the advantages of plastics in general such as superior plasticity and ease of processing. As a result, they are commonly used for internal mechanical parts (such as gears and bearings) in consumer electronic products. They provide higher wear resistance, lighter weight, and lower cost than metal parts, and can be mass produced, where hardness is used to improve performance and control quality. However, the low reflectivity of plastics makes it difficult to measure the size of indentations when using conventional hardness testers. In contrast, the DUH is perfect for these applications, because it evaluates hardness based on the test force applied and the resulting indentation depth.

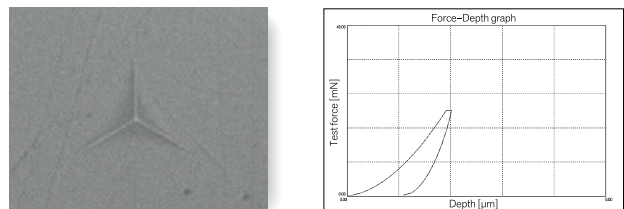
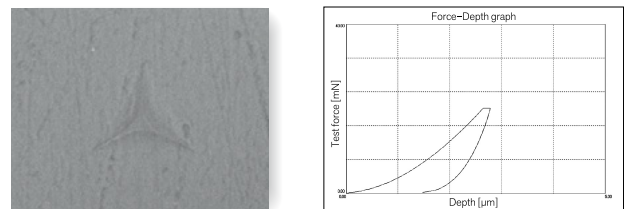
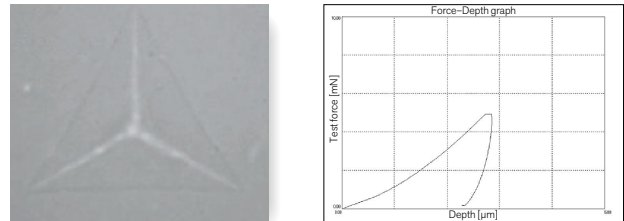

Rubbers and Elastomers

Because indentation depth is used to determine hardness, hardness can be measured using a variety of test forces and the tester can even be used to evaluate deterioration in material surfaces of materials.

Rubber provides a low elastic modulus, high elongation in response to small forces, and high repulsion. Consequently, its raw materials are often mixed with various chemical ingredients to make a variety of products, such as tires, vibration absorbing rubber, and O-rings. Due to the harsh environments where such products are typically used, in addition to evaluating durability, hardness is used to also evaluate surface deterioration. However, conventional hardness testers cannot evaluate the elastic characteristics of rubber because of the indentation after testing. In contrast, the DUH measures both the test force and indentation depth, which makes it the perfect method for evaluating rubber, including its elasticity.

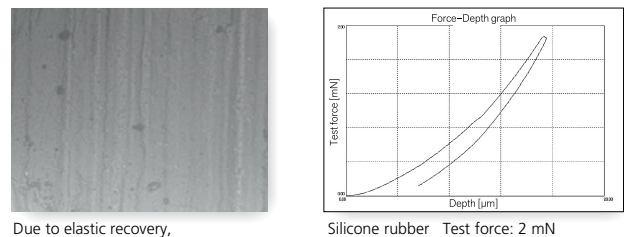

Metallic Materials

Perform micro-region hardness measurement, which has become increasingly difficult as feature sizes have become ever smaller.

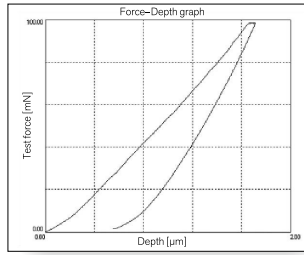
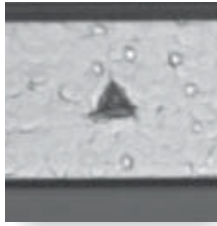

Semiconductor pattern Test force: 100 mN

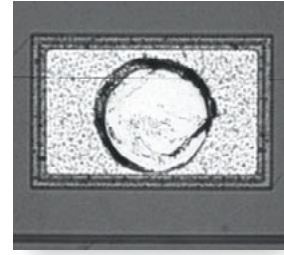

Gold stud bump

Brittle Materials Such as Glass and Ceramics

Use a small test force to evaluate the hardness of brittle materials without generating cracks. Measure the test force required to generate cracks.

Because glass is clear, hard, highly resistant to thermal deformation, and a good electrical insulator, it is used for a wide range of applications, from window glazing and display screens to various substrate materials, such as for CDs. On the other hand, glass also tends to be brittle and thus requires various material and processing method modifications for it to be used in, for example, large thin display applications. Hardness is used to evaluate glass, but large test forces cause cracks and the indentations are not clearly visible. Therefore, the DUH is ideal for evaluating glass, because it determines hardness based on the indentation depth using a small test force.

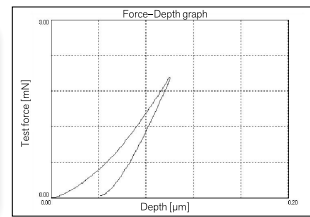

Optical glass Test force: 2 mN

Ultra-Fine Fibers Such as Optical Fibers and Carbon Fibers

Evaluate the strength of specimens taken from composite fiber materials and obtain important information. Measure the hardness of fibers.

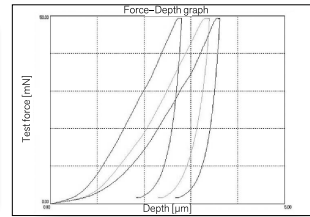
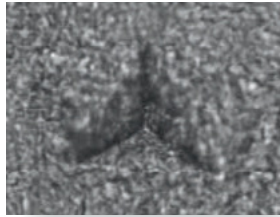

Carbon fiber Test force: 50 mN

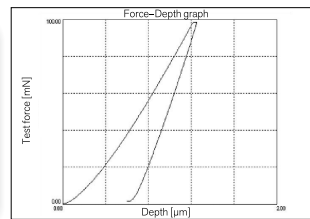

Metal wire Test force: 100 mN

Micro Powders

Advances are being made to create ever finer micro powders in an effort to increase their surface area-to-volume ratios. The strength of powders is evaluated using compression testing, but due to the size of the particles, the DUH is ideal for measuring their hardness in more detail.



Zirconia particles (30 μm)

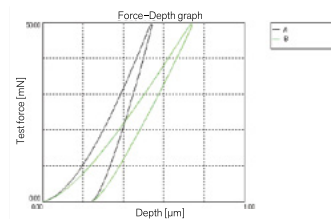

Example of measuring zirconia particles Test force: 50 mN

Features

1. Evaluation of Hardness and Material Parameters in Accordance with Standards (ISO 14577-1 Annex A)

Measure the behavior of a specimen as an indenter is pressed into it and evaluate the hardness, elastic modulus, and amount of work done during indentation, in compliance with ISO 14577-1 (instrumented indentation test for hardness) Annex A.

2. Evaluation of ISO/TS 19278 for Plastics

Measure various plastics under the same measurement conditions in accordance with ISO/TS 19278. (DUH-210/210S)

3. Highly Precise Evaluation of Elastic Modulus

Perform highly precise evaluation of the elastic modulus, using correction based on instrument rigidity and the shape of the indenter tip^{*1}.

4. Low Test Force with Measurement Resolution of 0.196 μN

Control the test force using a high resolution of 0.196 μN. This allows measurement of material strength properties in micro regions and in the outermost surfaces of specimens.

5. Ultra-Wide Test Force Range of 0.1 to 1,961 mN

Use a wide test range of 0.1 to 1,961 mN for measurement, and test a variety of industrial materials, including rubber, plastics, and ceramics.

6. High-Precision Measurement of Indentation Depth

No need to measure the actual indentation. Specimen indentation depth can be measured in units of 0.0001 μm for depths up to 10 μm. (in the case of DUH-211S/211)

7. Supports a Wide Range of Testing Methods (For DUH-211S/210S)

Record the relationship between the test force and the indentation depth. Test both the unload and load processes. Use the DUH-211S/210S to perform cyclic load-unload tests and step load-unload tests.

8. Supports Vickers Hardness Test

A function to measure the length of diagonals is provided as a standard feature. This function allows you to measure the hardness that corresponds only to plastic deformation, Vickers hardness, and Knoop hardness. (A Vickers indenter and Knoop indenter are available as options.) Maximum microscope magnification is 500× (1000× is available as an option).

*1 Indenter tip shape correction is only available for the 115-degree triangular pyramid indenter. Shape correction is not available for other indenters.

Measurement Principle

Electromagnetic force is used to press an indenter (standard type: 115° triangular pyramid) against a specimen. Pressing force is increased at a constant rate, from 0 to the preset test force. Indentation depth is automatically measured as the indenter is pressed against the specimen. This allows dynamic measurement of changes that occur in the specimen's resistance to deformation during the indentation process, and obtains a wide variety of data. During indentation the DUH-211/210 Series measures dynamic hardness and evaluates the hardness that corresponds to both plastic and elastic deformation. Also, if the indentation size is large enough to be observed with a microscope, hardness can be calculated using just the plastic deformation, by measuring the diagonal length of the indentation.

Expressions for Dynamic Hardness

(1) 115° triangular pyramid indenter (standard) $DHT_{115} = 3.8584 \times F / h^2$

(3) Vickers indenter (option) $DHV = 3.8584 \times F / h^2$

(2) 100° triangular pyramid indenter (option) $DHT_{100} = 15.018 \times F / h^2$

(4) Knoop indenter (option) $DHK = 1.5583 \times F / h^2$

Even though the theoretical unit for these hardness expressions is kgf/mm², it is normally not used.

Expressions for Martens Hardness (ISO 14577-1 Annex A)

(1) 115° triangular pyramid indenter (standard) $HM_{115} = 1000 F / 26.43 \times h^2$ [N/mm²]

(2) Vickers indenter (option) $HMV = 1000 F / 26.43 \times h^2$ [N/mm²]

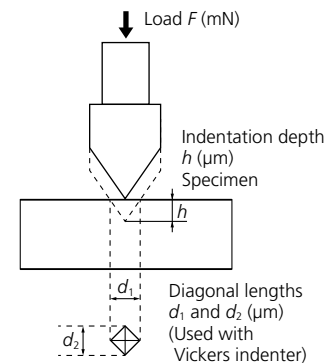

Hardness Expressions Based on Diagonal Length

(1) 115° triangular pyramid indenter (standard) $HT_{115} = 160.07 \times F / d^2$

(2) 100° triangular pyramid indenter (option) $HT_{100} = 121.53 \times F / d^2$

(3) Vickers indenter (option) $HV = 189.10 \times F / d^2$

(4) Knoop indenter (option) $HK = 1451.1 \times F / d^2$

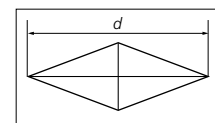
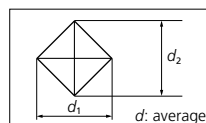
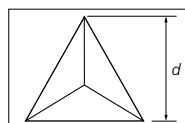

Functions

Combines Easy Operability and High-Level Data Processing Functions

Model used to perform three basic tests: [DUH-211/DUH-210](#)

Advanced model provides seven test modes: [DUH-211S/DUH-210S](#)

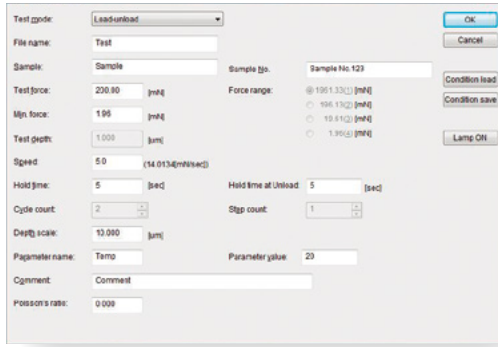

Parameters required for each type of test can be viewed at a glance.

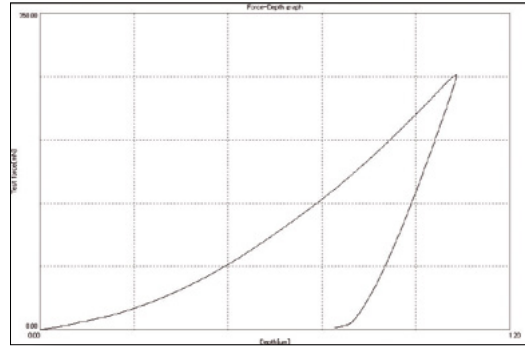

Test Types

Item	DUH-211/210	DUH-211S/210S
1. Load-Hold Test	✓	✓
2. Load-Unload Test	✓	✓
3. Cyclic Test	✓	✓
4. Depth Setting Test	—	✓
5. Depth Setting Load-Unload Test	—	✓
6. Step Load Test	—	✓
7. Step Load-Unload Test	—	✓

Indentation size can be measured in tests 1, 2, 4, and 5.

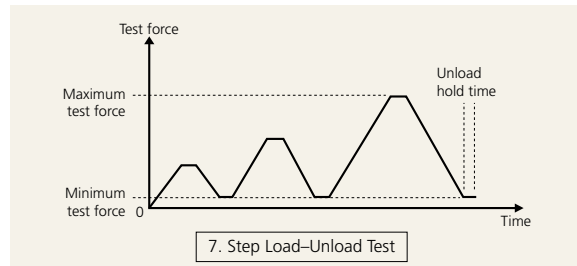
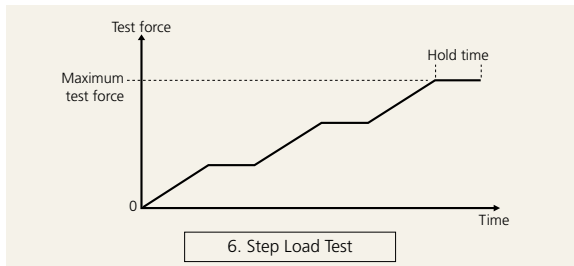
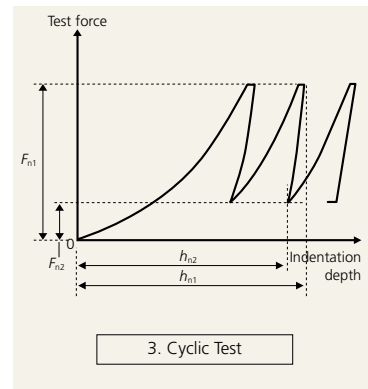
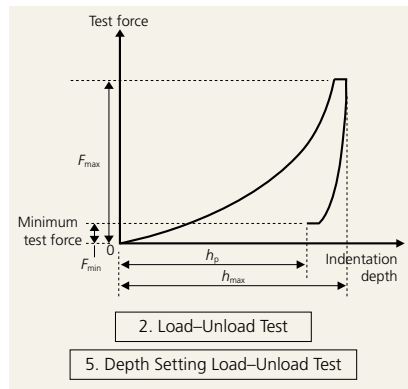
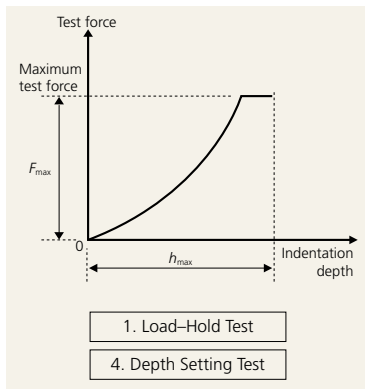

Evaluation

ISO 14577-1 (Annex A) Compliant Evaluation (Instrumented Indentation Test for Hardness)

Relationship between test force and indentation depth during indentation process can, in accordance with ISO 14577-1 (Annex A), be used to evaluate hardness, elastic modulus, and amount of work done.

HM : Martens hardness

HM_s : Martens hardness obtained from gradient of graph of test force versus depth

H_{IT} : Indentation hardness

E_{IT} : Indentation elastic modulus

C_{IT} : Indentation creep

η_{IT} : Indentation work rate

HV* : Vickers hardness obtained by converting H_{IT}

1. Indentation Elastic Modulus (E_{IT})

Definition of indentation elastic modulus (E_{IT}) states that E_{IT} is obtained from the inclination of the tangent used to calculate the indentation hardness (H_{IT}), and is equivalent to Young's modulus.

$$\frac{1}{E_r} = \frac{1 - \nu_s^2}{E_{IT}} + \frac{1 - \nu_i^2}{E_i}$$

$$S = dP/dh = 2 \cdot E_r \cdot A_p^{0.5} / \pi^{0.5}$$

$$A_p = 23.96 \cdot h_c^2$$

$$h_c = h_{max} - 0.75(h_{max} - h_r)$$

If Poisson's ratio for the specimen is set in the test parameters, the DUH-211/210 Series calculates E_{IT}. Otherwise, the DUH-211/210 Series calculates (1 - ν_s²)/E_{IT}.

Here,

E_r: Converted elastic modulus based on indentation contact

E_i: Young's modulus for indenter (1.14 × 10¹² N/m²)

ν_i: Poisson's ratio for indenter (0.07)

E_{IT}: Indentation elastic modulus

ν_s: Poisson's ratio for specimen

S: Inclination at start of unloading (inclination of straight-line approximation)

A_p: Projected contact area (23.96 is a constant that applies when using a 115° triangular pyramid indenter)

h_c: Depth of the contact of the indenter with the test piece at F_{max}

h_r: Point of intersection of the tangent to curve b at F_{max} with the indentation depth-axis

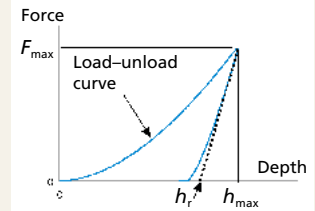

2. Plastic and Elastic Portions of Indentation Work (η_{IT})

A portion of the total mechanical work performed by indentation, W_{total}, is consumed due to plastic deformation, W_{plast}. The remaining portion of the total mechanical work corresponds to elastic deformation, W_{elast}, which is released when the test force is unloaded. This work is defined by W = ∫ Fdh.

$$\eta_{IT} = \frac{W_{elast}}{W_{total}} (\%)$$

$$W_{total} = W_{elast} + W_{plast}$$

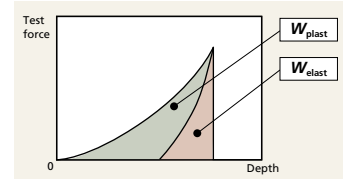

Test Examples

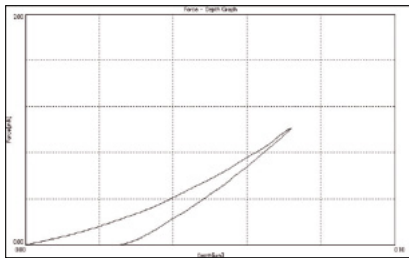

Specimen: Fused silica
Test force: 1 mN

Load-unload Result											
SEQ	F _{max} [mN]	h _{max} [μm]	h _p [μm]	h _r [μm]	HMT115 [N/mm ²]	HMs [N/mm ²]	HIT [N/mm ²]	E _{IT} [N/mm ²]	C _{IT} [s]	nit	
1	1.01	0.0717	0.0266	0.0369	4237.061	6066.186	8668.442	6.828e+004	0.143	68.348	
2	1.01	0.0745	0.0277	0.0374	3880.625	6600.262	8302.861	6.782e+004	0.014	70.336	
3	1.01	0.0704	0.0257	0.0359	4086.280	4713.079	8501.700	6.809e+004	0.519	70.931	
Average	1.01	0.0732	0.0269	0.0362	4165.615	5072.849	8501.034	6.809e+004	0.092	70.932	
Std. Dev.	0.002	0.001	0.001	0.001	122.310	327.581	104.860	302.850	0.390	0.474	
CV	0.188	1.887	4.614	3.000	2.884	7.844	2.172	1.222	110.988	0.679	

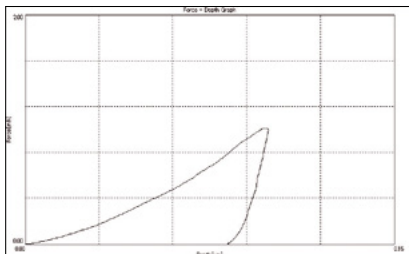

Specimen: Copper alloy
Test force: 1 mN

Load-unload Result											
SEQ	F _{max} [mN]	h _{max} [μm]	h _p [μm]	h _r [μm]	HMT115 [N/mm ²]	HMs [N/mm ²]	HIT [N/mm ²]	E _{IT} [N/mm ²]	C _{IT} [s]	nit	
1	1.01	0.0309	0.0020	0.0034	2442.736	2295.512	3107.330	1.295e+005	3.450	15.231	
2	1.01	0.0368	0.0036	0.0056	2540.487	3058.510	3271.788	1.246e+005	2.284	14.264	
3	1.01	0.0347	0.0027	0.0041	2876.310	2261.668	3661.668	1.177e+005	2.688	16.024	
Average	1.01	0.0304	0.0020	0.0050	2559.007	3176.140	3310.431	1.239e+005	2.810	15.223	
Std. Dev.	0.001	0.003	0.003	0.004	117.048	104.964	224.724	5900.380	0.595	0.937	
CV	0.099	2.708	3.940	4.966	4.595	3.306	6.776	4.765	21.208	6.499	

ISO/TS 19278 Compliant Evaluation (In the case of DUH-210/210S)

Unlike the conventional hardness test standards for plastics, it is possible to compare the hardness of various plastics from rigid plastics to semi-rigid plastics under the same conditions and at the same scale. The software provides a dedicated mode for easy testing.

Test force:	500 mN
Load/Unload time:	30 s each
Holding time:	40 s
Number of tests:	5 or more
Hardness used for evaluation:	H_{IT}

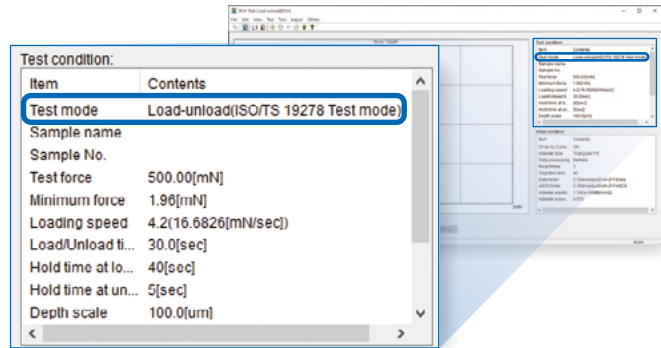

Evaluation Using the Tangent Depth Method

Evaluation based on the Tangent Depth method* is also supported, using the indentation modulus E_{IT} (h_r) and the equivalent indentation Vickers hardness HVI (IW). The Tangent Depth method is an analysis technique developed to provide results that more closely approximate the elastic modulus (Young's modulus) obtained from tensile testing. By using the elastic modulus derived from tensile tests of bulk materials as a reference, this method enables easier comparison of the elastic modulus of plated layers and coating films. In addition, the Tangent Depth method introduces the concept of equivalent indentation Vickers hardness, which was developed as a converted hardness value that provides better agreement than conventional methods for thin specimens where standard Vickers hardness testing is difficult to apply.

* Tangent Depth Method is based on following papers.

- *Journal of Material Testing research Association of Japan* Vol. 62 No. 2 April 2017, pp. 68–77
 Proposal for ISO 14577 – Part 1: Test method (Verification of the calculation method of Young's modulus for wide range of materials and test forces with already calibrated machine frame compliance in its testing system)
- *Journal of Material Testing research Association of Japan* Vol. 65 No. 1 January 2020, pp. 4–17
 Calculation theory of the Equivalent Indenting Vickers hardness HVI(IW) and Implementation for many kinds of material and test force ranging from 10 mN to 1960 mN with Berkovich indenter in the Instrumented Indentation Test

Data Processing

Simply set the required items to obtain the desired information.

Data Processing Items

- Results display
- Data output for test force and depth
- Graph output for test force and depth
- Graph output for hardness and depth
- Graph output for hardness between 2 points and depth
- Graph output for depth and time
- Graph output for hardness and test force
- Graph output for depth squared and test force
- Hardness calculation based on preliminary test force
- Graph output for hardness and parameters
- Calculation of converted hardness values
- Repeated changes of surface detection points
- Calculation of elastic modulus
- ASCII file output

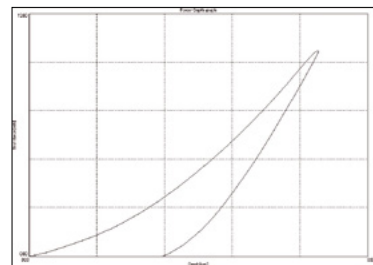

SEQ	Fmax [mN]	hmax [um]	h _p [um]	h _r [um]	HMT115 [N/mm ²]	HMe [N/mm ²]	HIt [N/mm ²]	EIt [N/mm ²]	CV	err
1	10.16	0.2560	0.1192	0.1590	5625.717	4590.396	13203.229	1.007e+006*	1.630	47.298
2	10.16	0.2560	0.1216	0.1596	5715.410	4709.610	12466.966	1.006e+006*	1.345	56.296
3	10.16	0.2560	0.1206	0.1590	5728.604	4621.880	12636.131	1.006e+006*	1.815	56.413
4	10.16	0.2562	0.1183	0.1571	5765.514	4771.402	12660.714	1.006e+006*	1.795	46.380
5	10.13	0.2566	0.1261	0.1666	5724.657	4746.406	12255.552	1.025e+006*	1.634	56.450
Average	10.16	0.2565	0.1207	0.1574	5762.132	4693.238	12704.522	1.006e+006*	1.764	56.555
Std. Dev.	0.015	0.001	0.003	0.002	45.828	82.258	204.030	740.270	0.082	0.420
CV	0.152	0.400	2.367	1.964	0.797	1.762	1.606	0.660	4.629	0.712

Example of test results display (load-unload test)

Specifications

Model		DUH-211	DUH-211S	DUH-210	DUH-210S
Loading Unit	Loading Method	Electromagnetic coil			
	Test Force Range	Full scale of 0.1 to 1,961 mN			
	Test Force Accuracy	±19.6 μN or ±1% of displayed test force, whichever is greater			
	Minimum Measurement Increment	0.196 μN (for a test force not exceeding 1.96 mN)			
Displacement Measurement Unit	Measurement Method	Differential transformer			
	Measurement Range	0 to 10 μm		0 to 100 μm	
	Minimum Measurement Increment	0.0001 μm		0.001 μm	
	Linearity	±2% of full scale (20 μm)		±2% of full scale (150 μm)	
Indenter	Type	Triangular pyramid indenter with tip angle of 115° (Vickers indenter and Knoop indenter are available as options.)			
	Tip Radius	0.1 μm max.			
Optical Monitor	Total Magnification (microscope)	×500			
	Objective Lens	×50 (Up to 2 lenses can be attached.)			
	Eyepiece	×10			
	Lighting Method	Reflected illumination			
	Light Source (lamp)	LED: 3 W, 3 V			
Micrometer	Collimation Method	Direct connection between encoder and control handle; synchronized movement of two indexes			
	Detector	Optical encoder			
	Effective Measurement Range	200 μm (with ×50 objective lens)			
	Minimum Measurement Increment	0.01 μm/pulse			
Specimen Stage	Vertical Distance	Approx. 60 mm			
	Area	Approx. 125 (W) × 125 (L) mm			
	Stage Movement Range	25 mm in both X and Y directions			
	Specimen Holder	Specimen dimensions (i.e., 8 (thickness) × 30 (width) mm) when thin-sample attachment (type 3) is used			
Test Modes	Load-Hold Test	✓	✓	✓	✓
	Load-Unload Test	✓	✓	✓	✓
	Cyclic Test	✓	✓	✓	✓
	Depth Setting Test	—	✓	—	✓
	Depth Setting Load-Unload Test	—	✓	—	✓
	Step Load Test	—	✓	—	✓
	Step Load-Unload Test	—	✓	—	✓
Required PC Specifications	OS	Windows® 11 Pro (64 bit edition)			
	Disk Drives	CD-ROM drive			
	Expansion Bus	PCI Express ×1 (full-length), 2 slots min. more than one ×1 slot is required (or slot size ×2 or more)			
Utilities	Power Supply	Single phase, AC 100–115 V ± 10%, AC 230 V ± 10% (Ground resistance 100 Ω max.)			
	Power Consumption	Approx. 100 W (not including power consumption of PC)			
	Grounding	The ground terminal on 3-prong connectors must be properly grounded with grounding resistance at 100 Ω or less.			
	Temperature	Recommended temperature: 23±1°C Allowable range: 10°C to 35°C			
	Vibration	Horizontal vibration: 0.017 Gal max. (at 10 Hz or more), 0.01 μm max. (at less than 10 Hz) Vertical vibration: 0.010 Gal max. (at 10 Hz or more), 0.005 μm max. (at less than 10 Hz)			
	Humidity	20 to 60% max. (no condensation)			
Dimensions and Weight	External Dimensions	Main unit: Approx. 355 (W) × 405 (D) × 530 (H) mm Control unit: Approx. 315 (W) × 375 (D) × 110 (H) mm			
	Weight	Main unit: Approx. 60 kg Control unit: Approx. 5 kg			

Standard Configuration

Name	P/N	Quantity
Hardness Tester (main unit)		1
Objective Lens (×50)	344-89964-40	1
Triangular Pyramid Indenter (tip angle: 115°)	340-47013	1
Specimen Stage (XY stage)		1
Micrometer Head	347-24205-41	2
Specimen Holder	344-17737-40	1
Control Unit		1
Accessories (Cords, AC adapters, tools, installation disk)		1 set

External Dimensions

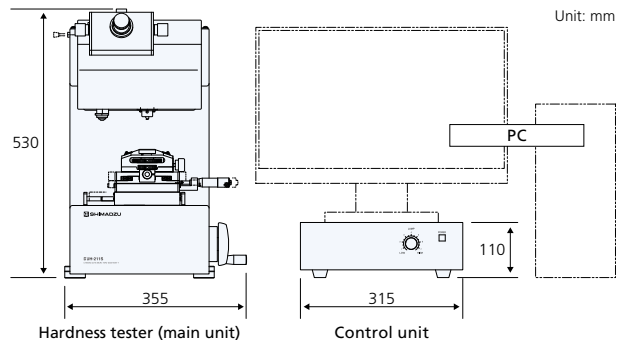

Optional Accessories

Length Measurement Kit (Color or Monochrome)

Length measurement kit, color: P/N 347-24778-44
 Length measurement kit, monochrome: P/N 347-24778-43

Microscope images of the specimen surface can be displayed on the PC screen. Measure the size of indentations on the screen and save the images. Maximum magnification factor is $\times 1300$ (when using 21.5-inch widescreen display and an objective lens with a magnification factor of 50). This accessory can be used with computers designated by Shimadzu.

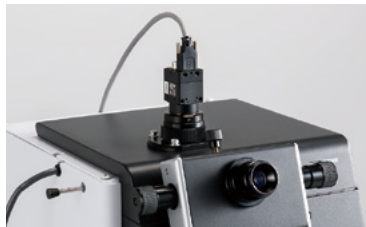

Objective Lens

$\times 100$ objective lens: P/N 344-89977-40
 $\times 40$ objective lens: P/N 347-25400
 $\times 20$ objective lens: P/N 344-89924-40
 $\times 10$ objective lens: P/N 344-89941-40
 $\times 40$ objective lens with ultra-long operating distance: P/N 344-89300-41

40x objective lens with ultra-long operating distance. Improves contrast in the field-of-view.

Windbreak

P/N 347-27010-01

This case minimizes the influence of air disturbances, such as due to DUH tester exposure to air flow or sound.
 W700 x D650 x H750 (mm)

Windbreak (Large type)

P/N 347-27010-02

In the case that Active Vibration-Absorbing Bench is used this is selected.
 W700 x D650 x H900 (mm)

Vickers Hardness Standard Block

P/N 340-06619-07

Used for measuring hardness with the 700HMMV micro Vickers. Used as a rough guide for Vickers hardness measurement.

BK7 (Glass Test Piece)

P/N 339-89207-14

Used to obtain the correction factors required for the indenter when measuring the elastic modulus.

Triangular Pyramid Indenter with 100° Tip Angle

P/N 340-47011

This indenter, with a tip angle of 100°, has a smaller tip radius and makes smaller indentations than an indenter with a tip angle of 115°. Used for testing small-size specimens.

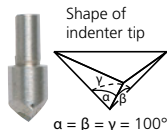

Measurement Kit for Vickers Hardness

P/N 347-24449-01

(Contents: Vickers Indenter 1 pc, Inspection Report 1 pc)

The verification in accordance with standard (ISO 6507-2) is done at the factory. Factory verified for compliance with Vickers hardness test standards.

Please order simultaneously with the DUH.

Measurement Kit for Knoop Hardness

P/N 347-24449-11

(Contents: Knoop Indenter 1 pc, Inspection Report 1 pc)

The verification in accordance with standard (ISO 4545-2) is done at the factory. Factory verified for compliance with Knoop hardness test standards.

Please order simultaneously with the DUH.

Desk-Type Vibration Absorbing Bench

P/N 344-04193-06

This bench with desk-type coil springs is recommended if the DUH-211/211S tester is used in areas that are subject to strong vibrations.

Active Vibration-Absorbing Bench

P/N 344-04211-11: AC 120 V

P/N 344-04211-12: AC 230 V

This bench is used together with a special mount and performs active vibration absorption over a wide range, from 0.7 Hz to 100 Hz.

Slender Specimen Holder

P/N 344-82943-40

This attachment is used to firmly hold thin specimens with an outer diameter of 0.15 mm to 1.6 mm, such as sewing machine needles, watch shafts, thin-shaped medical equipment, wires, sintered wires, and nonferrous wires.

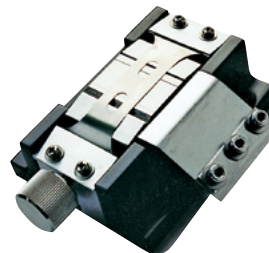

Disk-Type Vacuum Suction Unit

P/N 344-86201-42

Used for 5", 6", and 8" wafers. (Air supply for suction must be separately prepared.)

Micrometer Head (Digital Display)

P/N 347-25447-12 (2 unit)

Used to digitally display the amount of stage movement (up to a maximum of 25 mm) in the front/back or left/right directions in 1 μm increments. (Photo shows this head attached to a stage.)



Rotation Stage

P/N 344-82857-01

This stage has a diameter of 125 mm and can rotate in the range $\pm 5^\circ$.

Objective Micrometer

P/N 046-60201-02

Used to adjust the microscope's magnification factor. Marked with scale graduations at 10 μm intervals.

Installation Precautions Consider the following points when deciding on the installation location of the tester.

1. To minimize vibration:

- 1) Install the tester in a location where floor vibration is minimal. Normally, place the tester on a vibration-absorbing bench.
- 2) Do not install the tester in a location where people frequently walk by.
- 3) Do not install the tester near equipment that generates vibrations.
- 4) If possible, install the tester on the first floor of a building.
- 5) Install the tester as far away as possible from streets, roads and railway tracks.
- 6) Do not perform testing if vibration-generating equipment (e.g., a crane) is being used nearby.

2. To minimize air drafts and sounds:

- 1) Do not install the tester in locations that are directly or indirectly subject to streams of air from air-conditioning equipment.
- 2) Use a windbreak during testing.
- 3) Do not open or close nearby doors during testing.
- 4) Do not install the tester near sound-generating equipment (e.g., telephones).

3. To ensure testing accuracy:

Be especially careful when performing the following types of tests:

- Tests involving test forces of 1 mN or less
- Tests involving the measurement of changes for indentation depths of 0.05 μm or less

In these cases, be sure to maintain the following conditions:

- Temperature: No fluctuations greater than $\pm 1^\circ\text{C}$.
- Vibration: Refer to specification table.

Example of Dynamic Ultra Micro Hardness Tester DUH-211/210 Series Systems



Electric X-Y Stage System

P/N 347-24625-41

- Stroke X-axis, Y-axis ± 25 mm
(There is the function that the slides 50 mm toward the X-axis. All stroke of X-axis are 100 mm)
- Resolution 0.001 mm
- Drive method Ball screw actuated by stepping motor

* Compatible to electric Z system.
* The measuring kit is optional.

Related Products



Micro Compression Testing Machine MCT Series

This machine is used to measure the compressive strength of single particles (of diameter 1 μm or greater). The compressive strength of ceramics, plastics, pigments, food products, and pharmaceuticals can be measured at a particulate matter stage, providing data that is closely related to the final application of these substances.

- Loading Method Electromagnetic force
9.807 mN to 1.961 N or
9.807 mN to 4.903 N
- Indenter Diamond, cone-shaped,
50- μm diameter
- Displacement Measurement Differential transformer
0 μm to 10 μm or
0 μm to 100 μm
- Optical Monitor Equipped with $\times 500$
microscope



Micro Hardness Tester HMV-G31 Series

This type of hardness tester automatically measures length using a built-in CCD camera. The automatic measurement function provides easy and worry-free measurements without human error. The innovative G-frame provides a broad work area, dramatically improves operability, and easily accommodates long samples or other samples with a large area.

The automatic lens switching function automatically switches to the magnification appropriate for the given indentation size, which means anyone can operate the system accurately.

- Test Force Range 98.07 mN to 19.61 N
(Optionally from
9.807 mN)
- Indentation Measurement Time Approx. 0.3 sec.
- Equipped with revolving electric turret (HMV-G31T)



Fully Automatic Micro Hardness Tester HMV-G31-FA Series

By including an automatic measurement function, an electric XYZ stage function, and an auto-focus function to a micro Vickers hardness tester used for evaluating the hardness of paint or plating coatings or surface-hardened layers, this automatic hardness tester is able to perform a continuous series of highly precise measurements automatically.

- Test Force Range 98.07 mN to 19.61 N
(Optionally from
9.807 mN)
- Electric XY Stage Stroke: ± 25 mm
Resolution: 0.001 mm
- Electric Z Stage Stroke: 40 mm
Resolution: 0.001 mm

Windows is a registered trademark of Microsoft Corporation in the US and other countries.



Shimadzu Corporation
www.shimadzu.com/an/

For Research Use Only. Not for use in diagnostic procedures.

This publication may contain references to products that are not available in your country. Please contact us to check the availability of these products in your country.
Company names, products/service names and logos used in this publication are trademarks and trade names of Shimadzu Corporation, its subsidiaries or its affiliates, whether or not they are used with trademark symbol "TM" or "®".
Third-party trademarks and trade names may be used in this publication to refer to either the entities or their products/services, whether or not they are used with trademark symbol "TM" or "®".
Shimadzu disclaims any proprietary interest in trademarks and trade names other than its own.

The contents of this publication are provided to you "as is" without warranty of any kind, and are subject to change without notice. Shimadzu does not assume any responsibility or liability for any damage, whether direct or indirect, relating to the use of this publication.