

# Precision Hydrogen 1200cc (All Models)

## Installation Guide

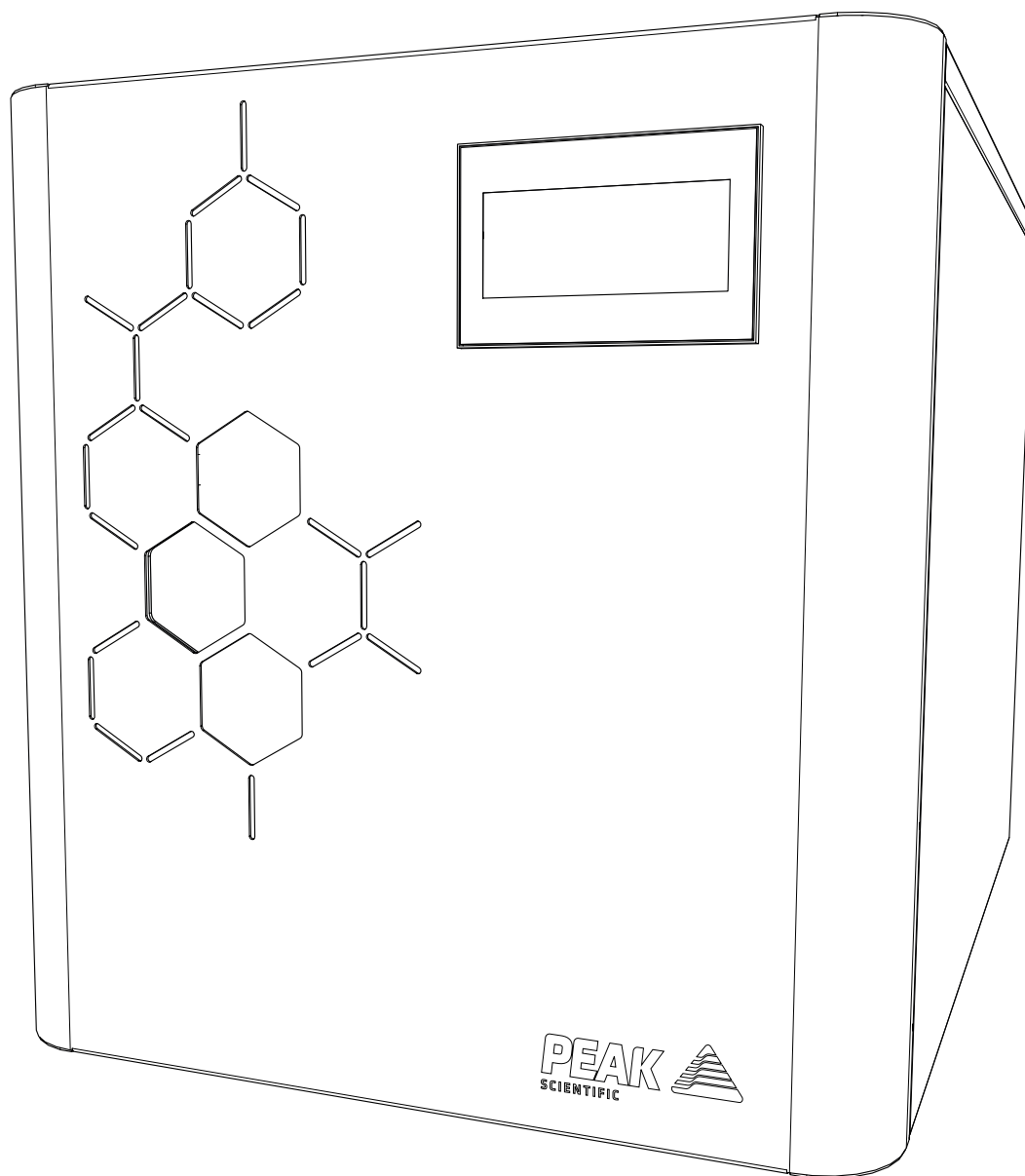

# Change History

Rev	Comment	Name	Date
1	Initial Release	Liam Couttie	09/02/2018
2	Transit Plugs Added	Liam Couttie	22/03/2018
3	Trace Model Information Added	Liam Couttie	23/07/2018
4	Warranty Information Update	Liam Couttie	26/11/2018
5	Layout Update for Printing	Liam Couttie	06/01/2020

## How to use this Manual

This installation guide is intended to be used as a step by step, quick start guide, to facilitate installation and configuration.

**Please visit [www.peakscientific.com/downloads](http://www.peakscientific.com/downloads) to download the full User Manual for your gas generator.**



Thank you for selecting Peak Scientific to meet your Gas Generation needs, and should you require any further assistance or support please do not hesitate to contact Peak Scientific or Peak Partner from which you purchased your Generator.

# Safety Notices

Peak Scientific Instruments cannot anticipate every possible circumstance which may represent a potential hazard. The warnings detailed within this document detail the most known potential hazards, but by definition cannot be all inclusive. If the user employs an operating procedure, item of equipment or a method of working which is not specifically recommended by Peak Scientific, the user must ensure that the equipment will not be damaged or become hazardous to persons or property.

## Symbols

This document uses the following symbols to highlight specific areas important to the safe and proper use of the Generator

 WARNING	A WARNING notice denotes a hazard. It calls attention to an operating procedure, process or similar, which if not correctly performed or adhered to, could cause personal injury or in the worst case death. Do not proceed beyond a WARNING notice until the indicated conditions are fully understood or met.
 CAUTION	A CAUTION notice denotes a hazard. It calls attention to an operating procedure, process or similar, which if not correctly performed or adhered to, could cause damage to the Generator or the Application. Do not proceed beyond a CAUTION notice until the indicated conditions are fully understood or met.
	Caution, risk of electric shock. Ensure power to the Generator has been removed before proceeding.

## Safety Notice to Users



These instructions must be read thoroughly and understood before installation and operation of your Peak Precision Hydrogen Generator. Use of the Generator in a manner not specified by Peak Scientific MAY impair the SAFETY provided by the equipment.



When handling, operating or carrying out any maintenance, personnel must employ safe engineering practices and observe all relevant local health and safety requirements and regulations. The attention of UK users is drawn to the Health and Safety at Work Act 1974, and the Institute of Electrical Engineers regulations.



If the equipment is used in a manner not specified by the manufacturer, the protection provided by the equipment may be impaired.

# Fittings Kit

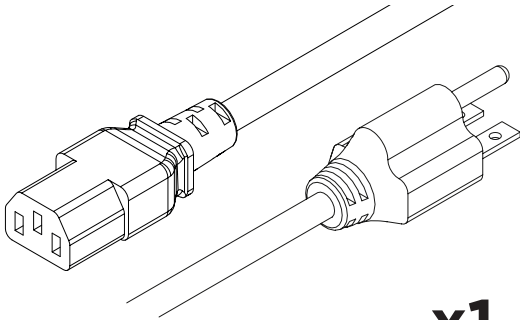

**x1**  
US Mains Cable C13 6-15 04-1029\*

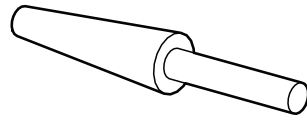

**x2**  
Transit Plug 3301437

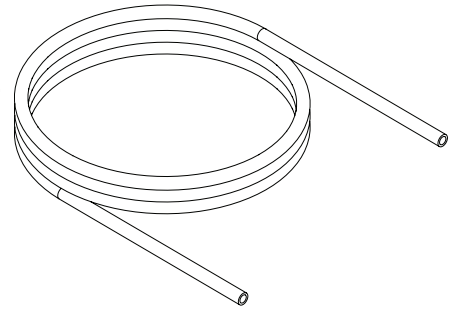

**x1m**  
Tygon Tubing 05-3131

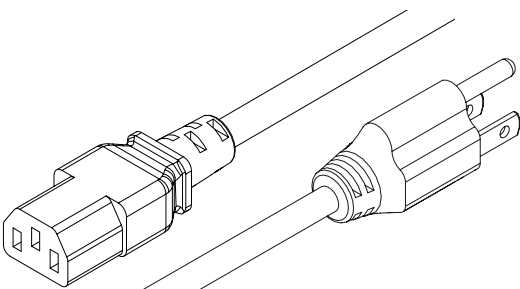

**x1**  
US Mains Cable C13 5-15 04-1039\*

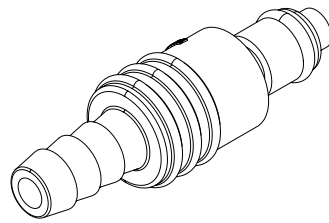

**x1\*\***  
Barbed Fitting 05-7029

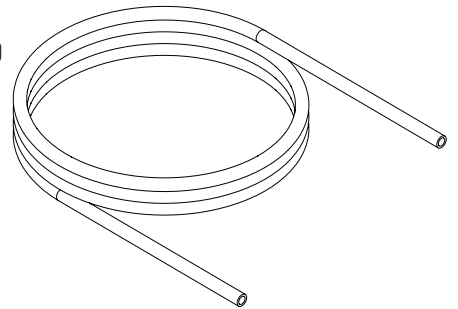

**x1m**  
Teflon Tubing 00-4411

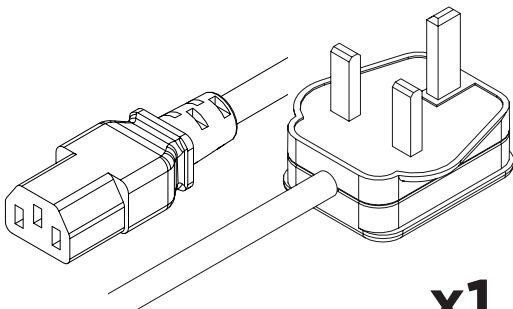

**x1**  
UK Mains Cable C13 04-1028

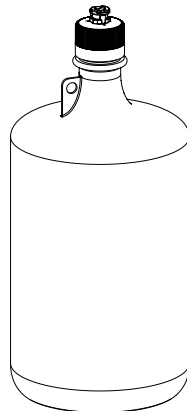

**x1**  
\*\*\*4L Water Bottle 10-9016

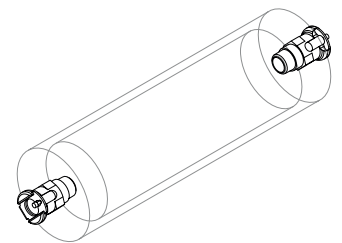

**x1**  
Deioniser Column 05-7062

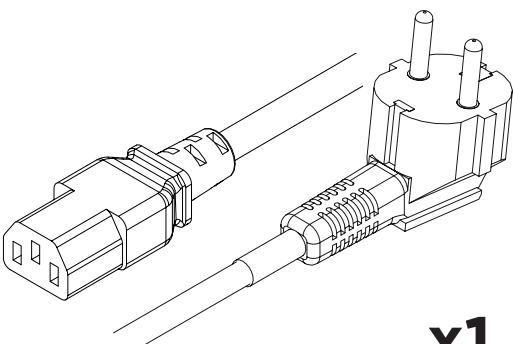

**x1**  
EU Mains Cable C13 04-1038

\* See Section 14, Regarding Connection Type  
 \*\* Additional Barbed Fitting with 4L Water Bottle  
 \*\*\* Optional Extra

1.

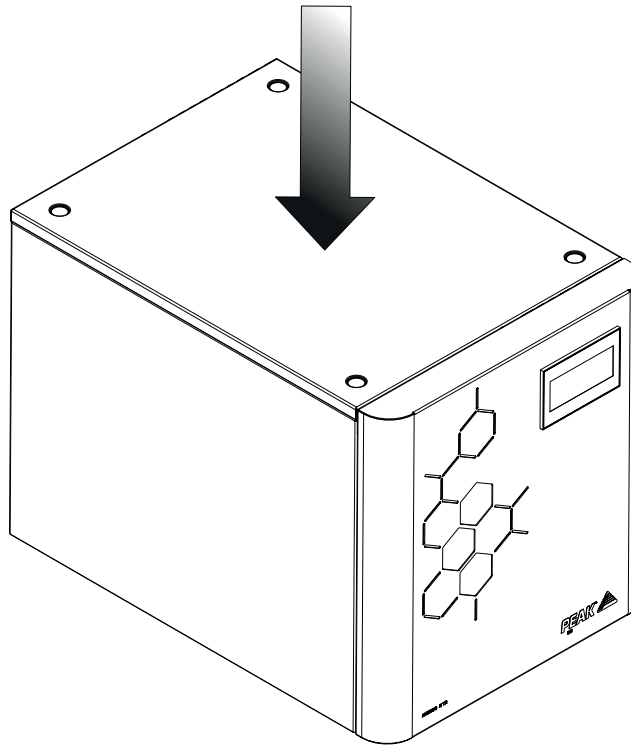

Unpack the generator from the shipping crate and position on a flat surface, in desired area.

**WARNING** the weight of the unit constitutes a two man lift. Safe lifting practices are advised.

2.

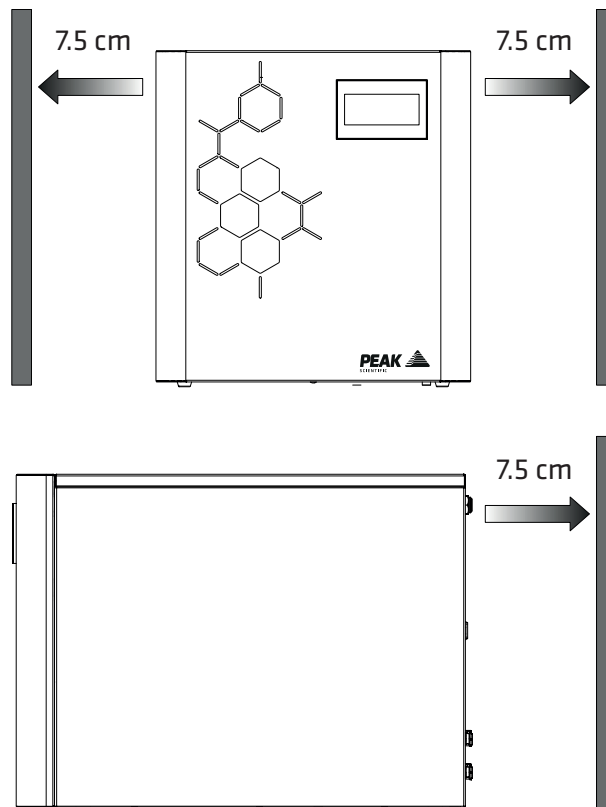

Ensure that there is at least 7.5 cm of space to the sides and rear of the generator.

3.

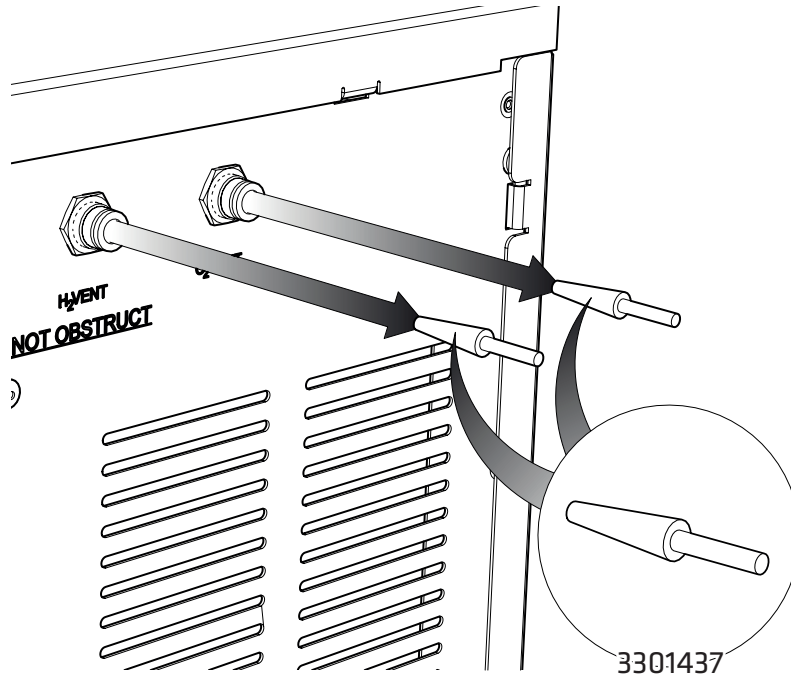

Remove the **two Transit Plugs** from the **H<sub>2</sub>** and **O<sub>2</sub> Vent** ports located at the rear of the generator.

4.

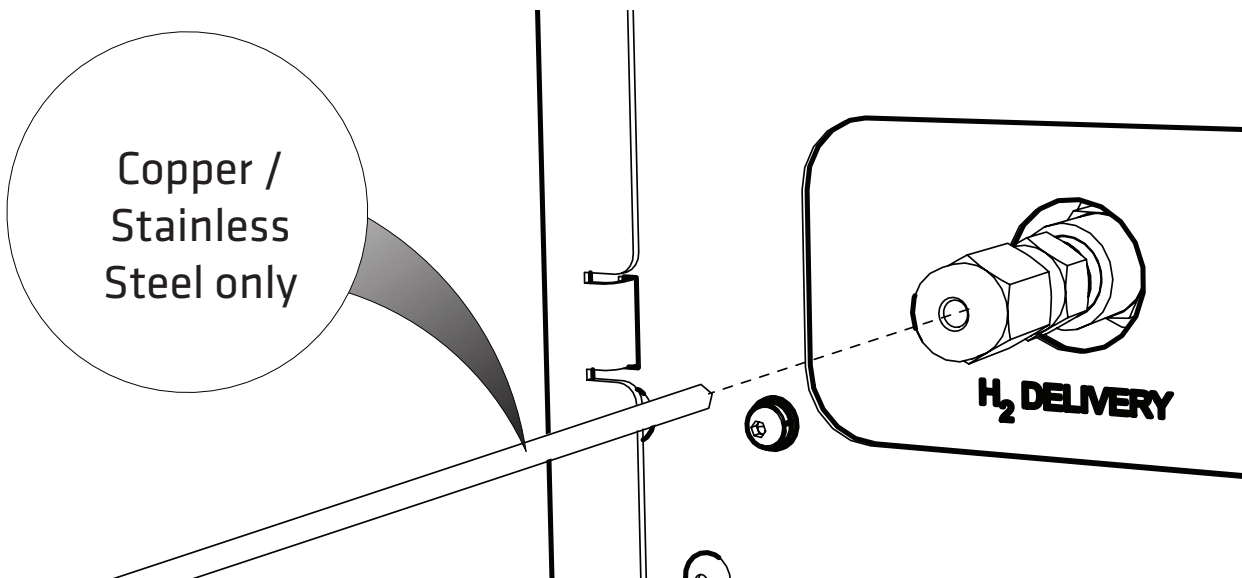

Connect tubing, to the **H<sub>2</sub> Delivery** port at the rear of the generator. Tubing must be clean, laboratory grade, copper or stainless steel only.

5.

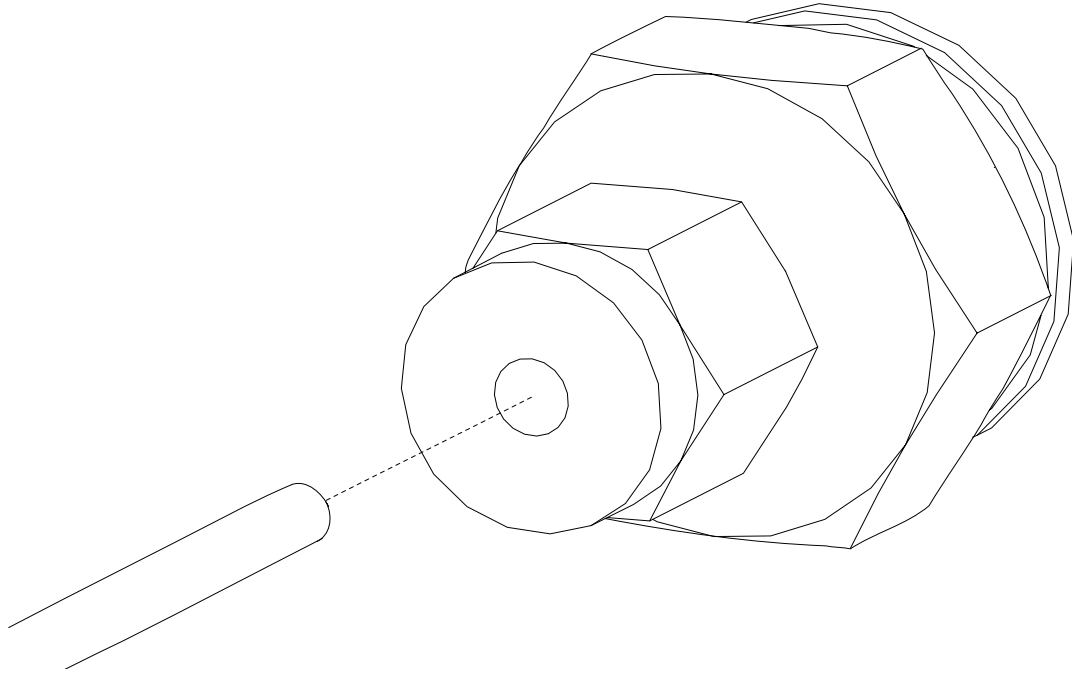

Connect the other end of the tubing to the **Application**.

6.

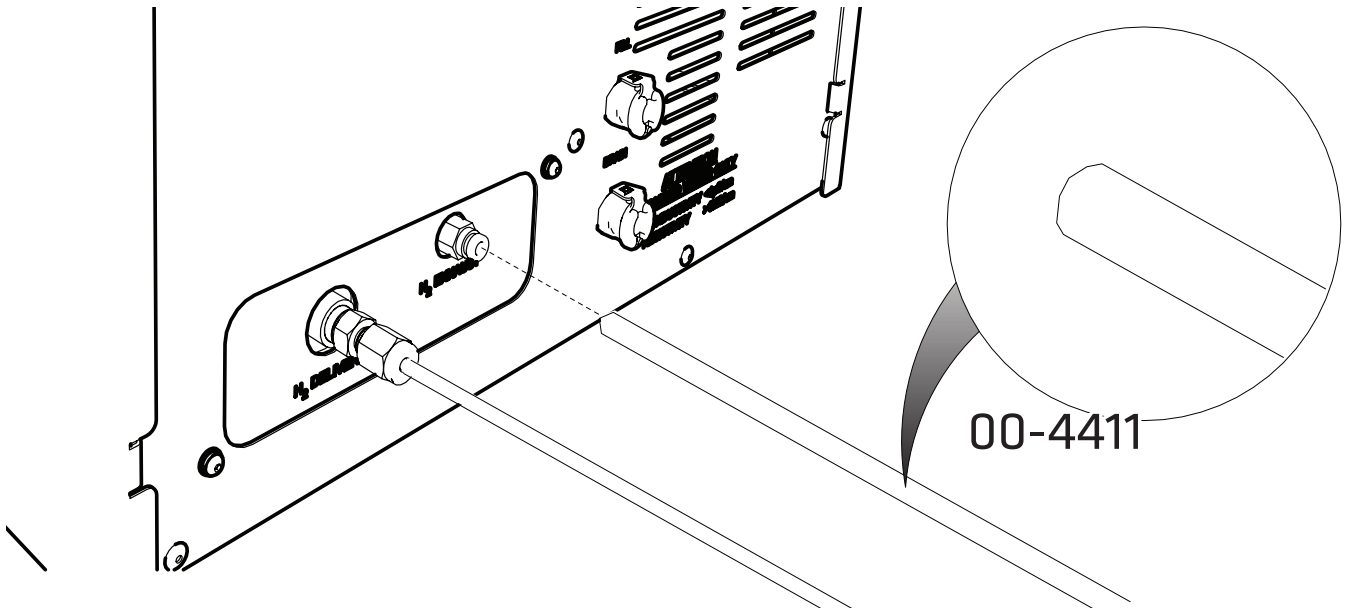

Fit appropriate tubing to **H2 Exhaust** output.  
Flow from the exhaust is minimal during operation.

7.

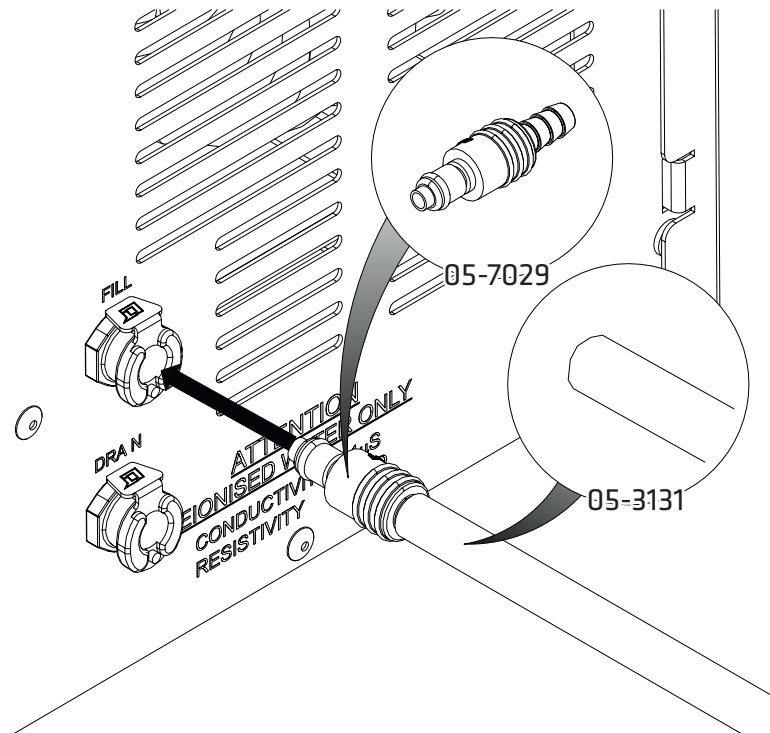

The **Tygon Tubing** and **Barbed Fitting** supplied in the generator fittings kit should be connected to the **Fill** port at the rear of the generator.

8.

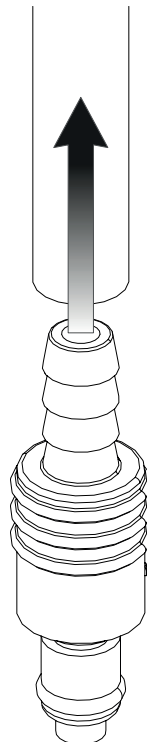

If using a **Peak Water Bottle**, connect the remaining **Barbed Fitting**, from the fittings kit, to the other end of the **Tygon Tubing**.

If using an alternative water bottle, connect the **Tygon Tubing** to your **High Grade De-Ionised Water Supply (<math><1 \mu\text{S}/\text{cm}</math>)** and **continue from step 13**.



9.

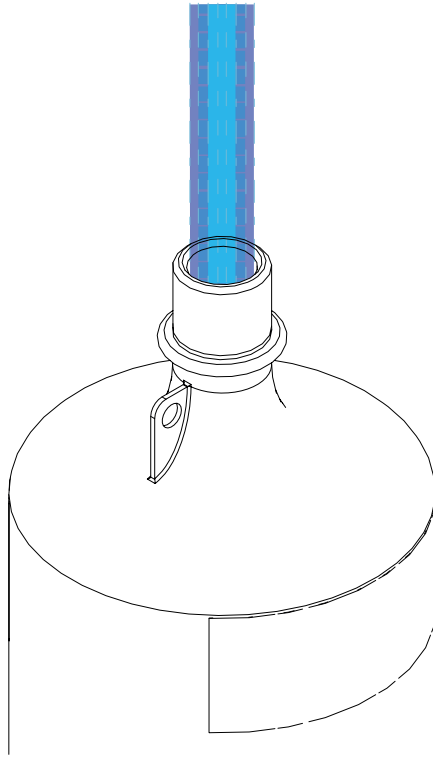

Remove the lid from the bottle by unscrewing anticlockwise and rinse the bottle with **High Grade De-Ionised Water (<math><1 \mu\text{S}/\text{cm}</math>).**

10.

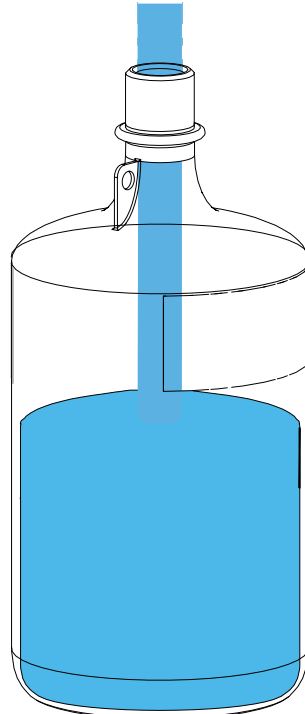

After the bottle has been rinsed it should be filled with **High Grade De-Ionised Water (<math><1 \mu\text{S}/\text{cm}</math>).**

11.

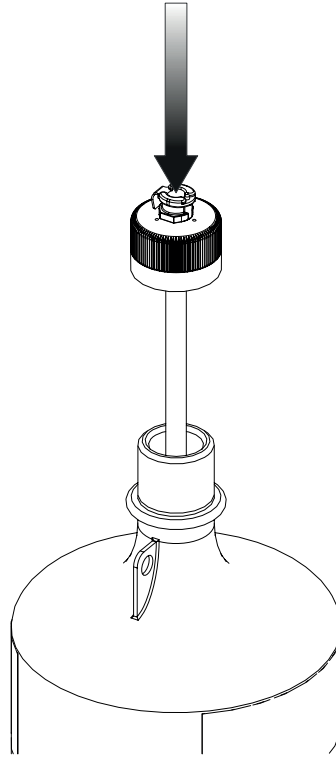

Once the bottle has been **filled**, replace the **lid**.

12.

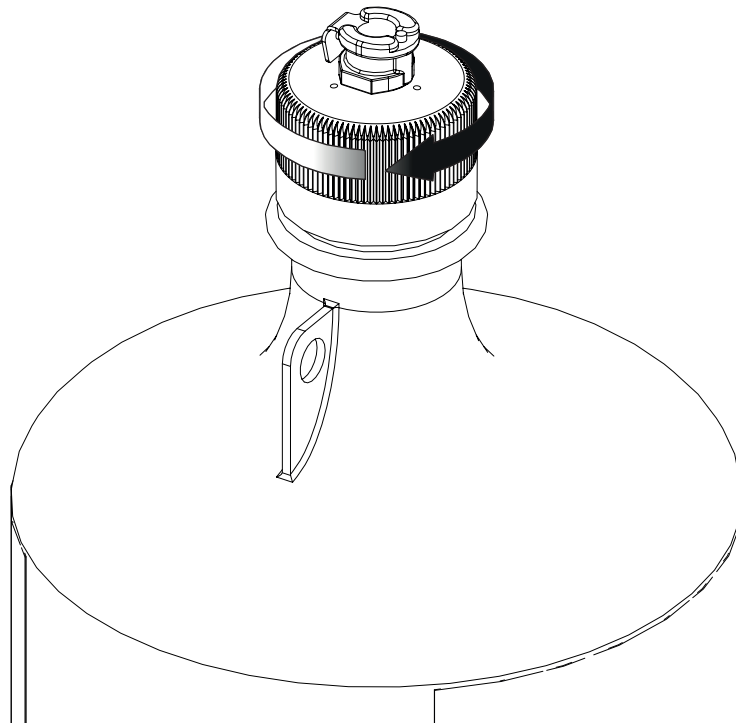

Ensure the **lid** is securely fastened by turning it **clockwise**, and that the air-holes on the lid are **free from obstruction**.

13.

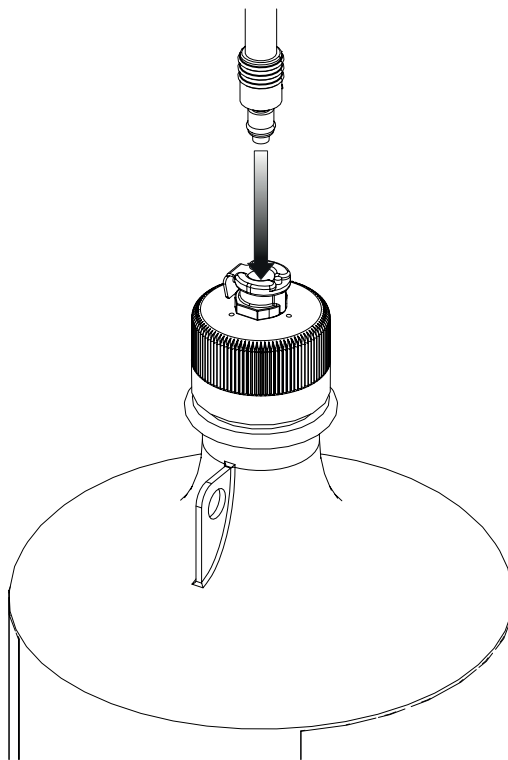

Connect the **Barbed Fitting** on the end of the **Tygon Tubing** to the connection on the top of the filled **Water Bottle**, ensuring there is a secure connection.

14.

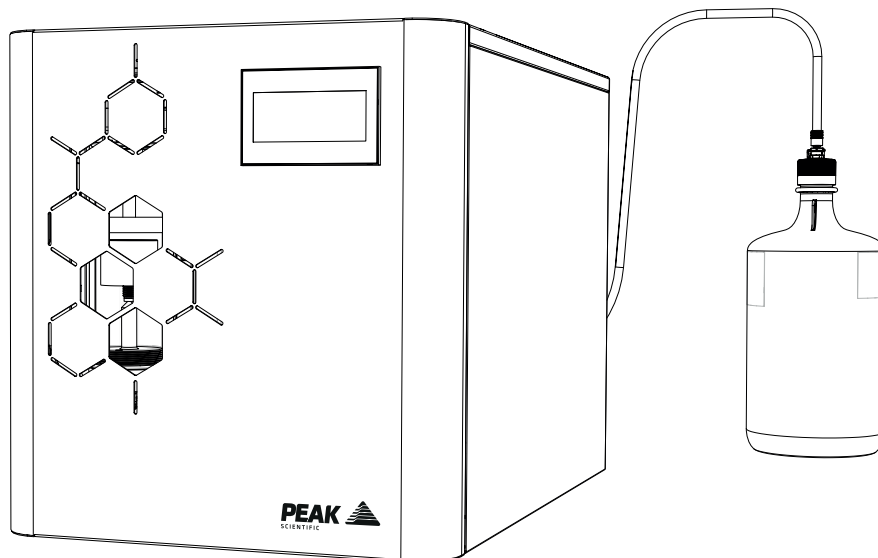

Make sure the **Water Bottle** is on a level surface at the **same height as the generator**.

15.

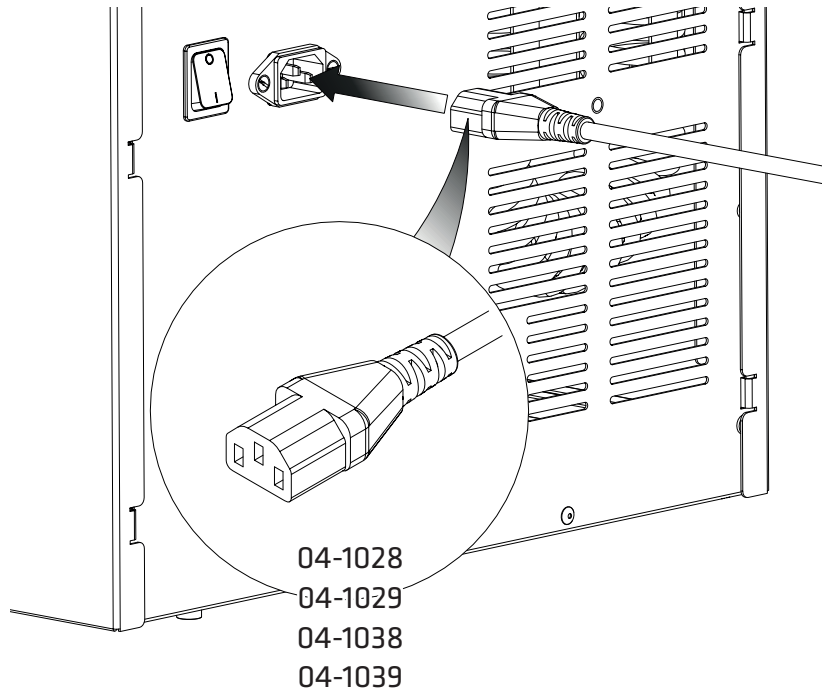

Select the appropriate **mains cable** from the fittings kit and insert the IEC 60320/C13 plug into the **mains input** at the rear of the generator

16.

UK

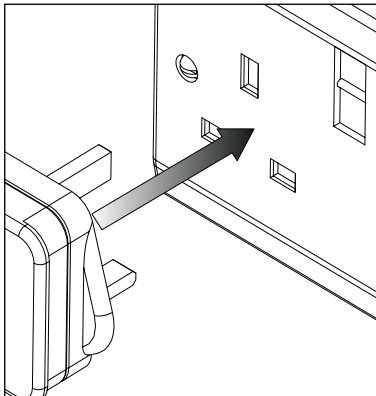

EU

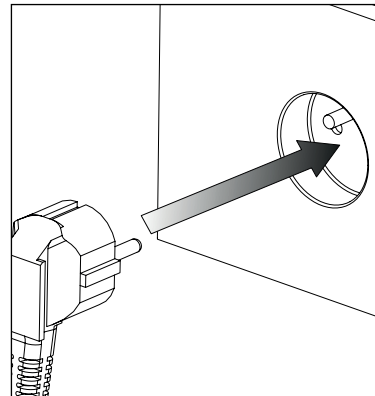

US  
110V

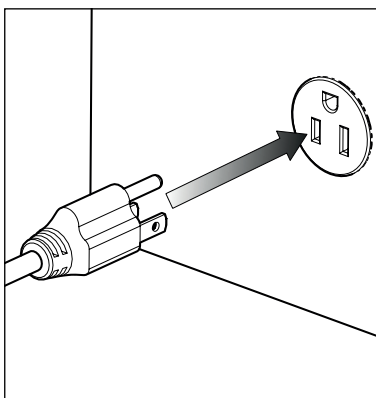

US  
230V

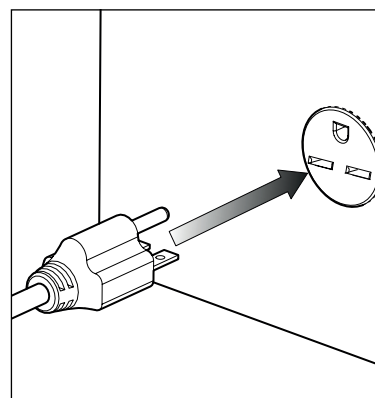

100-230VAC 50/60Hz

Plug the **mains cable** into an appropriate **100-230VAC 50/60Hz single phase power supply**.

**CAUTION** ensure the correct cable has been selected for your electrical supply

17.

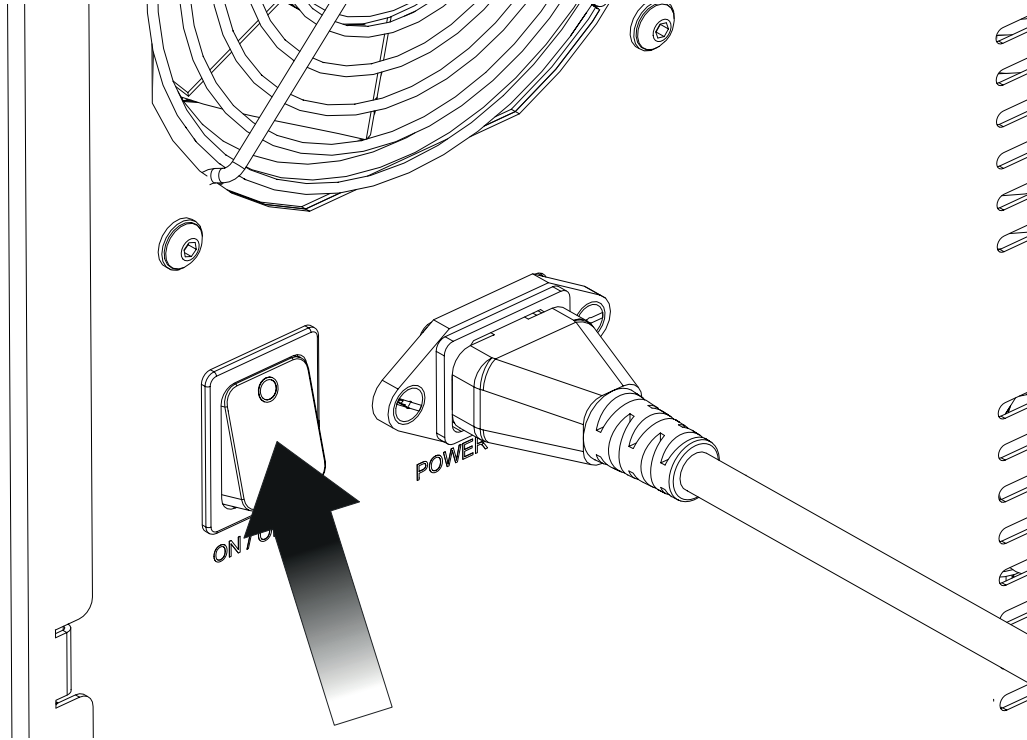

Turn the generator on, using the **switch** on the back of the unit.

18.

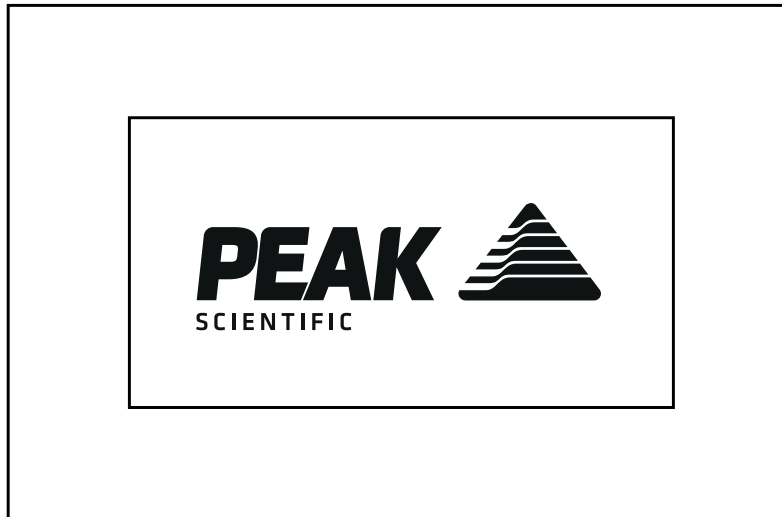

The touch HMI screen will **illuminate** and the **start screen** will be displayed.

19.

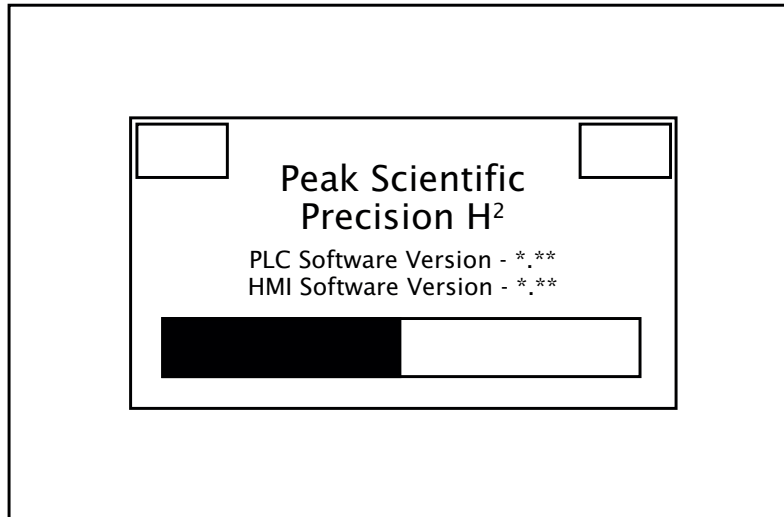

The system will now run **diagnostics** and a **leak detection** test.

**Note: In the unlikely event that diagnostics are unsuccessful, an alarm will sound and a red failure screen will be displayed, complete with a mute button. The user is prompted at this point to contact their Peak service provider.**

20.

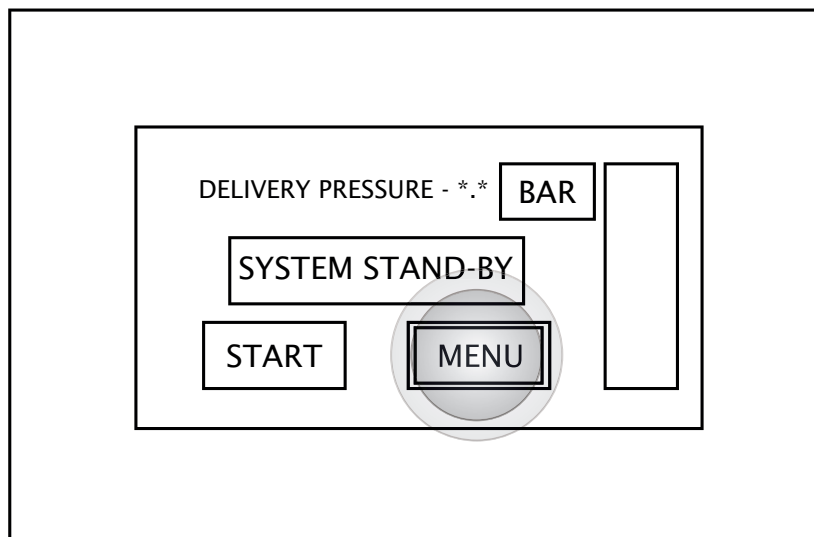

Upon completion of the diagnostic checks, the home screen will be displayed. The user should now **select MENU**.

21.

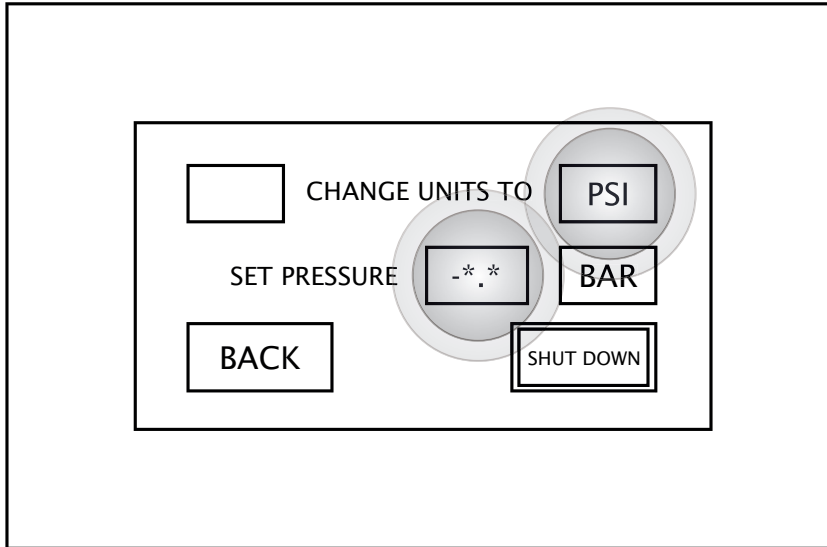

The desired unit of measure and pressure should now be selected, by pressing the **unit** or **pressure displayed**.

22.

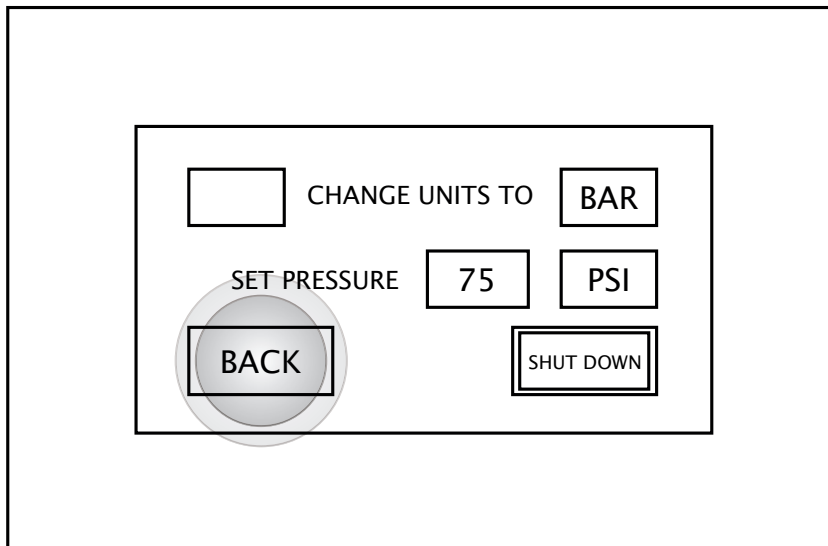

Once the desired unit of measure and pressure have been selected, pressing **BACK** will return the user to the home screen.

23.

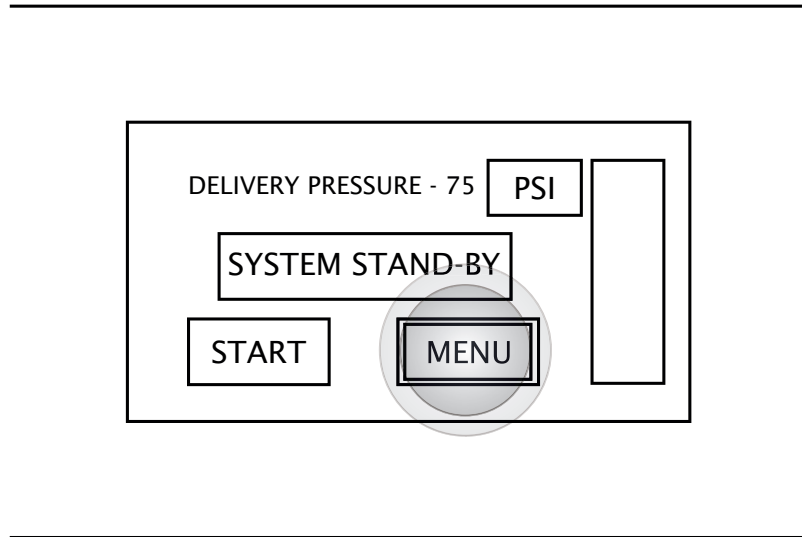

Pressing **START** will start the supply to the application. The unit may take a few minutes to adjust to the desired pressure.

24.

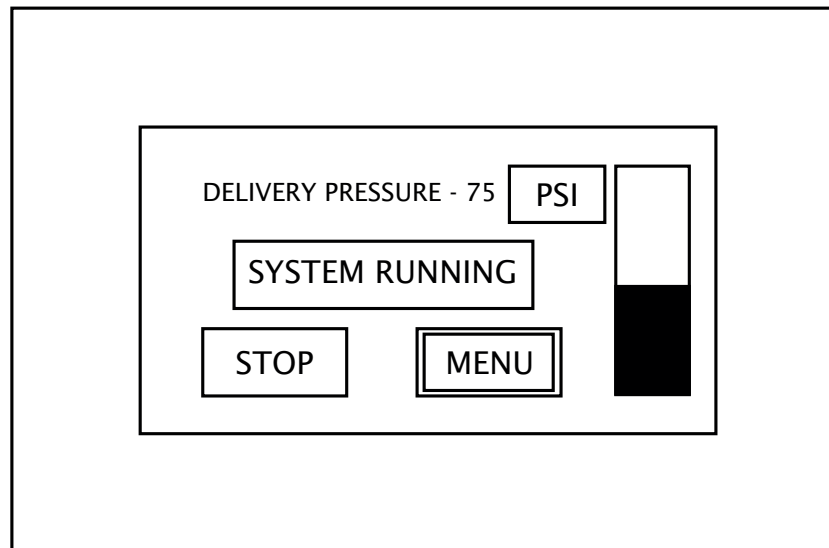

The unit will now maintain the desired pressure, while the application is supplied.



25.

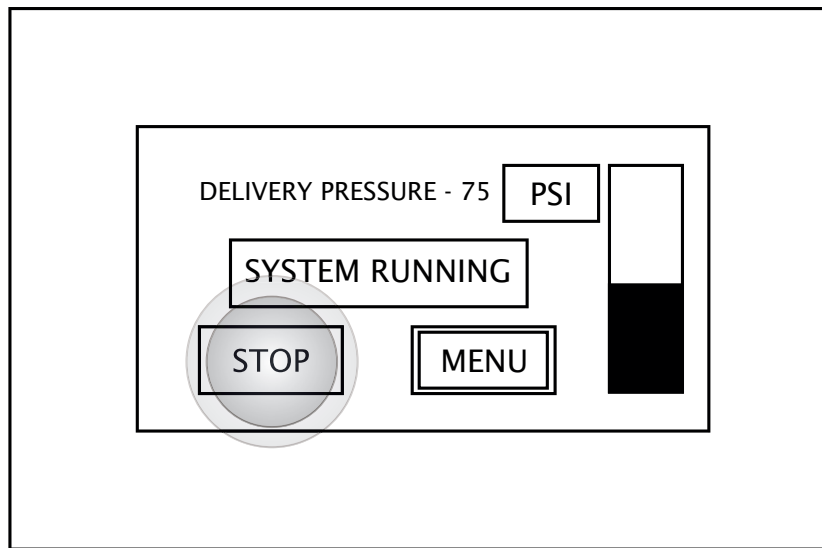

The system can be stopped at any time by pressing **STOP**. This will return the generator to Standby mode.

26.

**Standard**

**Trace**

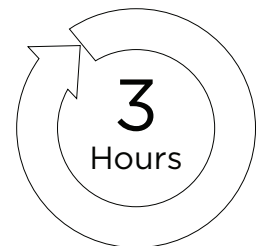
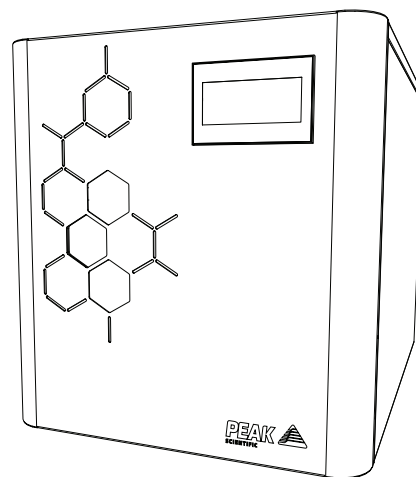
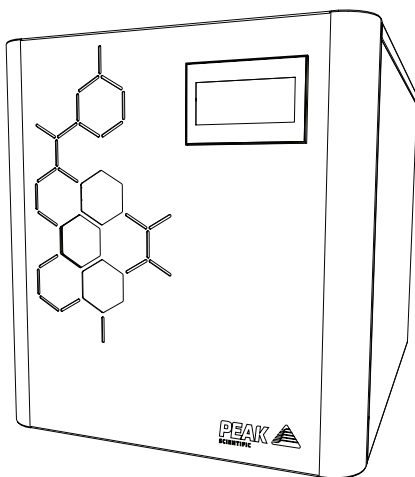

It is recommended that the **Standard** unit is left to run for **24 hours**, and the **Trace** unit is left to run for **3 hours** before utilisation.

27.

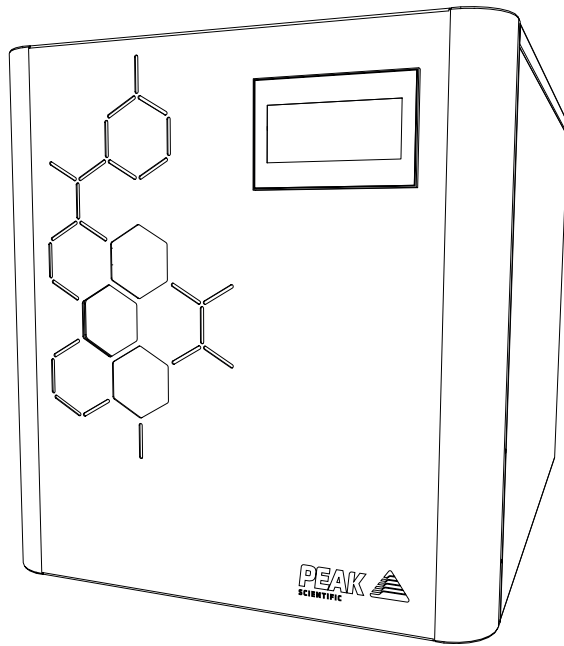

# CONGRATULATIONS

Your **PEAK SCIENTIFIC** gas generator is now fully installed, operational and ready to supply gas on demand to your instrument.

## General Notes

Ensure water supply bottle is not located above the height of the generator, and that the supply is not pressurised.

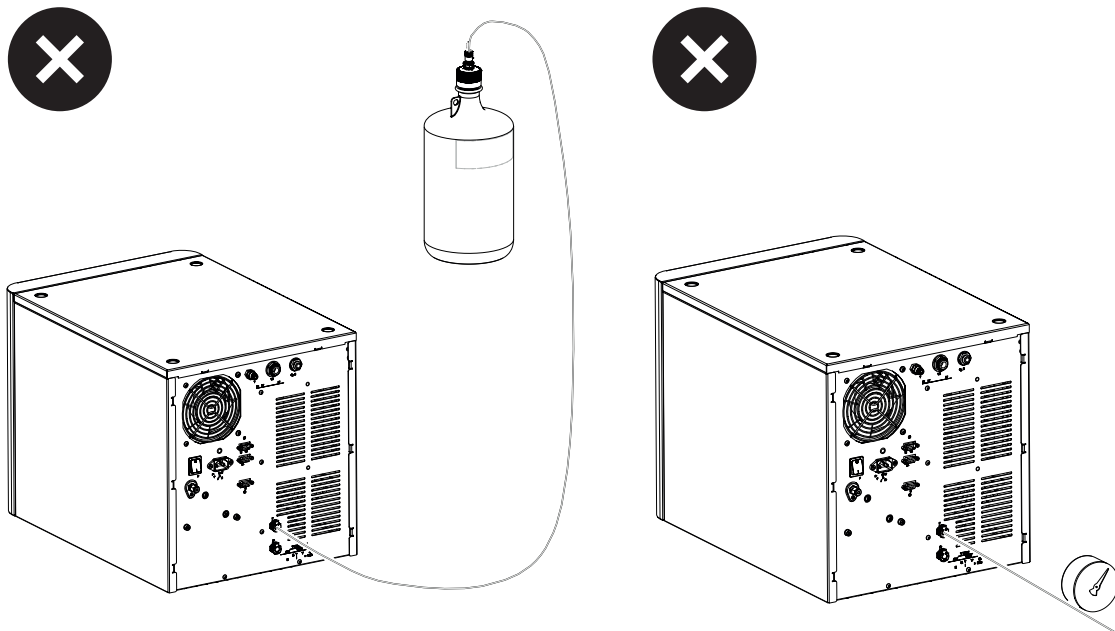

Electrical requirements are 100-230V rms nominal. However, running continuously at voltages outwith this is not recommended. Extended periods at extremes can have a detrimental effect on the operation and life of the Generator.

Ensure that all pipework between generator and equipment is checked for leaks.

Please familiarise yourself with the full **User Manual** available at [www.peakscientific.com/downloads](http://www.peakscientific.com/downloads) This includes all other technical specifications, operating instructions, service requirements, contact details and trouble shooting.

It is very important to register your generator with PEAK SCIENTIFIC. This will initiate your warranty entitlement. Please use the form on the next page to register your generator. You will need the generators serial number which can be found on the serial label on the rear of the generator.

# Go Online or Complete and Return

We know that registering any of your recently purchased products is not the first thing on your mind- but it is very important to both of us. Not all warranties are alike and Peak Scientific stand out against other gas suppliers as we offer a comprehensive on-site warranty. This means that in the very unlikely case that your gas generator develops a fault we have rapid support teams on-hand throughout the globe who are able to come to your lab and get you back up and running in no time.

Register for your **comprehensive 3 year on-site warranty** with ease online at [www.peakscientific.com/protected](http://www.peakscientific.com/protected).

Alternatively, you can send the completed form to Peak Scientific by post or email at [warranty@peakscientific.com](mailto:warranty@peakscientific.com).

**Go Online or Complete and Return**

You can register for your **FREE 12 month Warranty** with ease online at [www.peakscientific.com/protected](http://www.peakscientific.com/protected).

Alternatively, you can send the completed form to Peak Scientific by post or email at [warranty@peakscientific.com](mailto:warranty@peakscientific.com).

Product Warranty Registration			
Contact name			
Email address			
Company			
Address			
City/town			
Postcode			
Country			
Telephone			
Generator serial #			
Model type			
Installation date			
Do you still use an alternative gas solution i.e. cylinders or bulk liquid?	Yes	No	
What gas requirements do you have in your lab?	Hydrogen	Nitrogen	Zero Air

**Extend your cover with**

Peak Scientific offer comprehensive gas generator after sales support packages. Peak [Protected] aftercare support can guarantee an on-site response within 72 hours\*, genuine parts from our ISO9001 approved factory and a 95% first-time fix rate. See our enclosed Peak [Protected] leaflet for further information.

**Important!**

You have 1 month to register your Peak Scientific product from the date of installation. Once registered the warranty will be honoured for a period of 12 months. If you wish to defer the installation of your generator, you must notify Peak Scientific immediately by emailing [warranty@peakscientific.com](mailto:warranty@peakscientific.com). For generators that remain unregistered after 1 month from the shipment date, the warranty will be considered active from the date of factory dispatch.

\* Complete Plan only



## Important!

You have **1 month to register** your Peak Scientific product from the date of installation. Once registered the warranty will be honoured for a period of 3 years. If you wish to defer the installation of your generator, you must notify Peak Scientific immediately by emailing **warranty@peakscientific.com** For generators that remain unregistered after 1 month from the shipment date, the warranty will be considered active from the date of factory dispatch.







Please visit [www.peakscientific.com/downloads](http://www.peakscientific.com/downloads) to download the full User Manual for your gas generator.

## [**PEAK Protected**]<sup>™</sup>

Peak Scientific has highly trained, fully certified Field Service Engineers located in over 20 countries across every continent around the world. This allows us to provide an industry-leading rapid response service to our customers. With [**Peak Protected**], your laboratory's productivity becomes our top priority.

To discuss Peak Protected generator cover and payment options speak to your local Peak Representative or for further information contact: [protected@peakscientific.com](mailto:protected@peakscientific.com)

### **Peak Scientific**

Fountain Crescent  
Inchinnan Business Park  
Inchinnan  
PA4 9RE  
Scotland, UK  
**Tel:** +44 141 812 8100  
**Fax:** +44 141 812 8200

For further information on any of our generator products please contact [marketing@peakscientific.com](mailto:marketing@peakscientific.com)

