



Agilent G4406A Flame Ionization EPR Detector

For the Agilent 7820A Gas Chromatograph

Installation Instructions

CAUTION

This guide explains how to install the Agilent G4406A Flame Ionization EPR Detector.

Before installing the Agilent G4406A Flame Ionization EPR Detector, update the GC firmware to revision **A.01.18** or higher and the GC driver to **B.01.01** or higher. See “[Update the GC firmware revision](#)” and “[Update the GC driver version](#)” on page 4.

Compatibility Information

The Agilent 7820A GC supports both EPR (electronic pneumatics regulation) and EPC (electronic pneumatics control) inlets and detectors. It is possible to use some EPR components along with some EPC components. [Table 1](#) specifies the allowable configurations.

Table 1 Allowable inlet and detector configurations

Configuration	Location	Inlet	Detector
All EPR	Front	EPR	EPR
	Back	EPR	EPR
All EPC	Front	EPC	EPC
	Back	EPC	EPC
EPC Inlets/EPR Detectors	Front	EPC	EPR
	Back	EPC	EPR



Parts Supplied

Table 2 Parts supplied

Description	Quantity	Part Number
FID Detector Module with EPR Manifold	1	G4331-63526
FID Board	1	G3431-61820
Nutwarmer cup	1	19234-60700
Nutwarmer insulation	3	19234-60715
SWG Cap, Series II	3	05890-40230
7820 FID Packed and Capillary ship kit		G4331-60640
FID flow measuring insert	1	
1/8 in FID/NPD packed column adapter	1	
1/4 in Ferrule Vespal	1	
Tube-fitting-nut 1/4 in DIA brass	1	
Driver, nut (for FID jet replacement)	1	
Tee, 0.12/0.12/0.13 in DIA brass	1	

Parts Identification

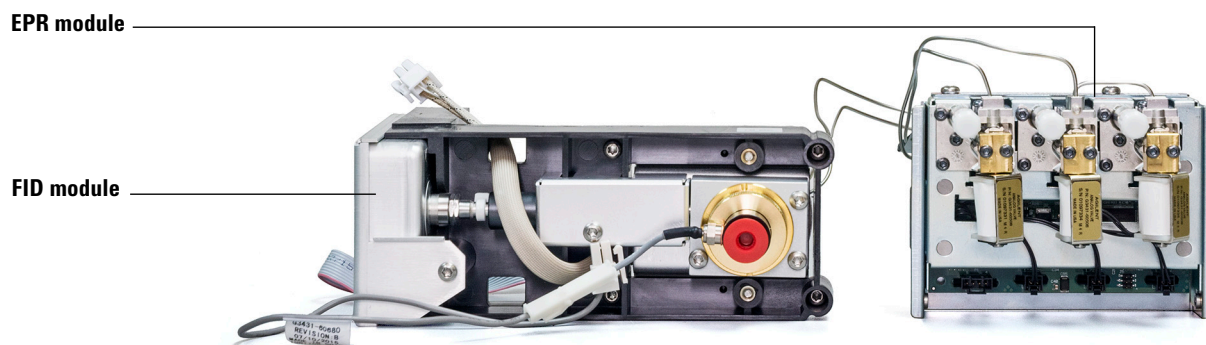

Figure 1 FID parts identification

Tools Required

- T-20 Torx driver
- Wrench
- Razor knife
- Flat-blade screwdriver
- Diagonal sheet metal cutter
- ESD wrist strap

Software Required

- Agilent 7820A GC Software Keypad with Data Analysis

Installation

This procedure explains how to install the flame ionization detector (FID) with EPR accessory on the Agilent 7820A Gas Chromatograph (GC).

WARNING

Refer to the Safety Manual that came with your Agilent 7820A Gas Chromatograph for hazards that may exist when maintaining your instrument.

Update the GC firmware revision

The Agilent G4406A Flame Ionization EPR Detector requires 7820A GC firmware revision A.01.18 or higher.

CAUTION

Before installing the Agilent G4406A Flame Ionization EPR Detector onto the GC, power on the GC, and update the firmware to revision A.01.18 or higher, if required.

To update the GC firmware revision:

- 1 Connect to the GC with the software keypad.
- 2 Click [**Status**][**Clear**]. The firmware version is displayed on the software keypad.

NOTE

The currently installed firmware version can also be checked by power cycling the GC. The firmware version is displayed after the GC successfully reboots.

- 3 If the GC firmware version is earlier than **A.01.18**, use the Agilent GC Firmware Update Tool to update the firmware. (To obtain the latest firmware revision, visit <http://www.agilent.com> and search for GC firmware update.)

Update the GC driver version

The Agilent G4406A Flame Ionization EPR Detector requires the use of GC Driver version **B.01.01 or higher**. Check the GC Driver version used in your Agilent data system, and update as needed.

NOTE

Customers who perform software qualification should review their SOPs, risk assessment, and other regulatory considerations to determine whether the instrument driver update requires a software requalification.

Agilent GC Drivers provide control of 7820 in the following Agilent data systems:

- G17xxFA GC/MS MassHunter Acquisition
- M84xxAA OpenLAB CDS
- M83xxAA OpenLAB CDS ChemStation Edition
- M82xxAA OpenLAB CDS EZChrom Edition
- G4691AA EZChrom Elite (3.3.2 SP2 or higher)
- M207xBA Multi-Technique ChemStation (B.04.03 SP2 or higher)

Prepare the GC

- 1 Connect to the GC with the software keypad.
- 2 Cool the inlets, detectors, and oven to room temperature.
- 3 Turn off the GC, and unplug the power cord.
- 4 Turn off all gas supplies.
- 5 Remove the detector cover as follows:
 - a Open the detector cover to its vertical position.
 - b Disengage the cover from the hinges, right side first.
 - c Remove the detector cover from the GC.
- 6 Remove the pneumatics cover as follows:
 - a Remove the screw on the side of the pneumatics cover.
 - b Loosen the two screws on the back of the pneumatics cover.
 - c Remove the pneumatics cover from the GC.
- 7 Remove the side panel as follows:
 - a Remove the screw on the back of the side panel.
 - b Remove the screw on the side of the side panel.
 - c Slide the toward the back of the GC.
 - d Tilt the top of the side panel out and lift to remove.
- 8 Remove top electronics cover as follows:
 - a Remove the screw on the side of the electronics cover.
 - b Remove the screw on the back of the electronics cover.
 - c Lift the cover off of the GC.
- 9 Put on an ESD wrist strap, and attach the ground to the GC sheet metal frame for electrostatic protection.

Prepare the detector mounting

- 1 Locate the position on the top of the GC for the detector. Remove the round metal cutout at this location using diagonal cutters. Make the cuts so that the metal nubs remain attached to the discarded metal circle.
(See [Figure 2](#).)

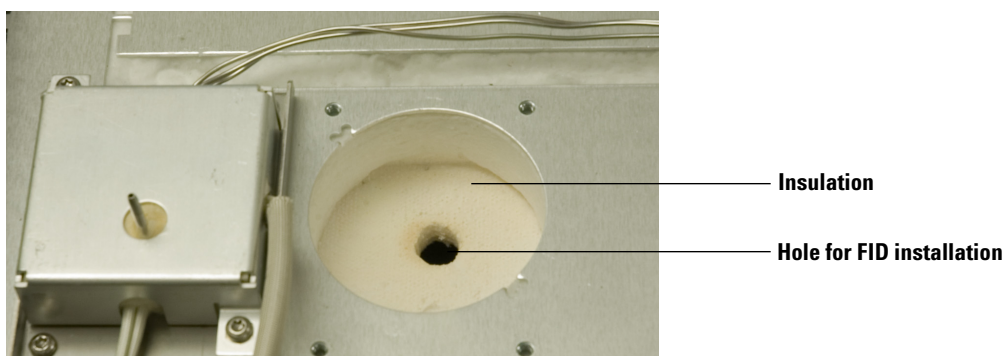

Figure 2 Prepared mounting hole for the FID

- 2 Remove and discard the circular insulation plug.
- 3 Using the flat-blade screwdriver, punch a hole (approximately $\frac{1}{4}$ inch ID) in the oven insulation.
- 4 Clean up any insulation that falls into the oven.

Install the detector

CAUTION

When handling the detector flow tubing, avoid bending the tubing at sharp angles.

- 1 Carefully uncoil the tubing between the detector body and its EPR module (see [Figure 1](#) on page 3). Lay the entire assembly on the oven top with the detector near its intended location and the EPR module near its associated location in the EPR module bays.
- 2 Before mounting the detector, connect the FID heater cable to the GC heater connector located in the right side of the GC directly adjacent to the detector cutout. (See [Figure 3](#).)

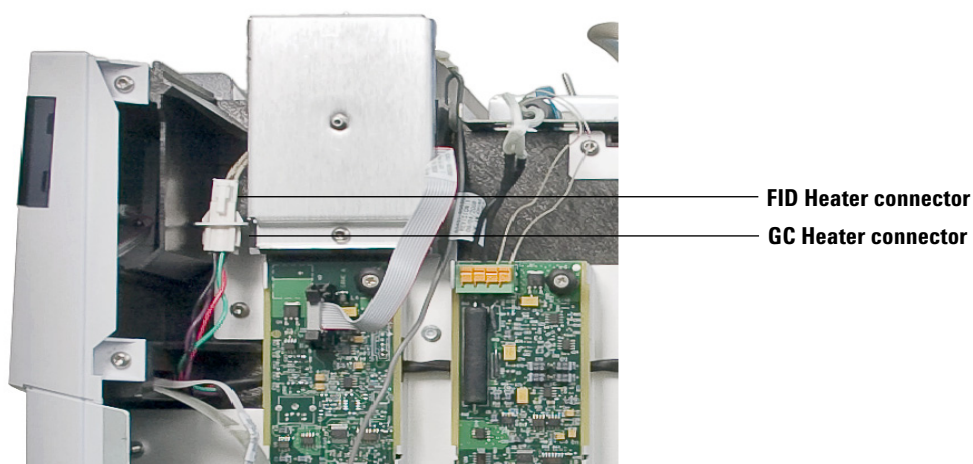

Figure 3 Connecting the FID heater cable

- 3 Insert the FID into the designated detector position so the column fitting extends through the hole in the insulation and into the oven. (See [Figure 4](#).)

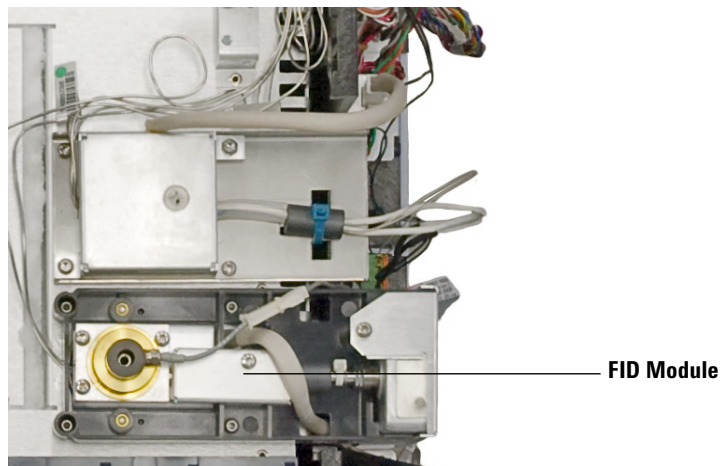

Figure 4 Installing the FID

- 4 Attach the detector to the instrument by tightening the four captive screws located around the detector opening.
- 5 Orient the tubing from the detector to the EPR module. (See [Figure 5](#).)

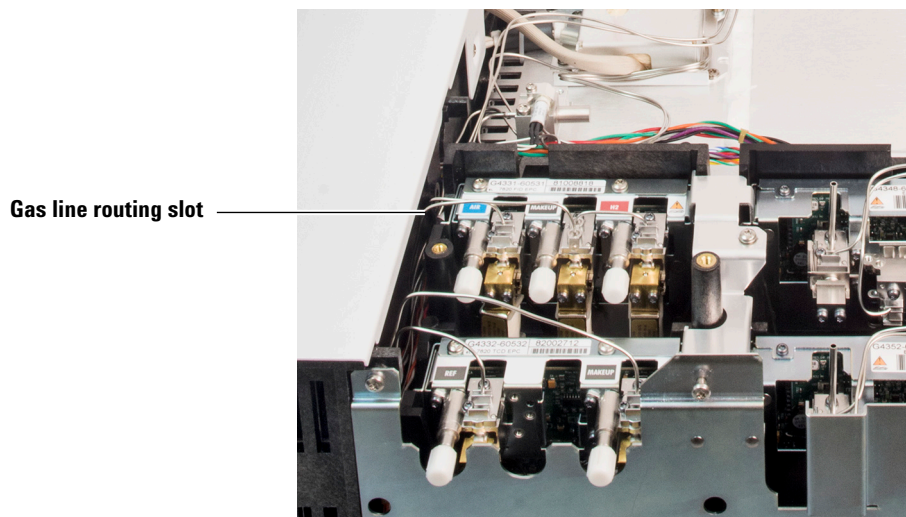

Figure 5 Detector gas line routing slot (front detector EPR slot identified)

Install the FID board

- 1 Remove the FID board from its static control bag.
- 2 Position the FID board in the frame directly under the detector position. (See [Figure 6](#).)

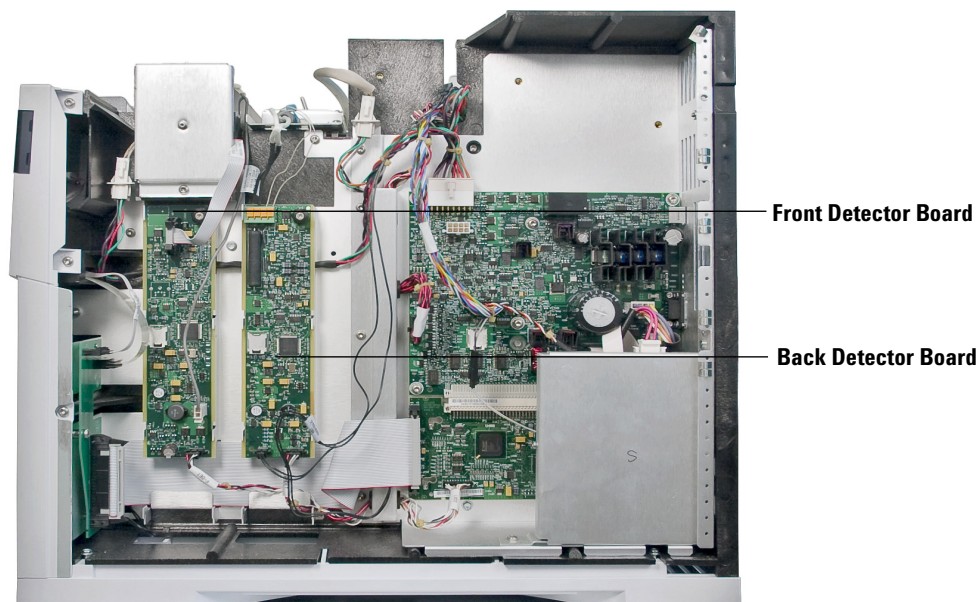

Figure 6 Locating the appropriate position for the FID board installation

- 3 Align the FID board with the frame so that the captive thumbscrew is in the upper right-hand corner and the circuits are facing out.
- 4 Starting with the board notches below the retaining hooks on the GC frame, slide the board up so that all slots engage all hooks, the board lies flat and evenly on the frame, and the captive thumbscrew aligns directly over the screw hole. (See [Figure 7](#).)

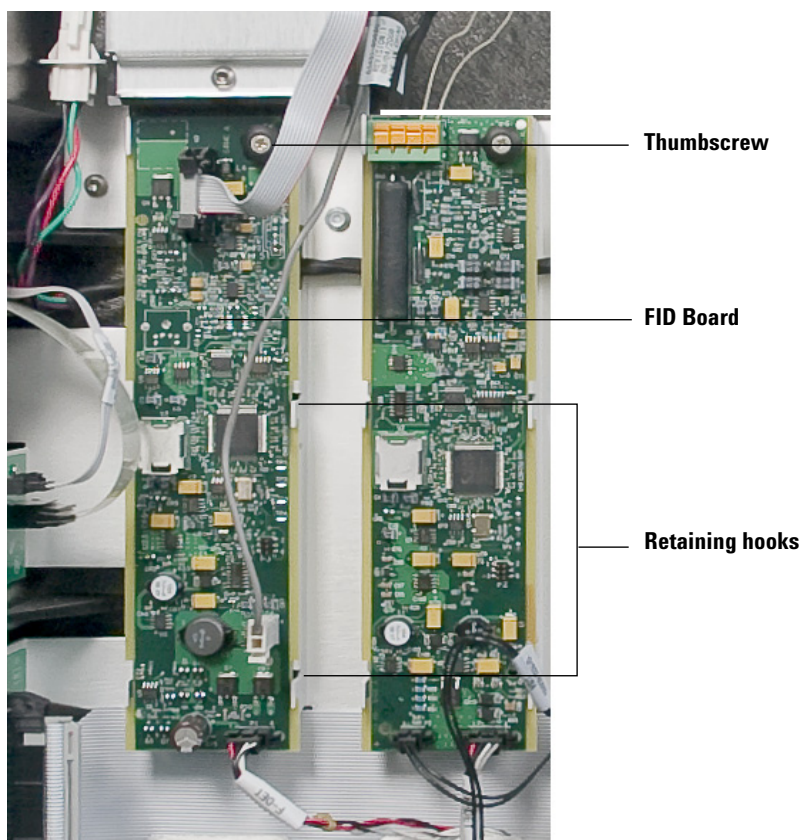

Figure 7 Attaching the FID board

5 Tighten the thumbscrew.

Connect the FID to the board

- 1 Locate the electrometer ribbon cable on the FID, and connect it to the top connector on the board. (See [Figure 8](#).)

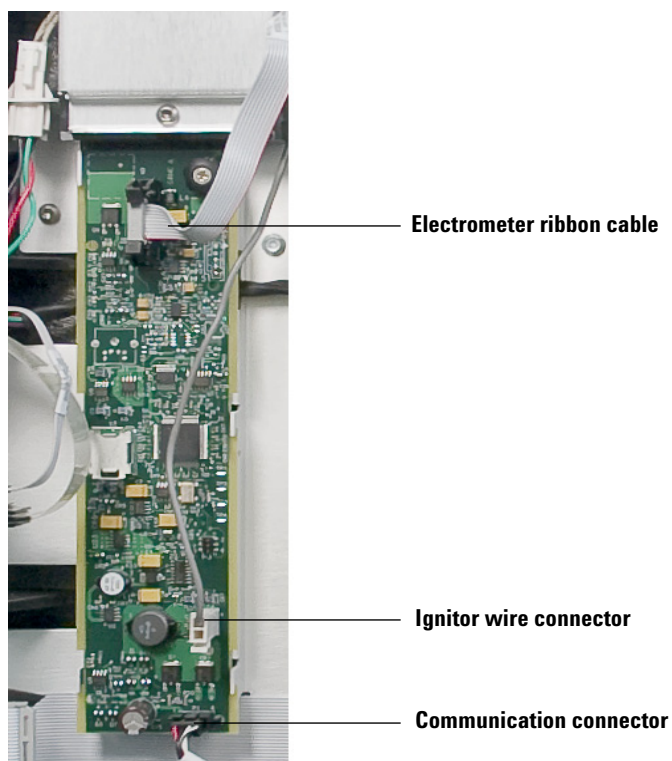

Figure 8 Connecting to the FID board

- 2 Locate the ignitor wire on the FID, and connect it to ignitor connector located on the bottom right of the FID board.
- 3 Locate the GC communication wire, and connect it to the communication connector on the FID board. The communication cable for the front detector location is labeled F-DET and the cable for the back detector location is labeled B-DET.

Install the EPR module

- 1 Remove the EPR module bracket by loosening the captive screw and lifting the bracket off the GC. (See [Figure 9](#).)

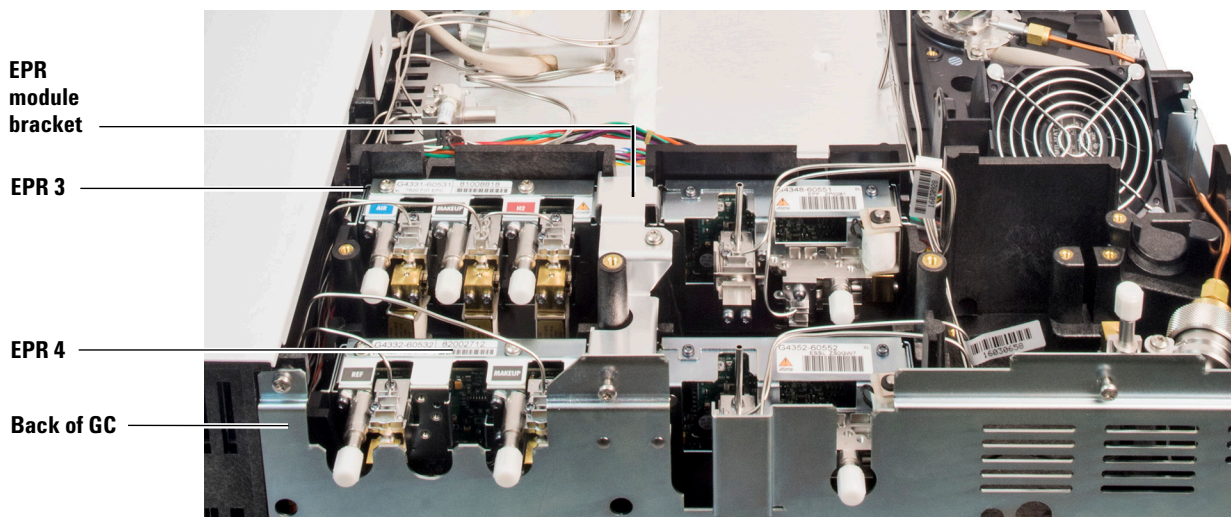

Figure 9 EPR module locations (shown with EPR modules installed)

- 2 Locate the communications cable in the detector module EPR bays area, and plug it into the connector located on the lower left side of the EPR module circuit board. (See [Figure 10](#).)

Table 3 Detector location and associated EPR information

Detector location	EPR bay location	Communications bus connection
Front	forward	EPC3
Back	rearward	EPC4

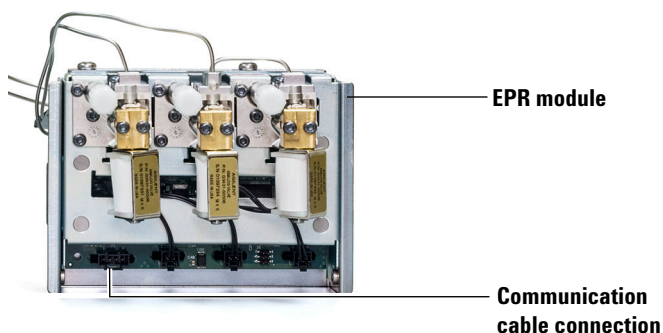

Figure 10 Communication cable connection on EPR module

- 3 Vertically slide the EPR module fully into its slot, being careful not to pinch the wires.
- 4 Orient tubing from the EPR module through the large passage provided on the detector side of the EPR bay.
- 5 Position the EPR module bracket, and secure with screw.

Install the nutwarmer cup

- 1 Open the oven door.
- 2 Insert the insulation into the nutwarmer cup, aligning the slots in the insulation with the slot on the cup.
- 3 Press the wire spring lever at the bottom of the cup to the right to uncover the hole. (See [Figure 11](#).)

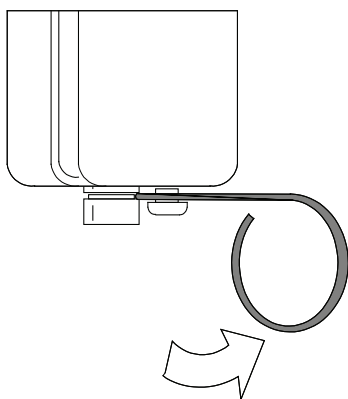

Figure 11 Uncovering the hole for the detector fitting

- 4 In the oven, place the cup over the detector fitting so that the top of the cup is directly against the top of the oven. (See [Figure 12](#).)

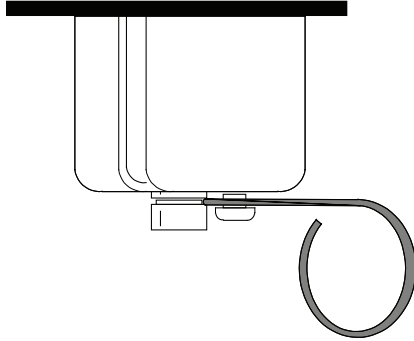

Figure 12 Insulation cup installed over detector fitting

- 5 Release the spring so that it fits in the groove of the detector fitting.

Restore the GC to operating condition

- 1 Replace the right side and top electronics covers in the reverse order that they were removed.
- 2 Plug in the GC, and turn on its power.
- 3 Ensure the GC is connected to the Agilent 7820A GC software, and access the GC operation keypad. For more information on connecting to the software, see the GC Advanced User Guide.
- 4 On the software keypad, click [**Config**] [**Lite EPC#**].
- 5 Use the Up or Down arrows to select **EPC1** or **EPC2** as the EPR module to control gas flow to the detector you are installing.
- 6 Click [**Mode/Type**], and select the **Front Detector** or **Back Detector** position and click [**Enter**]. This must match the location of the detector's installation.
- 7 Follow the prompts in the software keypad display. Click [**Enter**] to continue when prompted. At a minimum, you will be prompted to close your online data session, then reboot the GC.
- 8 On the software keypad, click [**Config**], then [**Front Det**] or [**Back Det**].
- 9 On the unconfigured parameter, click [**Mode/Type**].
- 10 Select **Install Detector (FID)**, and click [**Enter**]. A caution message will appear instructing you to reboot.
- 11 Reboot the GC.
 - a Click [**Options**].
 - b Scroll to **Communications**, and click [**Enter**].
 - c Scroll to **Reboot the GC?**, and click [**On/Yes**] twice to reboot the GC and allow the changes to take effect.
- 12 The new EPR module you have installed *must* be properly calibrated before the detector is ready for application use. To calibrate the pressure and gas type, refer to the Calibration section of the Advanced User Guide.

CAUTION

Be careful not to cross-thread the knurled nuts onto the supply fittings.

-
- 13 Attach the detector gases after completing pressure and gas type configuration, and connect the gas source lines (**AIR**, **MAKEUP**, and **H2**) to the EPR module.
 - 14 Restore gas pressure, and leak check all fittings.
 - 15 Replace the pneumatics cover, and the detector cover.



Warranty

The material contained in this document is provided "as is," and is subject to being changed, without notice, in future editions. Further, to the maximum extent permitted by applicable law, Agilent disclaims all warranties, either express or implied, with regard to this manual and any information contained herein, including but not limited to the implied warranties of merchantability and fitness for a particular purpose. Agilent shall not be liable for errors or for incidental or consequential damages in connection with the furnishing, use, or performance of this document or of any information contained herein. Should Agilent and the user have a separate written agreement with warranty terms covering the material in this document that conflict with these terms, the warranty terms in the separate agreement shall control.

© Agilent Technologies, Inc. 2016
Printed in USA and China
First edition, August 2016
Agilent Technologies, Inc.
2850 Centerville Road
Wilmington, DE 19808-1610 USA

安捷伦科技(上海)有限公司
上海市浦东新区外高桥保税区
英伦路412号
联系电话: (800) 820 3278



G4331-90020