

Analysis of Suspected Flavor and Fragrance Allergens in Perfumes Using Two-Dimensional GC with Independent Column Temperature Control Using an LTM Oven Module

Application Note

Food and Flavors

Authors

Frank David
Research Institute for Chromatography
Pres. Kennedypark 26, B-8500 Kortrijk
Belgium

Matthew S. Klee
Agilent Technologies, Inc.
2850 Centerville Road
Wilmington, DE 19808-1610
USA

Abstract

Several different analytical methods based on GC/MS are used for the determination of flavor and fragrance allergens in raw materials and cosmetic products in accordance with EU Directive 2003/15/EC. For complex perfume samples with possible coelution of target compounds with other solutes, two-dimensional GC with heartcutting is preferred.

In this application note, a multidimensional capillary GC method is presented coupling Deans switch heartcutting with GC/MS and a low thermal mass (LTM) column module for optimal separation and quantitation of regulated allergens in complex samples. The method was applied to a perfume sample containing several regulated allergens. By using an LTM column module, the temperature of the second column could be controlled independently from the primary column in the main GC oven. Allergens were heartcut to the LTM at 50 °C, where they were focused and then later separated in an independent temperature program, resulting in optimum selectivity and better resolution of target compounds from sample matrix.



Agilent Technologies

Introduction

Recent European regulation requires allergen compounds to be monitored in fragranced products [1]. The target compounds include some common organic compounds such as limonene, citral, and cinnamic aldehyde. These compounds are often detected in natural products but can cause irritation to sensitive skin. According to the regulation, cosmetic products should therefore be labeled if the allergens are present above specified concentrations (10 ppm in "leave-on" and 100 ppm in "rinse-off" products). Consequently, effective methods are needed for qualitative and quantitative determination of the targeted compounds in these complex matrices.

The official target compound list includes 24 compounds. Some of the solutes consist of more than one chemical identity. Citral consists of two isomers: neral (Z citral) and geranial (E citral). Lyral also contains two isomers: (3- and 4-(4-hydroxy-4-methylpentyl)-3-cyclohexene-1-carboxaldehyde). Farnesol consists of at least four possible isomers, of which the Z,E (farnesol 1) and E,E isomer (farnesol 2) are the predominant compounds observed. In addition, some related compounds, such as phenylacetaldehyde, estragole, methyl 2-nonynoate, and methyleugenol are also monitored [2]. In total, 31 target compounds are analyzed. The list of solutes is given in Table 1 and the first dimension separation is shown in Figure 1.

Table 1. Target Allergen List in Order of Elution on the Agilent J&W HP-5MS Column

Peak number	Compound
1	Limonene
2	Benzyl alcohol
3	Phenyl acetaldehyde
4	Linalool
5	Estragol
6	Methyl 2-octynoate (= folione)
7	Citronellol
8	Neral
9	Geraniol
10	Geranial
11	Cinnamaldehyde
12	Anisyl alcohol
13	Hydroxy citronellal
14	Methyl 2-nonynoate (methyl octane carbonate)
15	Cinnamic alcohol
16	Eugenol
17	Methyleugenol
18	Coumarin
19	Isoeugenol
20	Alpha isomethyl ionone
21	Lilial (BMHCA)
22	Amyl cinnamaldehyde
23	Lyral 1
24	Lyral 2
25	Amyl cinnamyl alcohol
26	Farnesol 1
27	Farnesol 2
28	Hexyl cinnamaldehyde
29	Benzyl benzoate
30	Benzyl salicylate
31	Benzyl cinnamate

The range of matrices in which the target compounds have to be measured is very broad and includes natural essential oils, synthetic mixtures of flavor and fragrance compounds, natural product extracts, and finished products, such as soaps, gels, shower gels, lipsticks, and other cosmetic products.

Moreover, the range of concentrations of the fragrance compounds in these matrices is very wide (from high ppb to percent). It is clear that to analyze all target compounds in all classes of matrices using one single method would be impossible. Therefore we have proposed classifying the different matrices into four classes [3]. For each class, dedicated analytical methods have been developed and validated. Direct injection of a diluted sample and analysis by one-dimensional GC/MS either in scan mode [4] or selected ion monitoring (SIM) mode is effective for samples that contain solutes that elute on an apolar column between decane (retention index 1000) and docosane (retention index 2200), providing that the sample complexity and analyte concentration range are not high, and that no nonvolatile matrix compounds are present [2]. One such method was developed using an Agilent J&W HP-5MS (apolar) column. The conditions and corresponding retention time locked information [5] and a complete allergens deconvolution reporting software (DRS) database with peak deconvolution are available from the Agilent Technologies Web site (www.agilent.com).

For highly complex samples (> 100 solutes) containing only volatile and semivolatile solutes, or for samples with a very broad concentration range of components (for example: very low concentrations of target compounds in a very high concentration of matrix compounds), a single-dimension GC separation is not effective. For these, the added power of two-dimensional capillary GC (GC/GC, 2D GC) has been shown to be helpful [3]. Using multiple heartcuts from a primary apolar column, target compounds can be isolated and resolved from interfering sample components on a polar secondary column, making accurate quantification possible even in cases where MS deconvolution of one-dimensional GC/MS data fails.

In this paper, the application of capillary flow technology Deans switching is demonstrated for the 2D GC analysis of a complex perfume sample. For even more method flexibility and separation power, the second-dimension column was housed in a low thermal mass (LTM) oven module for independent control of the column temperature. With this configuration, multiple heartcuts could be focused on the cooler secondary column and then released with an independent temperature program, which could be independently optimized for best separation of target compounds from complex sample matrix.

Experimental

The perfume sample was diluted to 5% (50 mg/mL) in acetone. Standard solutions were prepared from pure compounds at 100 ng/ μ L in acetone.

The analyses were performed on a 7890A GC/5975 MSD combination. The GC was equipped with an SSL inlet, FID detector, a capillary flow technologies based Deans switching system (p/n G2855B), a PCM flow module (option #309), and an LTM system controller bundle (p/n G6579A).

As illustrated in Figure 2, the primary column was installed in the GC oven and configured from the split/splitless inlet to the Deans switch. "Long leads" were requested when

ordering the column for the LTM so that the inlet end could be connected directly to the Deans switch. The outlet of the column was cut close to the column module and connected to the MSD via uncoated but deactivated fused silica (FS) tubing using an Agilent Ultimate Union (p/n G3182-61580). This configuration results in better method translation of conditions than when the long lead is left on the outlet end of the column because this 1 m extends into the GC column oven and becomes an isothermal (third) separation zone that broadens peaks and can alter the relative retention and resolution achieved at the exit of the LTM module. A restrictor (uncoated but deactivated retention gap) was also connected between the second output of the Deans switch and a monitoring FID. The conditions are summarized in Table 2.

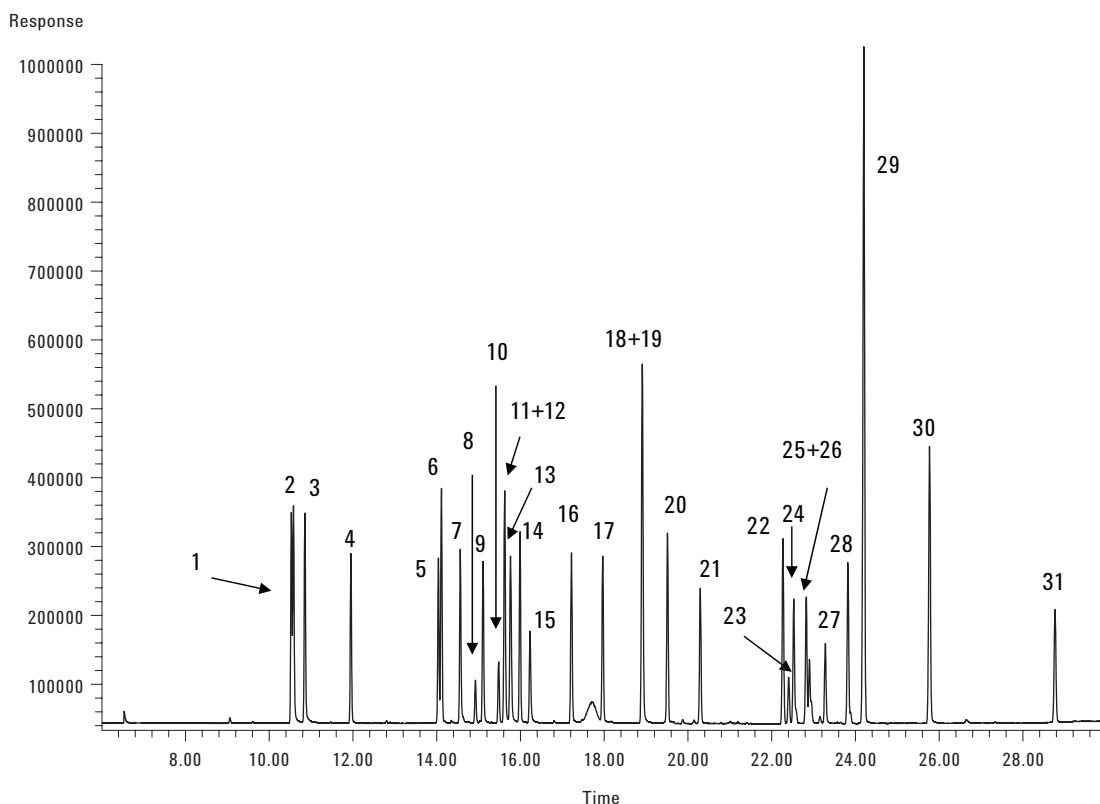

Figure 1. Separation of flavor and fragrance allergen test mixture (100 ppm) on the first dimension column (Agilent J&W HP-5MS) and FID detection. Peak identification is given in Table 1.

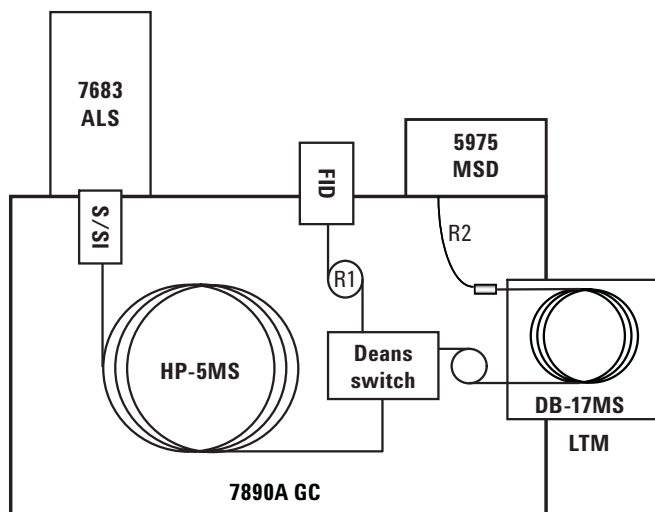

Figure 2. System configuration.

Results and Discussion

First, a standard mixture containing all target compounds at 100 ng/μL was analyzed. No heartcutting was used. The resulting chromatogram from the separation on the J&W HP-5MS column on the monitor FID is given in Figure 2. A good separation was obtained. Some coeluting pairs can effectively be resolved by mass spectral deconvolution (specific ions), as is done with DRS methods.

Next, the perfume sample was run under the same conditions. The chromatogram from the monitor FID detector shown in Figure 3A shows that the perfume is very complex, making determination of target compounds difficult. Some target solutes, such as linalool (peak 4) and alpha-isomethyl ionone (peak 20) are clearly resolved and can be determined. However, the elution window between 22 and 24.5 min, is quite complex. In this window, several target allergens elute,

Table 2. Analytical Conditions

Injection	1.0 μL
Inlet	S/SI, 250 °C, split ratio = 1:25
Column 1 (Carrier gas = He)	30 m × 0.25 mm id × 0.25 μm Agilent J&W HP-5MS, p/n 19091S-433 Flow = 1.4 mL/min; constant flow mode (185 kPa at 50 °C) Inlet = SSL; outlet = PCM1
Column 2 (LTM) (Carrier gas = He) Flow (PCM1)	30 m × 0.25 mm id × 0.25 μm Agilent J&W DB-17ms, p/n 122-4732LTM with "long leads" (1 m at each end not wrapped) 2 mL/min constant flow mode (120 kPa at 50 °C) for first experiment, 120 kPa (1 min) → 256 kPa (28 min) at 4.35 kPa/min for second experiment
Restrictors	R1 = 63 cm × 100 μm id deactivated FS (cut from, for example, p/n 160-1010-5) R2 = 1 m × 250 μm id deactivated FS (p/n 160-2255-1)
GC oven temperature	50 °C (1 min) → 300 °C (27.75 min) at 8 °C/min Total run time = 60 min
LTM oven	50 °C (25 min, after last heartcut) → 250 °C (1 min) at 6 °C/min (Total run time = 60 min)
FID monitor detector	300 °C, 30 mL/min H ₂ , 400 mL/min air
Deans switch heartcutting	Initially OFF Cut 1: ON at 10.2 min, OFF at 11.0 min Cut 2: ON at 15.3 min, OFF at 16.4 min Cut 3: ON at 22.0 min, OFF at 24.5 min
MS data acquisition	Autotune, scan mode, 41–300 u, samples = 2 ²
MSD transfer line	300 °C
MS solvent delay	5 min
MS temperatures	Source = 300 °C, quad = 150 °C

including amyl cinnamaldehyde, lylal (two isomers), amyl cinnamyl alcohol (with a related impurity), farnesol (two isomers), hexyl cinnamaldehyde, and benzyl benzoate. Within the same window, interfering perfume constituents such as methyl dihydrojasmonate, ionones, and sesquiterpenes elute. Most of these have mass spectra with strong fragmentation, resulting in many nonspecific low mass ions, interfering significantly with target ion spectra and ion ratios. Traditional selective detection and quantification using SIM data or deconvolved scan data from DRS that are effective with simpler samples would therefore be problematic with this sample.

For example, confirming the presence of lylal in this sample was difficult with the simpler approach. With GC-SIM-MS, it was not possible to accurately quantify lylal, and its qualifier

ions did not fall within the specified range. Review of the scan data clearly showed the presence of coeluting interferences.

Next, the sample was rerun with three heartcuts, including the problematic region between 22 and 24.5 minutes, which were heartcut to the second column. Propylene glycol, used as "keeper" in some perfumes, is a potential interferent in the first window that contains limonene, benzylalcohol, and phenylacetaldehyde. Quantification and identification of hydroxycitronellal in the second heartcut window is another component that, in the presence of interferences, is sometimes problematic to quantify using standard methods. The chromatogram obtained on the monitor detector is shown in Figure 3B, wherein the three heartcut windows show up as flat sections in the baseline.

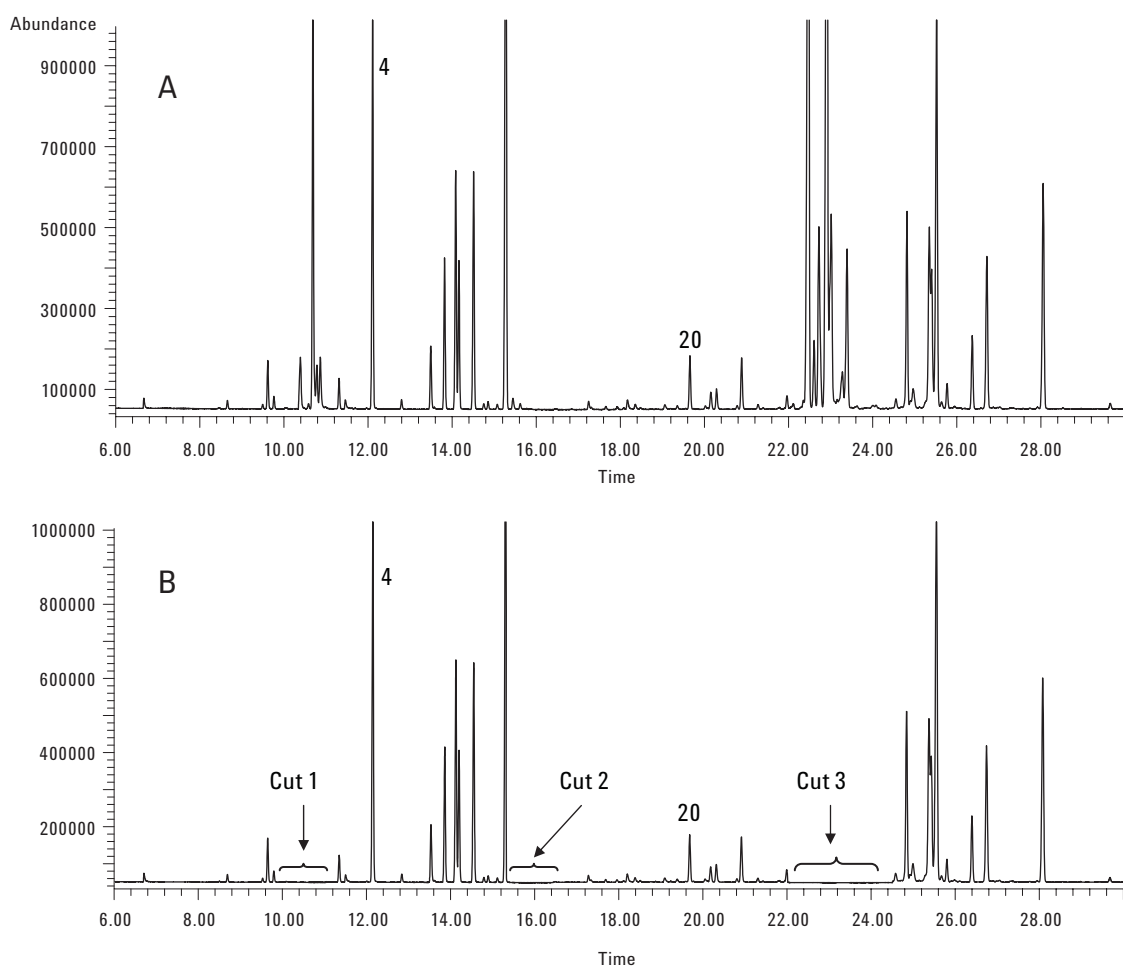

Figure 3. A) Separation of a perfume sample on the first-dimension column (Agilent J&W HP-5MS) using FID detection without heartcutting. Peaks: 4. Linalool; 20. Alpha-isomethyl ionone. B) Separation of a perfume sample on the first-dimension column (Agilent J&W HP-5MS) using FID detection with heartcutting (fractions: 10.2–11.0, 15.3–16.4, and 22.0–24.5 min).

The TIC chromatogram obtained after separation on the second-dimension column of the lyral fraction (heartcut 3) is shown in Figure 4A. First the analysis was performed using the same temperature program for the second column as for the first column (LTM program = 7890A oven program), emulating what would happen if the secondary column were housed in the GC oven (traditional configuration 2D GC). At least eight peaks were detected. The lyral isomers elute at 25.4 and 25.5 minutes. The second isomer, however, coelutes with another solute, and confirmation and quantification are not possible. The elution temperature of the lyral isomers in this case was around 240 °C. Both retention and selectivity at this temperature are low.

The experiment was repeated, this time with the J&W DB-17ms secondary column kept at 50 °C until the last heart-

cut was completed, and then the temperature was increased (at 6 °C/minute). Using this approach, the solutes are first focused at the head of the LTM column, and then elute at lower temperature (200 °C) during the temperature ramp, allowing both retention and selectivity to play more important roles. An added benefit is that the peak widths are narrowed due to the focusing, which improves peak resolution. Under these conditions, the isomers elute at 49.25 and 49.4 minutes and can be quantified without interference. The chromatogram of heartcut fraction 3 (22 to 24.5 minutes from column 1) is shown in Figure 4B. In contrast to Figure 4A, at least 20 peaks spanning a wide concentration range are clearly resolved. The presence of lyral isomers in the sample could thereby be confirmed and accurately quantified.

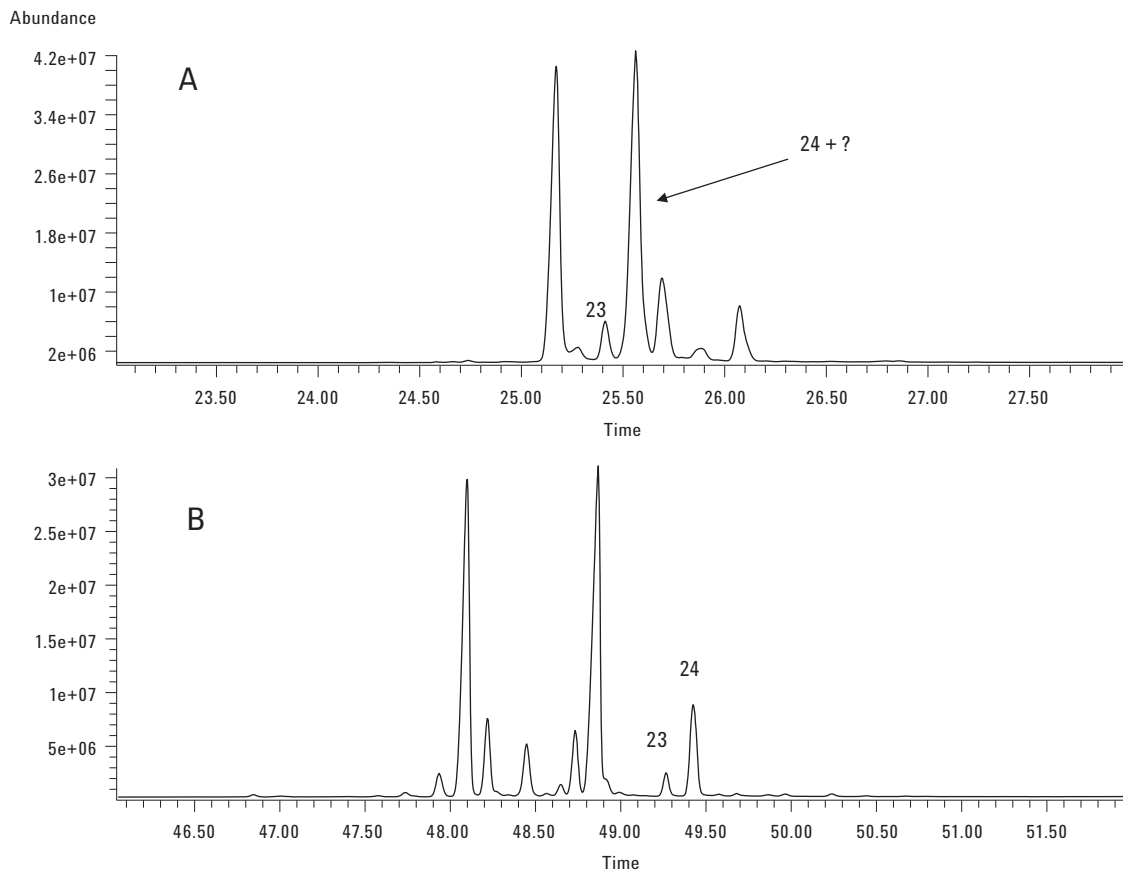

Figure 4. A) Separation of fraction 3 on the second-dimension column (Agilent J&W DB-17ms) using MS detection. Column 1 temperature = column 2 temperature: 50 °C (1 min) → 270 °C at 8 °C/min. Peaks: 23. Lyral 1; 24. Lyral 2. B) Separation of fraction 3 on the second-dimension column (Agilent J&W DB-17ms) using MS detection. Column 2 temperature: 50 °C (25 min) → 250 °C at 6 °C/min. Peaks: 23. Lyral 1; 24. Lyral 2.

By comparing the chromatograms in Figure 4, it is obvious that the independent temperature control of the second column in a 2D GC greatly increases the ability to optimize selectivity and resolution. This point was also demonstrated in the analysis of enantiomers using a chiral second-dimension column [6].

In addition to perfume samples, the approach presented herein can also be used for the determination of flavor and fragrance allergens in finished products. In these applications, any nonvolatile or late-eluting matrix compounds could be backflushed from the first-dimension column, as discussed in a manner similar to that described in an earlier application note [7].

Conclusions

Two-dimensional GC using Deans switch heartcutting in combination with MS can be used for the determination of flavor and fragrance allergens in complex perfume and cosmetic samples. Using LTM technology, the second dimension column temperature can be optimized independently from the primary column, resulting in better selectivity and resolution of target solutes from matrix interferences. Addition of an LTM module is more cost-effective, less cumbersome to configure, and takes up less space than if using a second GC as the independent zone.

References

1. Directive 2003/15/EC, Official Journal of the European Union, 6 66/26, 11.3.2003
2. A. Chaintreau, D. Joulain, C. Marin, C.-O. Schmidt, and M. Vey, *J. Agric. Food Chem.*, 2003, 51: 6398–6403
3. F. David, C. Devos, and P. Sandra, *LC.GC Europe* 19, Nov 2006, 602–616
4. H. Leijts, J. Broekhans, L. van Pelt, and C. Mussinan, *J. Agric. Food Chem.*, 2005, 53: 5487–5491
5. W. Luan, C. Sandy, and M. Szelewski, "Determination of Allergens in Fragrance Products Using Agilent Deconvolution Reporting Software," Agilent Technologies publication 5989-8724EN, June 2008
6. F. David and M.S. Klee, "Independent Column Temperature Control Using an LTM Oven Module for Improved Multidimensional Separation of Chiral Compounds," Agilent Technologies publication 5990-3428EN, January 2009
7. F. David and M.S. Klee, "Analysis of Suspected Flavor and Fragrance Allergens in Cosmetics Using the 7890A GC and Capillary Column Backflush," Agilent Technologies publication 5989-6460EN, March 2007

For More Information

For more information on our products and services, visit our Web site at www.agilent.com/chem.

www.agilent.com/chem

Agilent shall not be liable for errors contained herein or for incidental or consequential damages in connection with the furnishing, performance, or use of this material.

Information, descriptions, and specifications in this publication are subject to change without notice.

© Agilent Technologies, Inc., 2009
Printed in the USA
February 12, 2009
5990-3576EN



Agilent Technologies