

# A New Test Method for the Determination of Derivatized Chemical Species in Marine Fuel Oil by Multidimensional GC/MS

## Authors

Carmen Sanchez Fermin  
Intertek

George Gonzalez  
Agilent Technologies, Inc.

## Abstract

This application note presents a test method procedure and multidimensional gas chromatography/mass spectrometry (GC/MS) conditions used to test for the following target compounds: fatty acids, fatty acid methyl esters (FAME), fatty acid monoglycerides, bisphenol A, bisphenol F, benzenediols, and 4-cumylphenol in bunker fuel oil. This test method was developed for committee ISO TC28 SC4 WG6 to address testing requirements for the target compounds. An Agilent 7890 GC was configured according to the standard test method ASTM D7845-20. This test method uses sample derivatization for sample preparation. The GC/MS system provided excellent linear working range and precision for all the compounds analyzed.

## Introduction

Marine fuel oil is a type of commercial fuel for ocean vessel operation. Deleterious chemical contaminants in marine fuel oil have occasionally been suspected of ocean vessel engine fouling at great cost to ship owners. The industry relies on lab testing to analyze marine fuel oil for chemical contaminants using various test methods.

The test method described in this application note was developed as requested by committee ISO Technical Committee 28 SC4 WG6 SG10 on marine fuel oil for specification ISO 8217. The request is for an expanded scope and for the analysis of specific chemical species (defined in this application note). The emergence of potential bunker fuel oil contamination from other sources necessitates a new test method based on recent identification of suspect deleterious compounds.

The method presented here is for the determination of chemical species in marine fuel oil consisting of bunker fuel oil and other heavy petroleum blend stocks. The test method provides the sample preparation procedure, GC/MS setup, and calibration parameters required to test for fatty acids, FAME, fatty acid monoglycerides, bisphenol A, bisphenol F, benzenediols, and 4-cumylphenol in bunker fuel oil. The method will be used to establish a new ASTM standard test method. It has been registered as ASTM work item number 85821 – "Test Method for Determination of Derivatized Chemical Species in Marine Fuel Oil by Multidimensional Gas Chromatography/Mass Spectrometry".

## Experimental

### Instrument configuration and operating conditions

A 7890 GC and an Agilent 5977B GC/MSD were configured according to ASTM D7845 conditions. This system was configured using a 1 m precolumn (taken from an Agilent J&W DB-1 GC column, 10 m × 150 μm, 1.2 μm, part number 12A-1015), and an Agilent J&W HP-1 GC column, 100 m × 250 μm, 0.5 μm (part number 19091Z-530). The Purged Ultimate Union backflush system was configured as described in ASTM D7845-20, Appendix X2.1, Figure X2.1 (Figure 1).

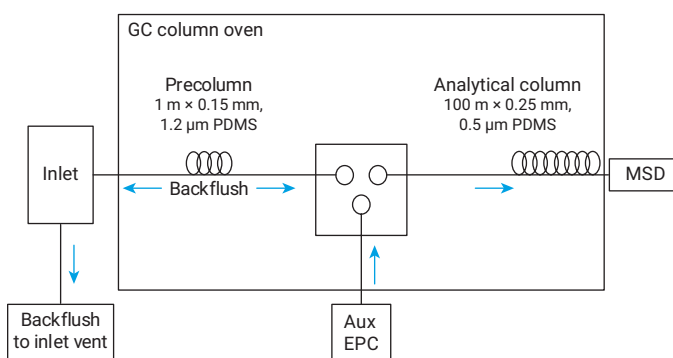

**Figure 1.** Agilent Purged Ultimate Union backflushing.

The operating conditions were developed for the analysis of fatty acids, FAME, fatty acid monoglycerides, bisphenol A, bisphenol F, benzenediols, and 4-cumylphenol in bunker fuel oil. The configuration and operating conditions used for this testing are shown in Tables 1 and 2.

**Table 1.** Gas chromatograph conditions.

Parameter	Value
Split/Splitless Inlet	325 °C
Injection Volume	1 µL
Inlet Liner	Agilent inlet liner, Ultra inert, splitless, double taper (p/n 5190-3983)
Septum Purge Flow	3 mL/min
Split Ratio	25:1
Total Flow	29 mL/min
Carrier Gas	Helium
Pressure	42.298 psi
Average Velocity	35.369 cm/sec
Precolumn	Agilent J&W DB-1 GC column, 10 m × 150 µm, 1.2 µm (use 1 m section)
Precolumn Flow	Initial 1 mL/min (hold for 15 min), ramp 10 mL/min to -1 mL/min (hold for 0 min)
Average Velocity	35.369 cm/s
Precolumn Outlet	Purged Ultimate Union
Analytical Column Inlet	Purged Ultimate Union
Analytical Column	Agilent J&W HP-1 GC column, 100 m × 250 µm, 0.5 µm
Carrier Supply.	Aux 1 (helium)
Pressure	40.467 psi
Flow	1.2 mL/min
Average Velocity	22.744 cm/sec
Holdup Time	7.3281 min
Outlet	MSD
Column Oven Temperature	140 °C (hold for 0 min), ramp 10 °C/min to 325 °C (hold for 20 min)

**Table 2.** Mass spectrometer conditions.

Parameter	Value
MSD Transfer Line Temperature	325 °C
Acquisition Mode	Scan
MS Tuning	Autotune
Scanning Mode	Normal
Ionization Voltage	70 eV, fixed operating condition
Mass Scan Range	m/z 45 to 520
A/D Samples	4
MS Source	300 °C
MS Quadrupole	150 °C

## Calibration standards

Mass spectral quantifying and qualifying ions are defined in Table 3. The mass-based multipoint calibration standards are shown in Table 4. The concentrations used were chosen based on the preferred industry operating range.

**Table 3.** Mass spectral ions.

Compound	CAS Number	Quant Ion m/z	Qualifier m/z	Qualifier m/z	Qualifier m/z
Propenoic Acid	79-10-7	129	144	-	-
4-Methethyl Phenol	99-89-8	193	208	151	-
1,2 Dihydroxy Benzene	120-80-9	254	239	151	-
1,3 Dihydroxy Benzene	108-46-3	254	239	147	-
1,4 Dihydroxy Benzene	123-31-9	239	254	112	-
Lauric Acid	143-07-7	257	272	-	-
Methyl Myristate	124-10-7	199	242	-	-
Methyl Palmitoleate	1120-25-8	236	268	-	-
Methyl Palmitate	112-39-0	227	270	271	74
4-Cumyl Phenol	599-64-4	269	284	-	-
Methyl Margarate	1731-92-6	284	241	-	-
Palmitic Acid	57-10-3	313	328	-	-
Methyl Linoleate	112-63-0	294	263	-	-
Methyl Oleate	112-62-9	264	296	222	-
Methyl Linolenate	301-00-8	292	261	236	-
Methyl Stearate	112-61-8	298	255	267	-
Margaric Acid	506-12-7	327	344	342	-
Bisphenol F	620-92-8	344	329	-	-
Internal Standard – Stearic Acid-d <sub>35</sub>	17660-51-4	376	391	-	-
Oleic Acid	112-80-1	339	354	145	-
Linolenic Acid	463-40-1	335	350	285.1	-
Bisphenol A	80-05-7	357	372	-	-
Stearic Acid	57-11-4	341	356	-	-
Methyl Arachidate	1120-28-1	326	283	-	-
Abietic Acid	514-10-3	374	359	256	-
Methyl Behenate	929-77-1	354	311	-	-
Monopalmitin	542-44-9	371	459	-	-
Monoolein	111-03-5	397	500	485	-
Monostearin	123-94-4	399	487	-	-

**Table 4.** Compound calibration summary.

Compound	CAS Number	Level 1	Level 2	Level 3	Level 4	Level 5
Propenoic Acid	79-10-7	0.0037	0.0087	0.0168	0.0251	0.0414
4-Methyethyl Phenol	99-89-8	0.0035	0.0083	0.0161	0.0240	0.0396
1,2 Dihydroxy Benzene	120-80-9	0.0070	0.0165	0.0319	0.0478	0.0788
1,3 Dihydroxy Benzene	108-46-3	0.0032	0.0076	0.0147	0.0220	0.0362
1,4 Dihydroxy Benzene	123-31-9	0.0075	0.0176	0.0342	0.0512	0.0844
Lauric Acid	143-07-7	0.0065	0.0154	0.0299	0.0448	0.0738
Methyl Myristate	124-10-7	0.0046	0.0110	0.0212	0.0318	0.0524
Methyl Palmitoleate	1120-25-8	0.0045	0.0107	0.0208	0.0312	0.0514
Methyl Palmitate	112-39-0	0.0029	0.0070	0.0135	0.0202	0.0333
4-Cumyl Phenol	599-64-4	0.0045	0.0107	0.0207	0.0311	0.0512
Methyl Margarate	1731-92-6	0.0054	0.0128	0.0249	0.0372	0.0614
Palmitic Acid	57-10-3	0.0040	0.0095	0.0185	0.0276	0.0455
Methyl Linoleate	112-63-0	0.0041	0.0097	0.0188	0.0282	0.0465
Methyl Oleate	112-62-9	0.0041	0.0097	0.0189	0.0282	0.0465
Methyl Linolenate	301-00-8	0.0033	0.0078	0.0152	0.0227	0.0374
Methyl Stearate	112-61-8	0.0045	0.0105	0.0204	0.0306	0.0504
Margaric Acid	506-12-7	0.0063	0.0150	0.0291	0.0435	0.0717
Bisphenol F	620-92-8	0.0032	0.0076	0.0147	0.0220	0.0362
Internal Standard – Stearic Acid-d <sub>35</sub>	17660-51-4	0.0071	0.0169	0.0327	0.0490	0.0808
Oleic Acid	112-80-1	0.0041	0.0097	0.0188	0.0282	0.0464
Linolenic Acid	463-40-1	0.0050	0.0118	0.0228	0.0341	0.0563
Bisphenol A	80-05-7	0.0084	0.0199	0.0386	0.0579	0.0954
Stearic Acid	57-11-4	0.0048	0.0115	0.0222	0.0333	0.0548
Methyl Arachidate	1120-28-1	0.0045	0.0106	0.0205	0.0308	0.0507
Abietic Acid	514-10-3	0.0042	0.0099	0.0192	0.0288	0.0475
Methyl Behenate	929-77-1	0.0068	0.0161	0.0312	0.0467	0.0770
Monopalmitin	542-44-9	0.0051	0.0122	0.0236	0.0354	0.0584
Monoolein	111-03-5	0.0051	0.0120	0.0233	0.0348	0.0574
Monostearin	123-94-4	0.0053	0.0124	0.0241	0.0361	0.0595

### Sample preparation

The samples were prepared by mass in a GC autosampler vial to minimize solvent consumption. The internal standard was prepared in a pyridine solution that was used as the sample dilution solvent. The internal standard solution concentration was prepared to provide an approximately 400 mg/kg concentration in the final sample preparation. Approximately 0.7 g of sample was weighed into a GC autosampler vial followed by the addition of the internal standard/pyridine

solution. The GC autosampler vial was sealed with a cap and 150 µL of the derivatizing agent was injected into the GC vial. The vial was then mixed using a vortex mixer for 45 seconds. The vial was then allowed to work through the derivatizing process for 15 minutes. The derivatization agent was composed of N,O-bis(trimethylsilyl)trifluoroacetamide with trimethylchlorosilane (BSTFA + 1% TMCS, Sigma-Aldrich part number 15238).

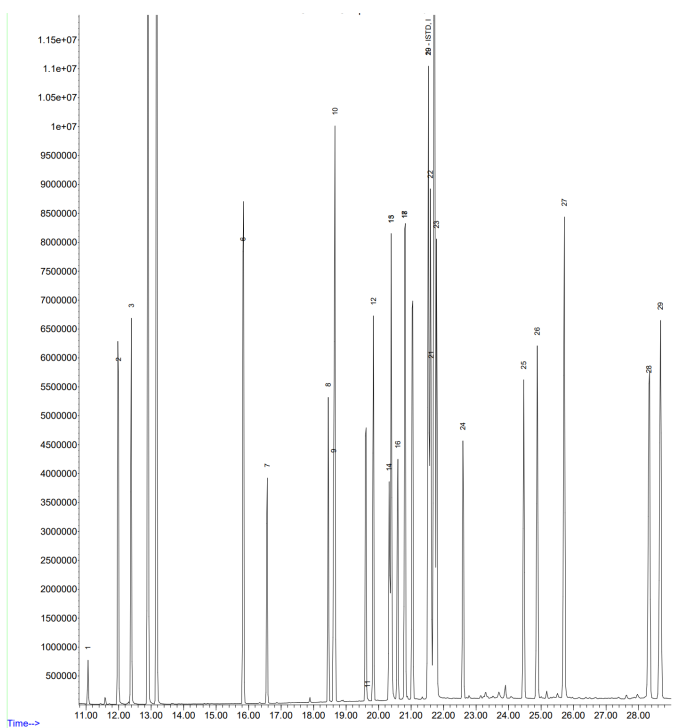

Peak No.	RT	Compound
1	11.26	Propenoic acid
2	11.98	4-Methyethyl phenol
3	12.40	1,2 Dihydroxy benzene
4	12.91	1,3 Dihydroxy benzene
5	13.18	1,4 Dihydroxy benzene
6	15.85	Lauric acid
7	16.60	Methyl myristate
8	18.44	Methyl palmitoleate
9	18.65	Methyl palmitate
10	18.67	4-Cumyl phenol
11	19.60	Methyl margarate
12	19.88	Palmitic acid
13	20.34	Methyl linoleate
14	20.39	Methyl oleate
15	20.41	Methyl linolenate

Peak No.	RT	Compound
16	20.58	Methyl stearate
17	20.81	Heptadecanoic acid
18	21.03	Bisphenol F
19	21.53	Internal standard – stearic acid-d <sub>35</sub>
20	21.54	Oleic acid
21	21.61	Linolenic acid
22	21.72	Bisphenol A
23	21.76	Stearic acid
24	22.59	Methyl arachidate
25	24.48	Abietic acid
26	24.89	Methyl behenate
27	25.67	Monopalmitin
28	28.33	Monoolein
29	28.66	Monostearin

Figure 2. Total ion chromatogram of compounds.

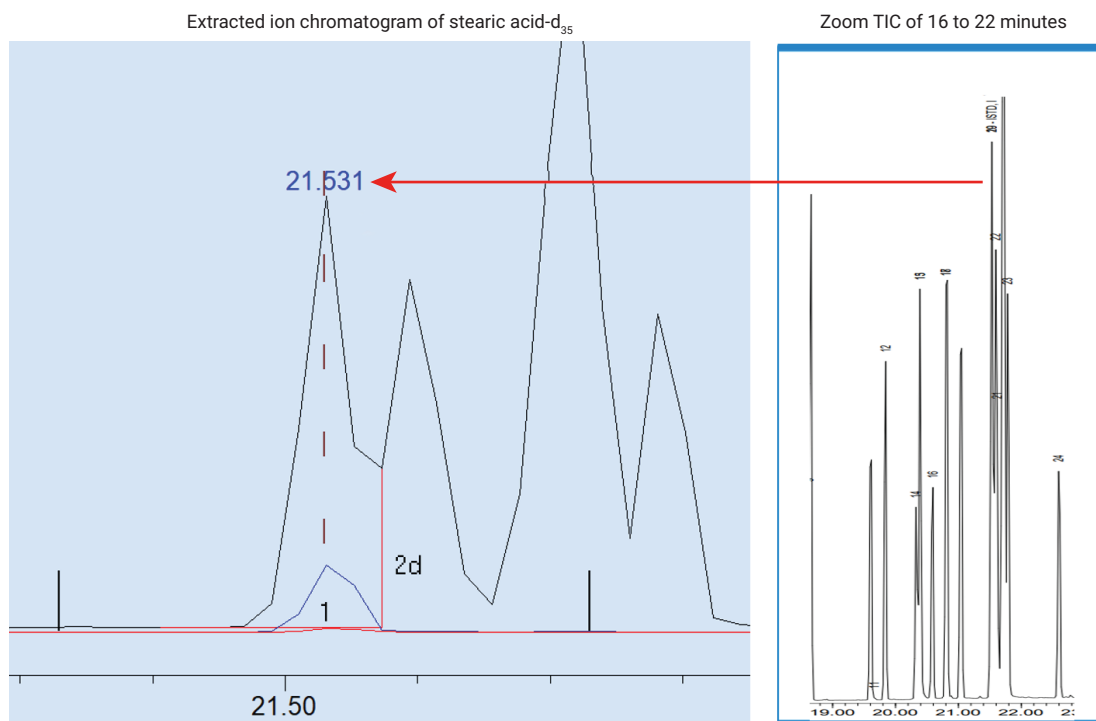

Figure 3. Extracted ion chromatogram of internal standard resolution.

## Linearity

The calibration produced exceptional correlation coefficients as shown in Table 5.

Establishing linear response for any of the target compounds can be challenging; the GC/MS system provided  $R^2$  values of 0.998 or better, except for methyl behenate at 0.9843  $R^2$ . Example calibration curves are shown in Figures 4, 5, and 6.

**Table 5.** Summary of compound linearity.

Compound	Calibration Range (mg/kg)		$R^2$
	Low	High	
Propenoic Acid	37	414	0.9993
4-Methyethyl Phenol	32	362	0.9991
1,2 Dihydroxy Benzene	35	396	0.9995
1,3 Dihydroxy Benzene	70	788	0.9993
1,4 Dihydroxy Benzene	75	844	0.9996
Lauric Acid	65	738	0.9995
Methyl Myristate	46	524	0.9989
Methyl Palmitoleate	45	512	0.9995
Methyl Palmitate	29	333	0.9998
4-Cumyl Phenol	45	514	0.9997
Methyl Margarate	32	362	0.9995
Palmitic Acid	40	455	0.9995
Methyl Linoleate	63	717	0.9983
Methyl Oleate	54	614	0.9994
Methyl Linolenate	45	504	0.9997
Methyl Stearate	41	464	0.9988
Heptadecanoic Acid	41	465	0.9995
Bisphenol F	41	465	0.9995
Internal Standard – Stearic Acid- $d_{35}$	33	374	–
Oleic Acid	45	507	0.9998
Linolenic Acid	68	770	0.9991
Bisphenol A	50	563	0.9989
Stearic Acid	71	808	0.9997
Methyl Arachidate	48	548	0.9993
Abietic Acid	51	584	0.9984
Methyl Behenate	51	574	0.9843
Monopalmitin	53	595	0.9998
Monoolein	42	475	0.9989
Monostearin	84	954	0.9997

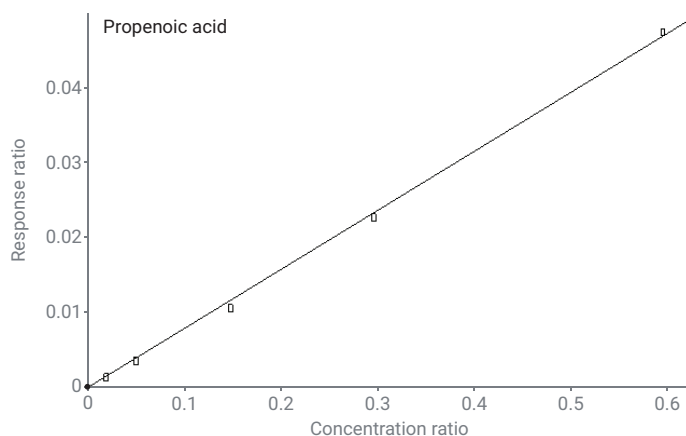

**Figure 4.** Propenoic acid calibration curve.

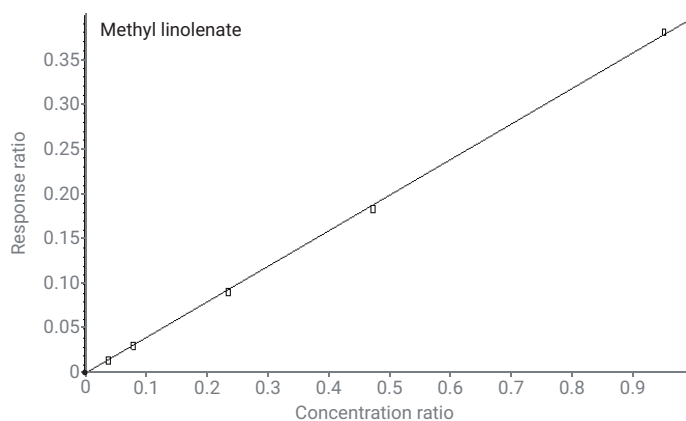

**Figure 5.** Methyl linolenate calibration curve.

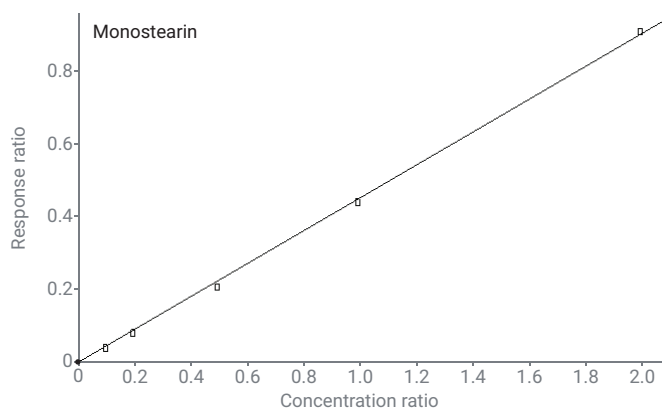

**Figure 6.** Monostearin calibration curve.

## Precision

The performance was evaluated by 14 injections of each of the three calibration standards at low (level 1), middle (level 3), and high (level 5) concentrations to determine the relative standard deviation (RSD). The results of testing each of three calibration levels will be used as the interim precision for a new ASTM standard test method. The repeatability of the system for the middle level concentration is shown in Table 6. The chromatogram of the analysis of the target compounds in the middle level calibration standard is shown in Figure 2.

**Table 6.** Compound repeatability.

Compound	Calibration Range (mg/kg)		Repeatability % RSD
	Low	High	
Propenoic Acid	37	414	7.1
4-Methyethyl Phenol	32	362	6.4
1,2 Dihydroxy Benzene	35	396	3.2
1,3 Dihydroxy Benzene	70	788	2.9
1,4 Dihydroxy Benzene	75	844	1.6
Lauric Acid	65	738	6.7
Methyl Myristate	46	524	5.6
Methyl Palmitoleate	45	512	4.5
Methyl Palmitate	29	333	3.8
4-Cumyl Phenol	45	514	2.5
Methyl Margarate	32	362	3.1
Palmitic Acid	40	455	4.1
Methyl Linoleate	63	717	6.4
Methyl Oleate	54	614	5.6
Methyl Linolenate	45	504	3.7
Methyl Stearate	41	464	6.2
Heptadecanoic Acid	41	465	5.2
Bisphenol F	41	465	4.3
Internal Standard – Stearic Acid-d <sub>35</sub>	33	374	–
Oleic Acid	45	507	2.3
Linolenic Acid	68	770	1.9
Bisphenol A	50	563	2.9
Stearic Acid	71	808	3.5
Methyl Arachidate	48	548	2.1
Abietic Acid	51	584	4.7
Methyl Behenate	51	574	5.6
Monopalmitin	53	595	3.1
Monoolein	42	475	2.9
Monostearin	84	954	4.3

## Results and discussion

The samples tested in this study included distillate fuels, very low sulfur fuel oil, cutter stock samples, and bunker fuel oil. The samples were tested using the procedure and GC/MS conditions described in this application note.

There was no mass spectral interference detected from any of the sample matrices tested during this study, based on the quantifying and qualifying ions defined in Table 3.

A bunker fuel oil sample was spiked with approximately 100 mg/kg of each of the compounds defined in Table 4. This sample was then prepared and tested using the procedure and GC/MS parameters stated in this application note.

The extracted ion chromatogram produced by testing the spiked bunker fuel oil is shown in Figure 7, which shows acceptable response and very low background signal effects.

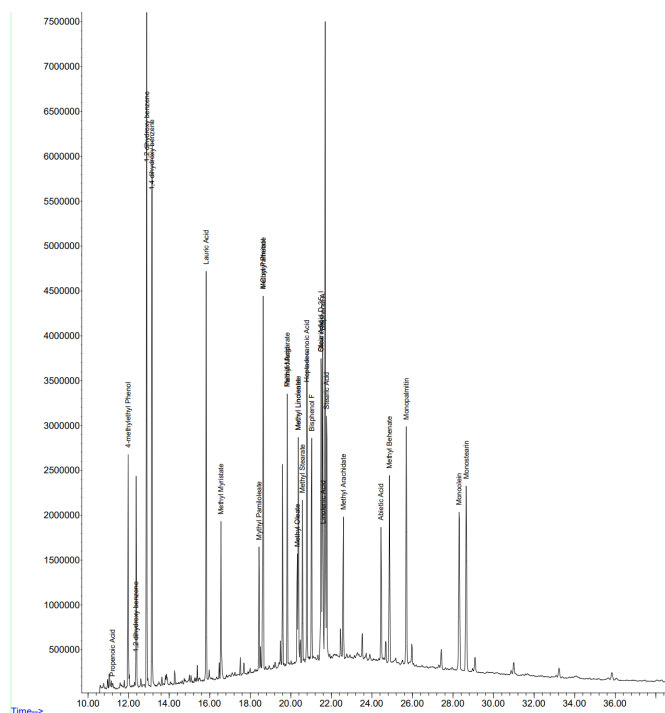

**Figure 7.** Extracted ion chromatogram of spiked fuel oil sample.

## Conclusion

The Agilent 7890 GC configured with the Agilent 5977B GC/MSD has proven to be an effective system for the detection of the compounds listed in Table 4. The sample preparation and system performance described provide detection of the target compounds within the industry-required concentration range shown in Table 4.

The Purged Ultimate Union device used provides backflushing capability to allow the analysis of a broad range of samples containing heavy hydrocarbon fractions. The procedure and multidimensional GC/MS system provided for the analysis of the target compounds. The GC/MS system was configured to meet the apparatus criteria defined in standard test method ASTM D7845-20. The user has the benefit of using the same GC/MS system for both D7845-20 and this new test method.

This test method provides for the analysis of supplemental chemical species in marine fuel oil and other petroleum products required by committee ISO TC28 SC4 WG6.

## Reference

1. American Society for Testing and Materials (ASTM) International. ASTM D7845-20: Standard Test Method for Determination of Chemical Species in Marine Fuel Oil by Multidimensional Gas Chromatography/Mass Spectrometry, *ASTM*, **2015**. <https://www.astm.org/d7845-20.html> (accessed 2023-11-24).

[www.agilent.com](http://www.agilent.com)

DE28939869

This information is subject to change without notice.

© Agilent Technologies, Inc. 2024  
Printed in the USA, February 2, 2024  
5994-7090EN