

# Analysis of Gas Products from Carbon Dioxide Use Technologies by Gas Chromatography

## Authors

Shannon Coleman and  
Kelly Beard  
Agilent Technologies, Inc.

## Abstract

Agilent has developed a robust catalyst gas analysis by gas chromatography (GC) for use in the analysis of gases produced by carbon dioxide technologies. The GC incorporates a multidimensional design, using thermal conductivity and a flame ionization detector (FID) coupled with a nickel catalyst to provide analysis of hydrogen ( $H_2$ ), oxygen ( $O_2$ ), nitrogen ( $N_2$ ), methane ( $CH_4$ ), carbon monoxide (CO), carbon dioxide ( $CO_2$ ), and  $C_1$  through  $C_6$  hydrocarbons. This design is unique in its ability to measure permanent gasses and hydrocarbons and in measuring CO and  $CO_2$  from 0.1 ppm to 100% by using the TCD and catalyst-FID combination. This detection range is beyond what is possible with a single detector for the respective compounds. The system accomplishes an expanded range of detection by using the TCD to detect  $H_2$ ,  $O_2$ ,  $N_2$ ,  $CH_4$ , CO, and  $CO_2$  to a limit of 100 ppm and the catalyst-FID to detect  $CH_4$ , CO,  $CO_2$ , and  $C_2$  to  $C_6$  hydrocarbons to a level of 0.1 ppm.

## Introduction

Carbon dioxide is considered an important heat-trapping greenhouse gas that is released into the atmosphere through several mechanisms, including human activities such as deforestation and burning of fossil fuels, as well as natural processes such as respiration and volcanic eruptions.<sup>1</sup>

The increase in carbon dioxide has spurred innovative decarbonization strategies and carbon dioxide use technologies to offset the amount of carbon dioxide released into the atmosphere. Academic, government, corporate, and private organizations have begun to see CO<sub>2</sub> as a potential renewable feedstock for other chemical products and sources of energy. Biological systems have perfected control of the carbon cycle by controlling the carbon oxidation state for the means of metabolism and production of functionalized carbon-based molecules.

To control the build-up of carbon in the atmosphere, research is continuing to advance the design of these systems to complete the carbon cycle on an industrial scale, resulting in the production of useful compounds for manufacturing and fuel.<sup>2</sup> The process of catalyzed electrochemical reduction of CO<sub>2</sub> using noncarbon-based energy sources, such as photovoltaic and wind, has been a rapidly expanding area of research on CO<sub>2</sub> use technology. With this research comes the need for systems to analyze and optimize the products of such processes. Agilent has developed a multidimensional gas chromatograph that allows researchers in the field to analyze CO<sub>2</sub> reduction byproducts with great accuracy and resolution across a large concentration range. This enables analysis of hydrogen, oxygen, nitrogen, methane, carbon monoxide, carbon dioxide, and C<sub>1</sub> through C<sub>6</sub> hydrocarbons.

## Instrument design

The GC in Figure 1 is designed to handle gas samples that can be delivered by connecting the sample valve directly to a reactor. This allows the reactor pressure to drive the gas sample through the sample loop, or the sample loop can be manually loaded by delivering sample to the loop via a gas tight syringe, fitted with a Luer-lock connected to the *Sample In*.

The gas sample valve is a 10-port valve with a precolumn backflush to vent. It is configured with a 0.5 mL gas sample loop and columns 1 and 2, which are both Agilent HP-PLOT Q PT columns (30 m × 0.53 mm, 40 μm). Column 2 is connected to a 6-port series bypass valve that is configured with an HP-PLOT Molesieve (30 m × 0.53 mm, 50 μm) and a flow balancing capillary restrictor that is sized to match the restriction of the Molesieve column. The 6-port valve flows directly to a thermal conductivity detector (TCD), which is connected

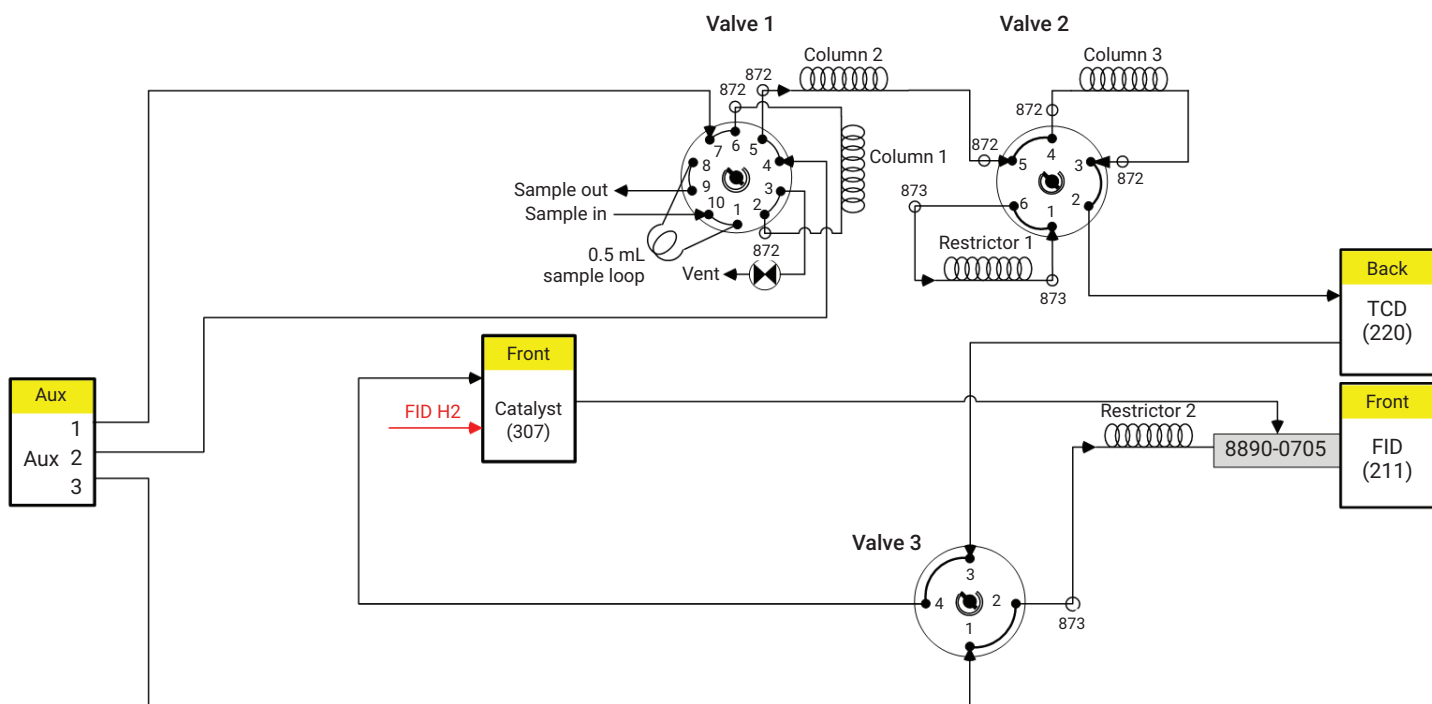

Figure 1. Gas chromatograph plumbing diagram.

to a 4-port selection valve. This valve allows the user to selectively bypass the nickel catalyst and flow directly to the flame ionization detector (FID). The argon carrier gas flow is managed by a single three-channel auxiliary electronic pressure controller.

## Operation

The analysis of catalytic reduction gas is challenging and requires a multidimensional instrument with multiple valves, columns, and detectors, along with nickel catalyst to separate and detect all the necessary components over the full range. A nickel catalyst placed in series with the FID allows the conversion of CO and CO<sub>2</sub> to CH<sub>4</sub> over a range of 0.1 to 1,000 ppm. However, the catalyst has limitations at higher concentrations, therefore a TCD is placed in series in this system, allowing the higher detection ranges from 100 ppm to 100%. This accomplishes a wide range of detection from 0.1 ppm to 100%, which would not be possible on a single-detector system.

The 4-port bypass valve makes the system more robust by providing a selective heart cut of CO and CO<sub>2</sub> through the catalyst, while bypassing all other heavier hydrocarbon components that could limit the life of the catalyst through catalytic coking and poisoning of the catalyst. In this analysis, CO<sub>2</sub> was being reduced at high concentrations near 100%, so the method was designed to bypass CO<sub>2</sub> around the catalyst. In cases where CO<sub>2</sub> analysis is needed below 100 ppm, CO<sub>2</sub> can be routed through the catalyst to allow for low detection down to 0.1 ppm.

## Results and discussion

The chromatograms below show an analysis of reaction products in the range of 100 ppm. Figures 1 and 2 are chromatograms from the TCD and FID, respectively. Upon injection, valve 1 is

GC Hardware	
G3445A	8890 series custom GC
Option 211	Flame ionization detector (FID) with EPC
Option 220	Thermal conductivity detector (TCD) with EPC
Option 301	Auxiliary EPC, provides three channels of auxiliary 0 to 100 psi EPC
Option 305	Factory plumbing for quick installation
Option 306	Exhaust deflector assembly
Option 307	Adds nickel catalyst
Option 503	Gas sampling loop (0.5 cc)
Option 706	Column selection – 6-port valve
Option 763	Heated large valve oven, automated valve box for three valves
Option 801	10-port gas sampling valve
Option 872, Qty 6	Capillary column to valve interface kit, 0.530 mm id
Option 873, Qty 3	Capillary column to valve interface kit, 0.320 mm id
Option 904	Custom plumbing 4-port valve
19095P-Q04PT	Column 1 and column 2: HP-PLOT Q PT, 30 m × 0.53 mm × 40 μm
19095P-MS0E	Column 3: HP-PLOT Molesieve, 30 m × 0.53 mm × 50 μm
160-2205-5	Restrictor 1: fused silica open tube, 0.2 mm × 1.4 m
160-2325-5	Restrictor 2: fused silica open tube, 0.32 mm × 0.45 m
G3188-27501	Flexible metal ferrule, UltiMetal Plus, 0.4 mm id, for 0.1 to 0.25 mm id fused silica tubing
G3188-27502	Flexible metal ferrule, UltiMetal Plus, 0.5 mm id, for 0.32 mm id fused silica tubing
G3188-27503	Flexible metal ferrule, UltiMetal Plus, 0.8 mm id, for 0.53 mm id fused silica tubing
G2855-60200	Ferrule preswaging tool
G2855-20530, Qty 3	Internal nut

switched to the “ON” position, the reactor gas sample passes through column 1 where the sample begins to separate, and H<sub>2</sub>, O<sub>2</sub>, N<sub>2</sub>, CH<sub>4</sub>, CO, CO<sub>2</sub>, and C<sub>2</sub>S are eluted through to column 2. At this point valve 1 is switched to the “OFF” position and hydrocarbons C<sub>2+</sub> and everything

else that remains on column 1, are backflushed to vent.

At the same time, H<sub>2</sub>, O<sub>2</sub>, N<sub>2</sub>, CH<sub>4</sub>, and CO elute through column 2 onto column 3 where they are trapped for later separation. Before CO<sub>2</sub> elutes from column 2, valve 2 is switched to the

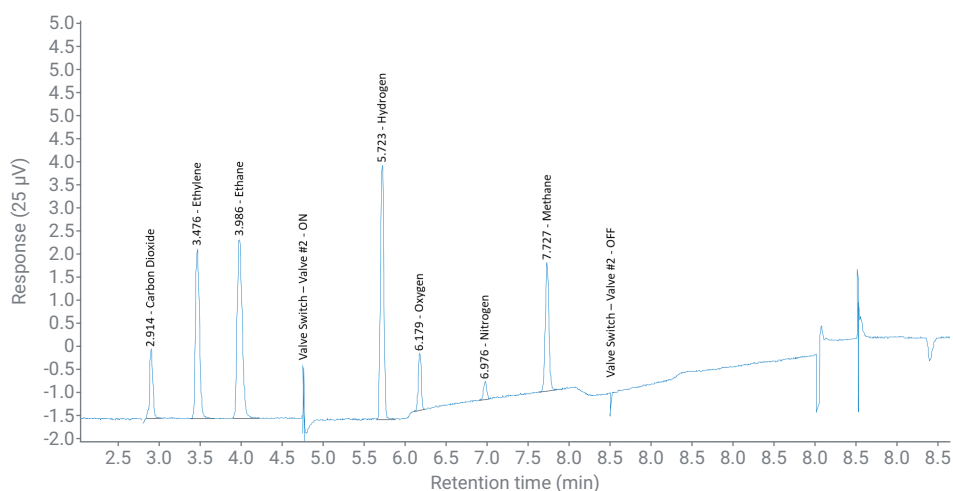

Figure 2. Chromatogram from TCD.

"ON" position and column 3 is bypassed allowing CO<sub>2</sub> and C<sub>2</sub>S to finish eluting from column 2. This bypass is necessary since column 2, the Moleseive column, is too retentive to elute CO<sub>2</sub> and C<sub>2</sub>, which are fully resolved on column 2. These components elute from column 2 and flow through both the TCD and FID, bypassing the catalyst. If low level CO<sub>2</sub> is needed, the heart-cut of CO<sub>2</sub> through the catalyst for low-level detection by FID is also an option.

Once elution of C<sub>2</sub>S is complete, valve 2 is turned back to the "OFF" position and elution of the lighter permanent gases is completed. H<sub>2</sub>, O<sub>2</sub>, N<sub>2</sub>, and CH<sub>4</sub> resolve first and are eluted through the TCD and bypass the catalyst to the FID. Once methane has eluted, CO is selectively cut to the catalyst and detected as methane by the FID. In this example, CO was not detected on the TCD since it was below the TCD detection limits. However, the sensitivity of CO and CO<sub>2</sub> is greatly reduced by the ability to selectively heart-cut through the catalyst and allowing conversion to methane for detection by FID.

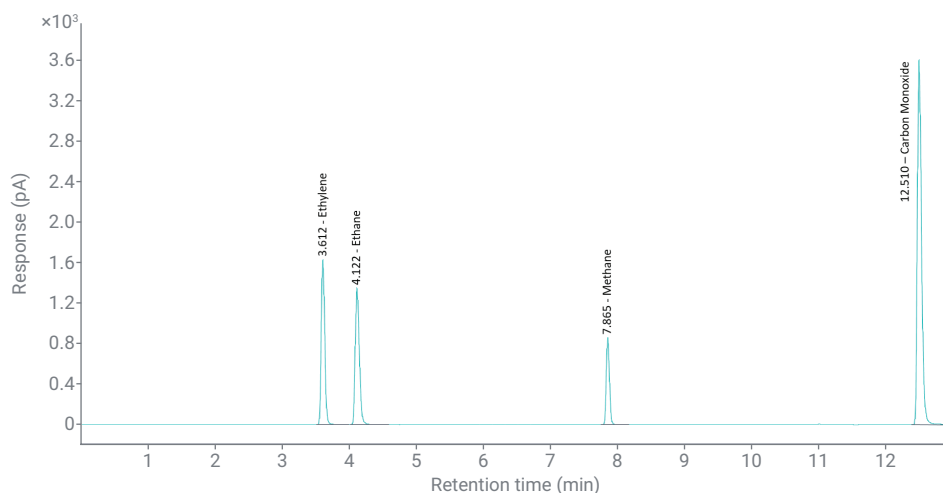

Figure 3. Chromatogram from FID.

## Conclusion

This GC design has proven useful for analyzing gas products from CO<sub>2</sub> reduction reactors in academic research and industrial R&D labs around the globe. These technologies require an expanded detection range of analysis that is beyond the dynamic range of a single detector. By using selective heart-cutting and catalytic reduction of CO and CO<sub>2</sub>, this GC configuration can meet these requirements. The system is capable of analyzing H<sub>2</sub>, O<sub>2</sub>, N<sub>2</sub>, CH<sub>4</sub>, CO, CO<sub>2</sub>, and C<sub>2</sub> to C<sub>6</sub> hydrocarbons.

## References

1. Shaftel, H. NASA Global Climate Change Vital Signs of the Planet. <https://climate.nasa.gov/vital-signs/carbon-dioxide> accessed 06-21
2. Nitopi, S. *et al.* Progress and Perspectives of Electrochemical CO<sub>2</sub> Reduction on Copper in Aqueous Electrolyte. *American Chemical Society* **2019**, 119, 7610–7672.

[www.agilent.com/chem](http://www.agilent.com/chem)

DE94760129

RA44152.6423148148

This information is subject to change without notice.

© Agilent Technologies, Inc. 2022  
Printed in the USA, January 13, 2022  
5994-4524EN