

Electrochemistry of microelectrodes: a comparison with common-size electrodes

A way to overcome diffusion limitations in electrochemical experiments

Summary

In this Application Note, the electrochemical properties of electrodes with a micrometer-size surface area are compared with the electrochemical properties of electrodes with millimeter-size surface area.

The comparison is made through cyclic voltammetry in a $\text{Fe}^{3+}/\text{Fe}^{2+}$ (ferro/ferri) solution, and the differences in the voltammograms are explained with the different diffusion profiles at the electrode-electrolyte interfaces

Configuration



3500001080 - VIONIC

VIONIC is our new-generation potentiostat/galvanostat that is powered by Autolab's new INTELLO software. VIONIC offers the most versatile combined specifications of any single instrument currently on the market. Compliance voltage: ± 50 V; Standard current ± 6 A; EIS frequency: up to 10 MHz; Sampling interval: down to $1 \mu\text{s}$; Also included in VIONIC's price are features that would usually carry an additional cost with most other instruments such as: Electrochemical Impedance Spectroscopy (EIS); Selectable Floating; Second Sense (S2); Analog Scan;

Introduction

Microelectrodes are electrodes with at least one dimension small enough that the properties at the electrode-electrolyte interface are a function of size. Microelectrode surfaces can have different shapes such as spherical, hemispherical, disk, wire, linear and ring. In this Application Note, the focus is on disk microelectrodes, also known as microdiscs, with a surface area in the order of square micrometers (μm^2). In comparison, macroelectrodes have a planar surface on the order of square millimeters (mm^2) or more.

The difference in surface area between macroelectrodes and microelectrodes causes differences in diffusion profiles of electroactive species from the bulk electrolyte to the electrode-electrolyte interface. In macroelectrodes, the planar surface leads to a semi-infinite diffusion field (**Figure 1, top**). In microelectrodes with a disk surface, however, the diffusion field is hemispherical (**Figure 1, bottom**).

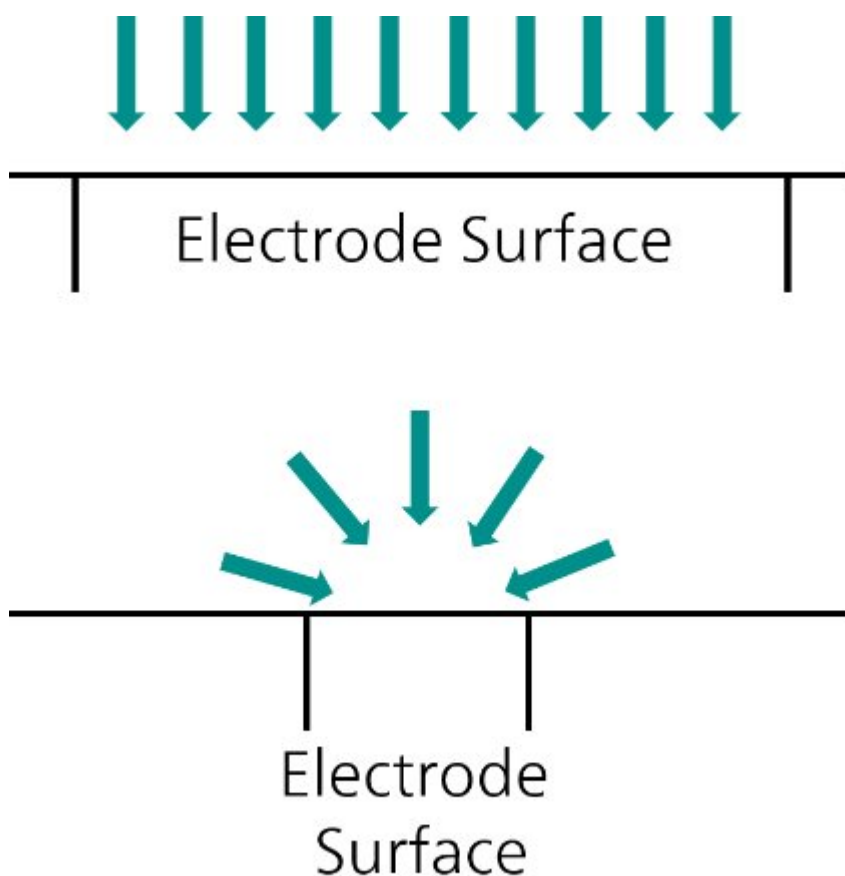

Figure 1. Illustrations of the diffusion profile (green arrows) of electroactive species. Top: the planar diffusion profile from a macroelectrode. Bottom: the hemispherical diffusion profile from a micro size disk electrode.

The different diffusion profiles are responsible for the differences in electrochemical behavior of the microelectrodes compared to macroelectrodes, as shown in the Results section.

The current measured at microelectrodes typically ranges from pA to nA, i.e., orders of magnitude smaller than the current measured at macroelectrodes. The small currents observed at microelectrodes reduce or eliminate the ohmic drop (ΔE_{ohmic}) defined as the product of the current (i) and the electrolyte resistance between the reference and working electrode, called uncompensated resistance (R_u).

$$\Delta E_{ohmic} = iR_u$$

The ability of microelectrodes to reduce or eliminate the ohmic drop allows researchers to perform experiments in highly resistive environments which are unable to be investigated with macroelectrodes (e.g., nonpolar solvents, supercritical fluids, and solids) [1].

Microelectrodes are used in several areas: in analytical electrochemistry due to the increase in the sensitivity of anodic stripping voltammetry, in fundamental electrochemistry to investigate rapid electron transfer and coupled chemical reactions, and in applications investigating reactions with low conductivity electrolytes. Their small surface area is also beneficial in sensor research and in medicinal and biological research [2].

In general, due to the low current measured, the use of a Faraday cage could be required to lower the environmental noise and improve the signal-to-noise ratio of the measured electrochemical signals. Besides, employing sub-nanoamp current ranges could be helpful to increase the current resolution.

Electrochemical measurements performed with microelectrodes require special attention to check for impurities in the system. Small amounts of impurities on the surface could block a significant part of the electroactive surface, changing the electrochemical response of the measured system.

Experimental setup

The experiments consisted of cyclic voltammetry (CV) with two cycles per experiment: from open circuit potential (OCP) to +0.5 V, then to -0.5 V, and back to OCP. The scan rate was 100 mV/s with a step height of 2.44 mV. All the mentioned potentials are referred versus OCP.

As working electrodes, a gold (Au) 3 mm diameter disk electrode (surface area approximately 0.07 cm²) and a gold (Au) 10 μm diameter microelectrode (7.85E-7 cm², or 78.5 μm² surface area) were employed. A Metrohm Pt sheet counter electrode and a Metrohm Ag/AgCl 3 mol/L KCl reference electrode completed the electrochemical cell.

The electrolyte was an aqueous solution of sodium hydroxide (NaOH) 0.1 mol/L, with 0.05 mol/L potassium ferrocyanide (K₄[Fe(CN)₆] or Fe²⁺) and 0.05 mol/L potassium ferricyanide (K₃[Fe(CN)₆] or Fe³⁺).

Fe²⁺ and Fe³⁺ are the active species undergoing reduction/oxidation. Ultrapure water (UPW) was used for the experiments.

Prior to beginning the experiments, the working electrodes were polished with aluminum oxide powder (grain size 0.3 μm), then rinsed with UPW.

The microelectrode was further electrochemically cleaned by performing 100 repeats of cyclic voltammetry in sulfuric acid (H₂SO₄) 0.5 mol/L, between -1 V and +1.5 V, with a scan rate of 1 V/s. All the mentioned potentials are referred versus OCP. Counter and reference electrodes were a Metrohm Pt sheet and a Metrohm Ag/AgCl 3 mol/L KCl, respectively.

For the experiments, VIONIC powered by INTELLO was used (**Figure 2**).



Figure 2. VIONIC powered by INTELLO.

Results and discussion

The following plots show the second cycle of the CV results.

Figure 3 shows the cyclic voltammogram related to the 3 mm diameter gold electrode.

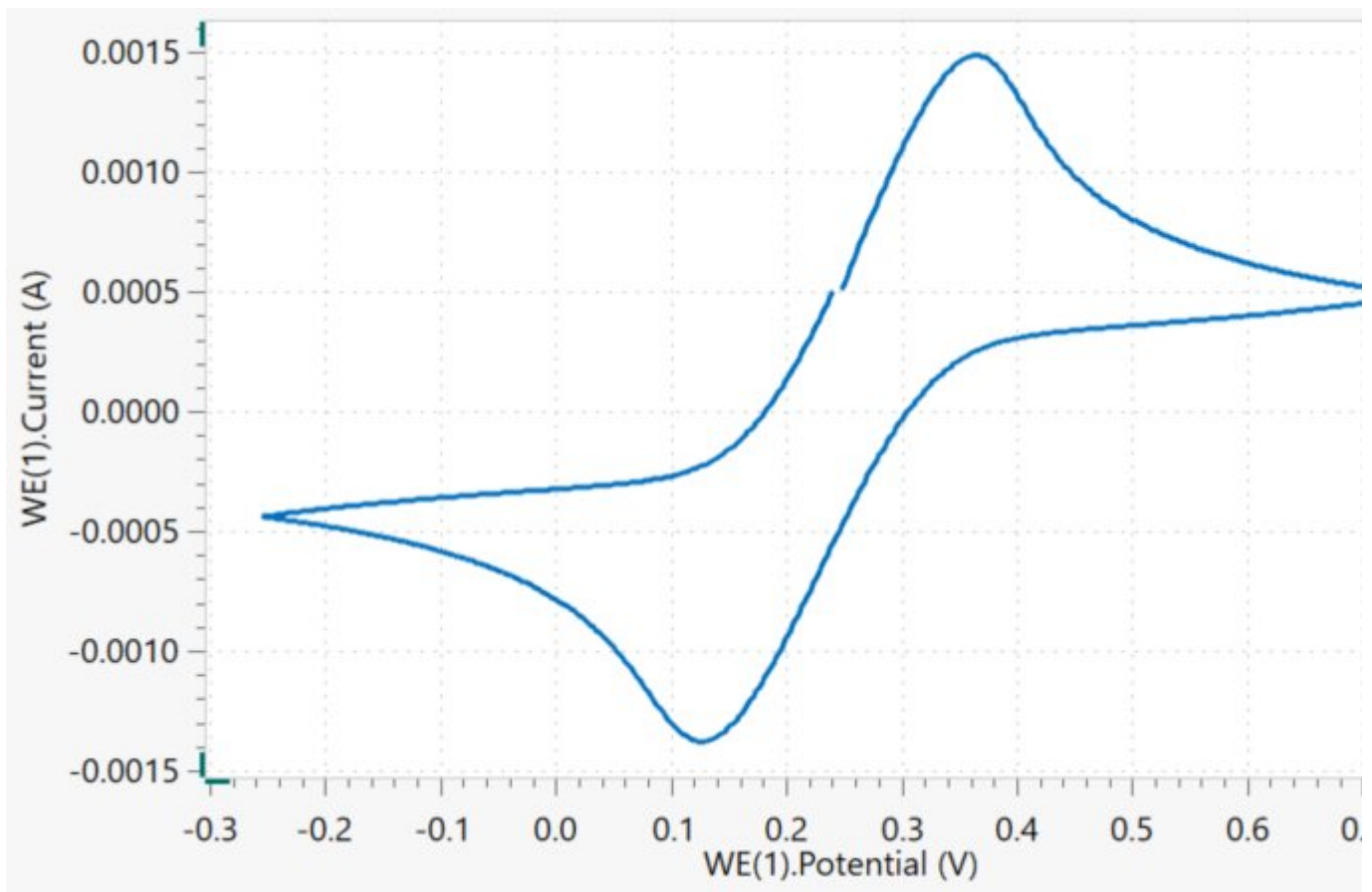
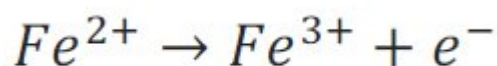

Figure 3. The cyclic voltammogram of a ferri/ferro solution at 100 mV/s with a 3 mm diameter gold electrode.

When the potential is biased to values higher than OCP, the Fe^{2+} ions at the interface are oxidized into Fe^{3+} .



The charge transfer responsible for the oxidation continues increasing, as well as the resulting anodic (positive) current. The oxidation continues until the charge transfer is limited by the mass transport of the Fe^{2+} to the electrode surface, resulting in a decrease of current, as shown between +0.35 V to +0.75 V, with a current peak at approximately +0.35 V.

Similar considerations can be considered for the reduction of the Fe^{3+} ions to Fe^{2+} when the potential is biased to lower values than the OCP.

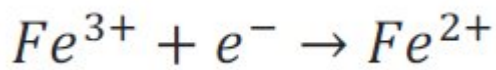

In this case, the charge transfer responsible for the reduction continues increasing, as well as the resulting cathodic (negative) current. The current continues to increase until the charge transfer is limited by the mass transport of the Fe^{3+} to the electrode surface, resulting in a decrease of the negative current, as shown between +0.12 V to -0.35 V, with a negative current peak at about +0.12 V.

The cyclic voltammogram related to the 10 μm diameter gold electrode is shown in **Figure 4**.

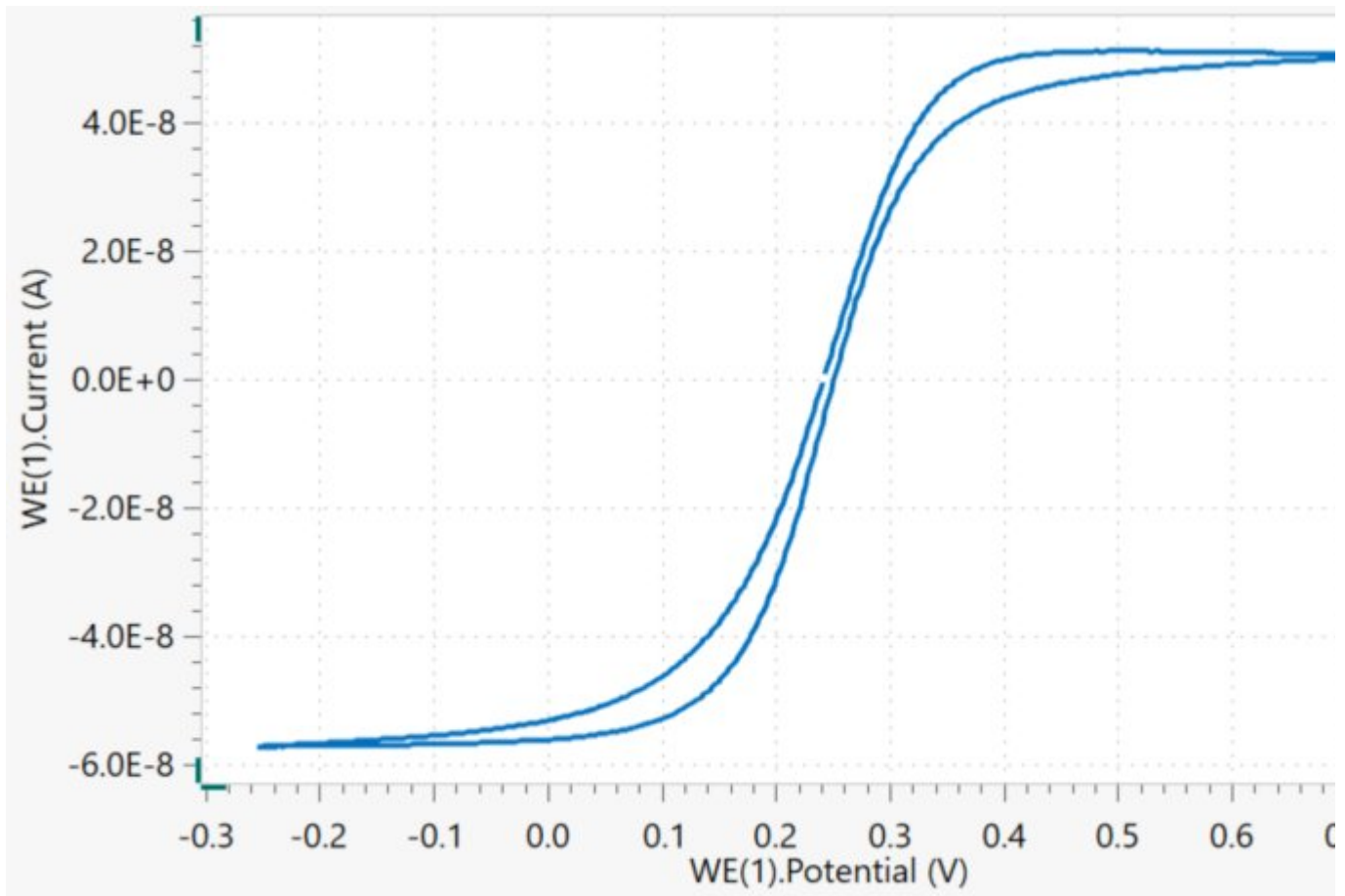

Figure 4. The cyclic voltammogram of a ferri/ferro solution at 100 mV/s with a 10 μm diameter gold electrode.

During the oxidation and reduction process, the Fe^{2+} and Fe^{3+} ions have an **enhanced mass transport** with a stationary hemispheric diffusion profile (**Figure 1**) toward the microelectrode surface. Therefore, the anodic current increases and the cathodic (negative current decreases, respectively, until a limiting value is reached. This is the reason that the

oxidation and reduction peaks (which can be observed for macroelectrodes, **Figure 3**) are not present in the cyclic voltammogram shown in **Figure 4**. These currents are called «limiting currents» and are given by the equilibrium between the charge transfer and the mass transport.

It is also worth noticing the large difference of the measured currents between the macroelectrodes (peak currents at ± 1.5 mA) and microelectrodes (limiting currents at ± 50 nA) due to the large difference in surface area between the two electrode types.

Conclusion

In this Application Note, the electrochemical response of two working electrodes with different surface area is compared. Two gold disk electrodes (diameters of 3 mm and 10 μm) are employed with cyclic voltammetry on a $\text{Fe}^{3+}/\text{Fe}^{2+}$ solution. The difference in the cyclic voltammograms is ascribed to the different diffusion profiles at the electrode–electrolyte interface. In the case of the 3 mm diameter gold disk electrode, the reaction is first controlled by charge transfer kinetics, then limited by mass transport. In the case of the 10 μm diameter gold disk electrode, the reaction is controlled only by the reaction kinetics, with the current increasing, until an equilibrium between charge transfer and mass transport is reached, leading to a current plateau (i.e., «limiting current»).

Bibliography

1. Robert J. Forster. Microelectrodes: New Dimensions in Electrochemistry. *Chem. Soc. Rev. RSC Publ.* **1994**, No. 4, 289–297. <https://doi.org/10.1039/CS9942300289>.
2. Derek Plechter. Why Microelectrodes? *Microelectrodes Theory Appl.* **1991**, 3–16.

Metrohm Česká republika s.r.o.

Na Harfě 935/5c
190 00 Praha

office@metrohm.cz
tel:+420 246 063 433