

Operating principle of medium pressure flow controller that allows catalyst screening at varied pressures

[Background] For screening catalysts, it is important to examine the experimental factors which affect the catalytic reactions. Reaction temperature and pressure are two of the most important factors that determine the conversion and selectivity in reactions with a catalyst. It is essential that both factors are independently controlled to obtain optimum reaction condition. When using the Tandem μ-Reactor (Rx-3050TR) for catalyst screening, the reaction temperature is easily controlled, and several temperature-control modes can be selected. However, changing the reaction pressure leads to the change in the column head pressure, because the reactor is directly connected to the GC injection port. Thus, the high reactor pressure directly relates to a high column flow rate, which results in the deteriorated chromatographic separation and lowering the vacuum of a mass detector. This troublesome feature can be eliminated when a medium pressure flow controller (MP-3050FC) is added to the system, and its outline is described below.

[Operating mechanism] Figure 1 shows a diagram of a Tandem μ-Reactor system with an integrated medium-pressure flow controller. The medium pressure flow controller consists of a flow controller, a back-pressure control valve, a restrictor tube, and an Open-Split Interface. The reaction pressure is controlled by the flow controller (EPC, AFC, etc.) installed in the GC pneumatics, and the column head pressure is controlled by the back-pressure control valve of the medium pressure flow controller. When the reactor pressure is changed in the range of 0.3 to 0.98 MPa, the column flow rate stays constant; thus, characterizations can be performed at user selected column head pressures.

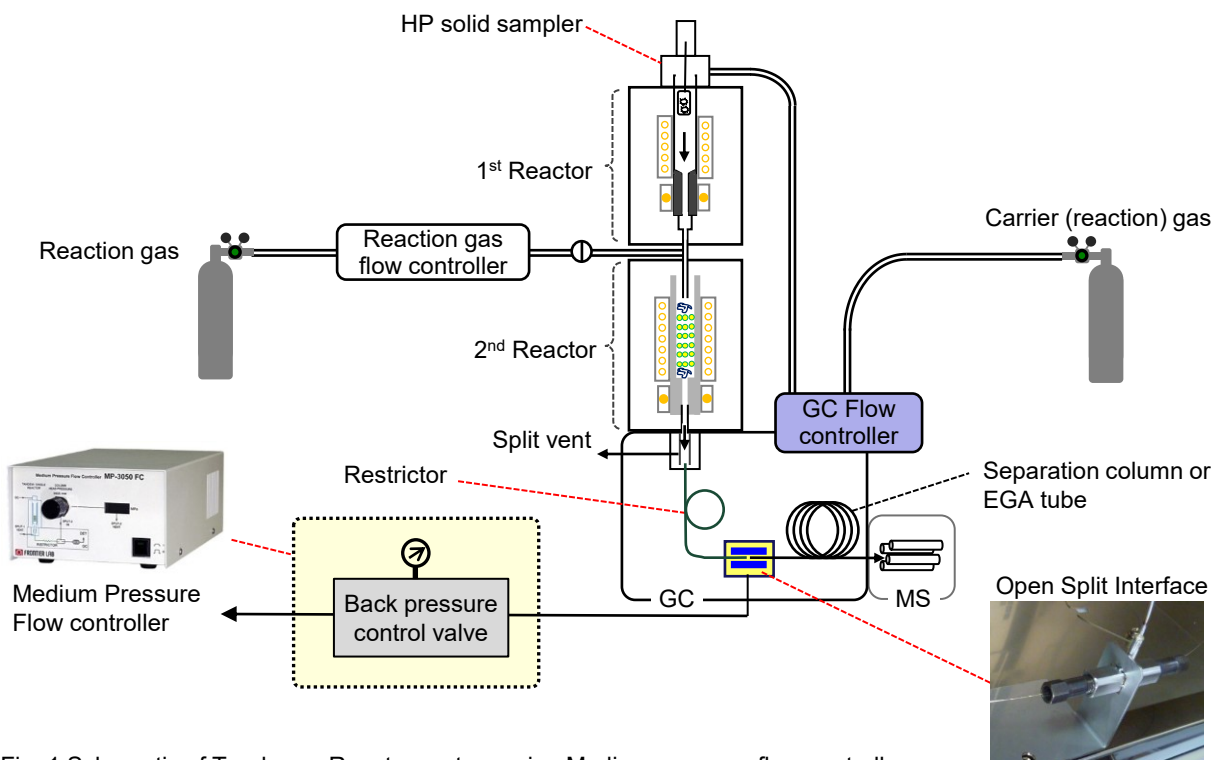

Fig. 1 Schematic of Tandem μ-Reactor system using Medium pressure flow controller

Medium pressure flow controller brochure https://www.frontier-lab.com/assets/file/catalogue/MP-3050FC_E.pdf

Keywords : Catalyst screening

Products used : Tandem μ-Reactor, Single μ-Reactor, Medium pressure flow controller

Applications : Catalyst screening, Catalyst evaluation

Related technical notes : [RXT-001E](#), [RXA-007E](#)

Please forward your inquiries via our web page or send us a fax message.

R&D and manufactured by :
Frontier Laboratories Ltd.

Phone: (81)24-935-5100 Fax: (81)24-935-5102
<http://www.frontier-lab.com/>