

# MS Table (All Models)

User Manual

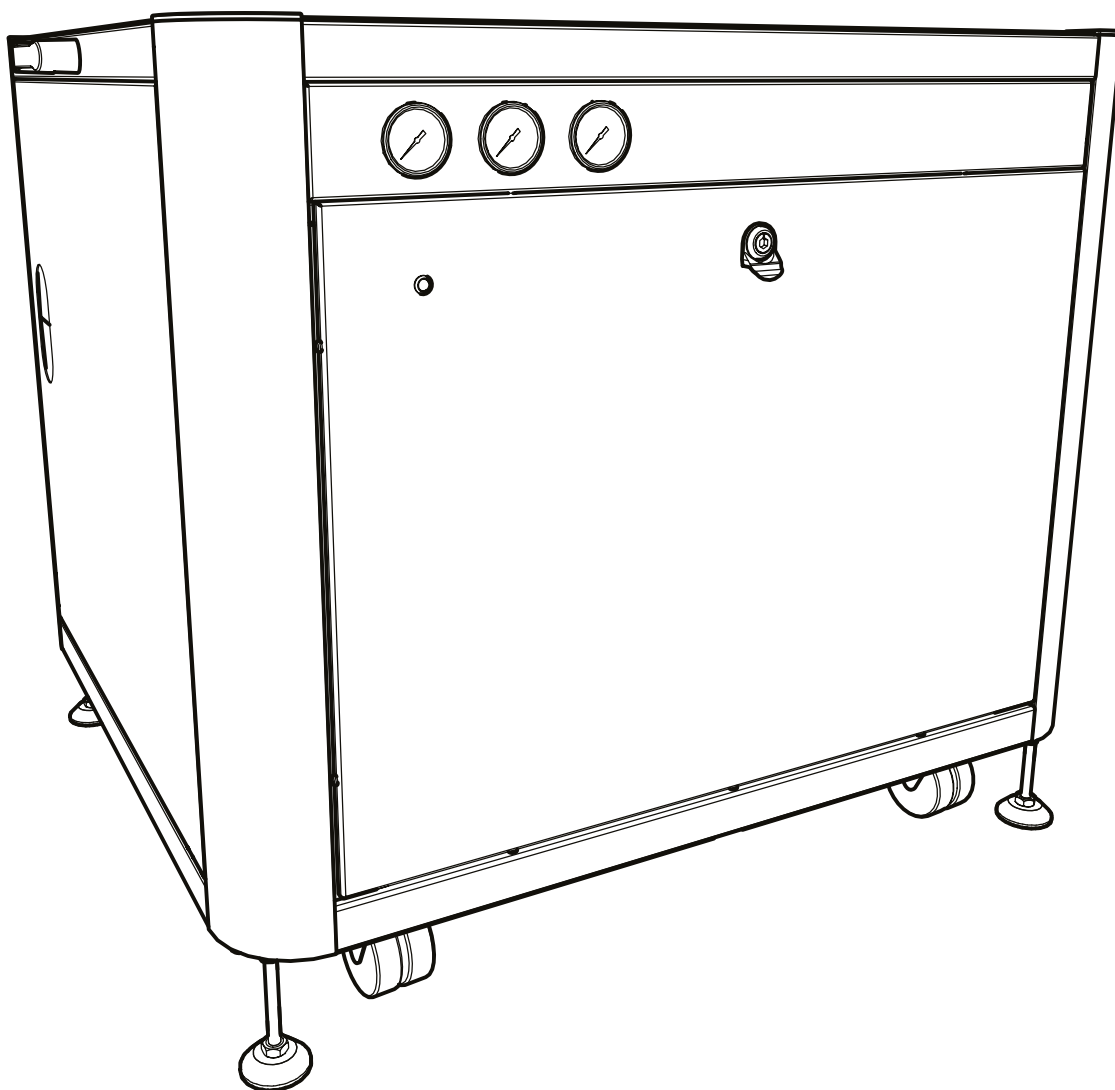

# Contents

Change History	3
How to use this Manual	3
Introduction	4
Warranties and Liabilities	5
Safety Notices	6
Symbols	6
Safety Notice to Users	6
Declaration of Conformity	7
Environmental Declaration	8
Technical Specification	9
Technical Specification	10
Fittings Kit Contents	12
Unpacking Instructions	12
Installation	13
Generator Environment	13
Generator Overview	14
1.5L & 3.5L General Dimensions	14
Rear Connections	15
Drain Connection	15
Electrical Connection	16
Air Connection	17
Air Purity	17
Class 1 Particulate	17
Class 4 Water	17
Class 1 Oil	17
Connecting to the application	18
Tubing Lengths	18
Normal Operation	19
Unusual Operation	19
Relocation of MS Table	19
Fan Power LED	19
Safe Operation of Pump Tray	20
Infinity 1031 Installation	21
Service Requirements	22
Service Schedule	22
Peak Protected	23
Cleaning	24
Troubleshooting	25

## Change History

<b>Rev</b>	<b>Comment</b>	<b>Name</b>	<b>Date</b>
Rev 1	Update flow rates	David Lai	25 Aug 2017

## How to use this Manual

This manual is intended for end users and has been written as a reference document where you can skip to the relevant information.

Users can refer to the contents page to find the relevant information.

Please review each of the following sections carefully.

Thank you for selecting Peak Scientific to meet your gas generation needs, and should you require any further assistance or support please do not hesitate to contact Peak Scientific or the Peak Partner from which you purchased your generator.

# Introduction

The MS table has been designed as a Sciex exclusive product to house the Triple Quad™, QTRAP™ or IVD MS systems. The MS table comes in a standard and premium form, the premium version including an inbuilt Infinity 1031 allowing the supply of curtain, source and exhaust gases. Furthermore, the MS Table also functions as an accessible sound proof enclosure for the required vacuum pumps for these applications.

Other features include:

- Table designed to hold Sciex Mass Spectrometer
- Can be supplied on its own or with an integrated Infinity 1031 compressor-less nitrogen generator
- Reduced lab footprint
- Minimal set-up required
- Sound proofed, reducing noise of generator

To ensure these generator models meet our high expectations with regards to reliability and performance, we have tested them extensively at our manufacturing plant and with end users around the world to ensure reliability and longevity of the system.

## Warranties and Liabilities



1. The Company warrants that it has title to the Goods.
2. Subject to the provisions of this clause the Company warrants that the Goods shall comply in all material respects with any specification referred to in the Order Confirmation (as the same may be amended) and shall, subject thereto, be free from defects in material and workmanship for the lesser of a period of twelve months from the date of delivery or thirteen months from the date of dispatch from the factory.
3. Save as provided in this clause and except where the Goods are sold to a person dealing as a consumer (within the meaning of the Unfair Contract Terms Act 1977) all warranties, conditions or other terms implied by statute or common law are hereby expressly excluded save to the extent they may not be lawfully excluded. When the Goods are sold to a consumer within the meaning of the Unfair Contract Terms Act 1977 their statutory rights are not affected by the provisions of this clause.
4. In the event of the Customer making a claim in respect of any defect in terms of clause 2 hereof the Customer must.
  1. Reasonably satisfy the Company that the Goods have been properly installed, commissioned, stored, serviced and used and without prejudice to the generality of the foregoing that any defect is not the direct or indirect result of lack of repair and/or servicing, incorrect repair and/or servicing, use of wrong materials and/or incorrect spare parts
  2. Allow the company to inspect the Goods and/or any installation and any relevant packaging as and when reasonably required by the Company.
5. Subject to the Company being notified of any defect as is referred to in sub-clause 2 hereof within a reasonable time of it becoming apparent and subject always to the terms of sub-clause 4 hereof, the Company shall, in its option, replace or repair the defective Goods or refund a proportionate part of the Price. The Company shall have no further liability to the Customer (save as mentioned in sub-clause 6 hereof).
6. The Company shall be liable to indemnify the Customer in respect of any claim for death or personal injury to any person in so far as such is attributable to the negligence or breach of duty of the Company or any failure by the Company to comply with the provisions of sub-clause 2 hereof.
7. Save as provided in sub-clause 2 hereof the Company shall not be liable in respect of any claim by the Customer for costs, damages, loss or expenses (whether direct, indirect, consequential or otherwise) or indemnity in any respect howsoever arising including, but not by way of limitation, liability arising in negligence (other than pursuant to clause 6 above) that may be suffered by the Customer or any third party.

# Safety Notices

Peak Scientific Instruments cannot anticipate every possible circumstance which may represent a potential hazard. The warnings detailed within this manual refer to the most likely potential hazards, but by definition cannot be all inclusive. If the user employs an operating procedure, item of equipment or a method of working which is not specifically recommended by Peak Scientific, the user must ensure that the equipment will not be damaged or become hazardous to persons or property.

## Symbols

This manual uses the following symbols to highlight specific areas important to the safe and proper use of the generator.

 <p>WARNING</p>	<p>A WARNING notice denotes a hazard. It calls attention to an operating procedure, process or similar, which if not correctly performed or adhered to, could cause personal injury or in the worst case death. Do not proceed beyond a WARNING notice until the indicated conditions are fully understood or met.</p>
 <p>CAUTION</p>	<p>A CAUTION notice denotes a hazard. It calls attention to an operating procedure, process or similar, which if not correctly performed or adhered to, could cause damage to the generator or the application. Do not proceed beyond a CAUTION notice until the indicated conditions are fully understood or met.</p>
	<p>Caution, risk of electric shock. Ensure power to the generator has been removed before proceeding.</p>

## Safety Notice to Users



These instructions must be read thoroughly and understood before installation and operation of your Peak Generator. Use of the generator in a manner not specified by Peak Scientific MAY impair the SAFETY provided by the equipment.



When handling, operating or carrying out any maintenance, personnel must employ safe engineering practices and observe all relevant local health and safety requirements and regulations. The attention of UK users is drawn to the Health and Safety at Work Act 1974, and the Institute of Electrical Engineers regulations.



If the equipment is used in a manner not specified by the manufacturer, the protection provided by the equipment maybe impaired.

# Declaration of Conformity

We Peak Scientific Instruments Ltd.  
Of Fountain Crescent, Inchinnan, Renfrewshire, PA4 9RE

Declare that:

Equipment: Nitrogen Gas Generator  
Models: MS Table

To which this declaration relates, is in conformity with the applicable EC directives, harmonized standards, and other normative requirements.

- **Low Voltage Directive 2014/35/EU**  
EN 61010-1: 2010 Electrical Equipment for measurement, control and laboratory use.  
  
CAN/CSA-C22.2 No. 61010-1-04 Safety requirements for Electrical Equipment for Measurement, Control and Laboratory use, Part 1: General requirement.
- **Electromagnetic Compatibility Directive 2014/30/EU**  
EN 61326-1: 2013 Electrical Equipment for measurement, control and laboratory use.
- **FCC47 CFR Part 15 Class B**  
Unintentional radiators; Conducted and Radiated emissions limits.

All evaluation, testing and certification issued by:

**Nemko Canada Inc.**  
303 River Road,  
Ottawa  
Ontario  
Canada  
K1V 1H2

**TUV Product Service LTD.**  
Octagon House, Concorde Way  
Segenworth North, Fareham  
Hampshire  
England  
PO15 5RL

Signed:  Name: Chris Pugh

Date: 03/02/2017 Position: Chief Technology Officer



# Environmental Declaration

We Peak Scientific Instruments Ltd.  
Of Fountain Crescent, Inchinnan, Renfrewshire, PA4 9RE

Declare that:

Equipment: Nitrogen Gas Generator

Models: MS Table

Is fully compliant with the following Directives

- 2012/19/EU WEEE (Waste of Electrical and Electronic Equipment)
- 2011/65/EU RoHS 2 (Restriction of Hazardous Substance)

Peak Scientific Instruments Ltd fully complies with its obligations towards the European WEEE (Waste of Electrical and Electronic Equipment) Directive 2012/19/EU. These obligations are being met within the B2B compliance group.

Peak Scientific Instruments Ltd has developed all reasonable 'due diligence' controls to ensure that our products comply with the principles and requirements of the European recast RoHS (Restriction of Hazardous Substances) Directive 2011/65/EU. Similar directives in the United States and China, for example, have also been captured within this program.

Where a specific certificate of compliance is required, this can be requested, on a product serial number basis, directly from Peak Scientific Instruments Ltd, by contacting us through our website on [www.peakscientific.com](http://www.peakscientific.com)

Signed:  Name: Chris Pugh

Date: 16/01/2012 Position: Chief Technology Officer





# Technical Specification

## Environment

	1B	1N
Minimum Operating Ambient Temperature	5°C (41°F)	
Maximum Operating Ambient Temperature	30°C (86°F)	
Maximum Altitude	2000 meters	
Maximum Relative Humidity	70% Non-Condensing	
Minimum Storage Temperature*	-20°C (-4°F)	
Maximum Storage Temperature*	60°C (140°F)	

## Inlet Conditions

Maximum Inlet Air Pressure	N/A	8.3-10 bar (120-145 psi)
Minimum Air Inlet Flow	N/A	115 L/min (4.06 cfm)

## Generator Outlets

Curtain Maximum Output Pressure	N/A	4.50 bar (60 psi)
Curtain Maximum Outlet Flow Rate	N/A	19 L/min (0.67 cfm)
Source Maximum Output Pressure	N/A	7.60 bar (110 psi)
Source Maximum Outlet Flow Rate	N/A	26 L/min (0.91 cfm)
Exhaust Maximum Output Pressure	N/A	4.1 bar (60 psi)
Exhaust Maximum Outlet Flow Rate	N/A	25 L/min (0.88 cfm)
Particles	N/A	<0.01µm
Phthalates	N/A	NONE
Suspended Liquids	N/A	NONE
Gas Outlets	N/A	3 x ¼" BSPP
Drain Outlet	N/A	1 x ¼" BSPP
Pressure Gauges	N/A	3
Start-Up Time	N/A	30 minutes

## Electrical Requirements

Voltage	110-240 VAC	
Frequency	50/60 Hz	
Current	1 Amp	
Input Connection	C14	
Power Cord Type	C13	
Pollution Degree	2	
Installation Category	II	

## General

Dimensions cm (inches) WxDxH	100.0 (39.4) x 83.0 (32.6) x 80.4 (31.6)	
Generator Weight Kg (lbs)	100.0 (220.5)	103.5 (229.0)
Shipping Weight Kg (lbs)	132.5 (292.0)	136.0 (300.0)

# Technical Specification

## Environment

	2N Hi-Flow
Minimum Operating Ambient Temperature	5°C (41°F)
Maximum Operating Ambient Temperature	30°C (86°F)
Maximum Altitude	2000 meters
Maximum Relative Humidity	70% Non-Condensing
Minimum Storage Temperature*	-20°C (-4°F)
Maximum Storage Temperature*	60°C (140°F)

## Inlet Conditions

Maximum Inlet Air Pressure	8.3-10 bar (120-145 psi)
Minimum Air Inlet Flow	115 L/min (4.06 cfm)

## Generator Outlets

Curtain Maximum Output Pressure	4.50 bar (65 psi)
Curtain Maximum Outlet Flow Rate	10 L/min (0.35 cfm)
Source Maximum Output Pressure	7.60 bar (110 psi)
Source Maximum Outlet Flow Rate	22 L/min (0.78 cfm)
Exhaust Maximum Output Pressure	4.1 bar (60 psi)
Exhaust Maximum Outlet Flow Rate	10 L/min (0.35 cfm)
Particles	<0.01µm
Phthalates	NONE
Suspended Liquids	NONE
Gas Outlets	3 x ¼" BSPP
Drain Outlet	1 x ¼" BSPP
Pressure Gauges	3
Start-Up Time	30 minutes

## Electrical Requirements

Voltage	110-240 VAC
Frequency	50/60 Hz
Current	1 Amp
Input Connection	C14
Power Cord Type	C13
Pollution Degree	2
Installation Category	II

## General

Dimensions cm (inches) WxDxH	100.0 (39.4) x 83.0 (32.6) x 80.4 (31.6)
Generator Weight Kg (lbs)	108.5 (239.2)
Shipping Weight Kg (lbs)	136.0 (300.0)

# Unpacking

Although Peak Scientific takes every precaution with safe transit and packaging, it is advisable to fully inspect the unit for any sign of transit damage.

Check 'SHOCKWATCH' and 'TIP-N-TELL' labels for signs of rough handling prior to unpacking.

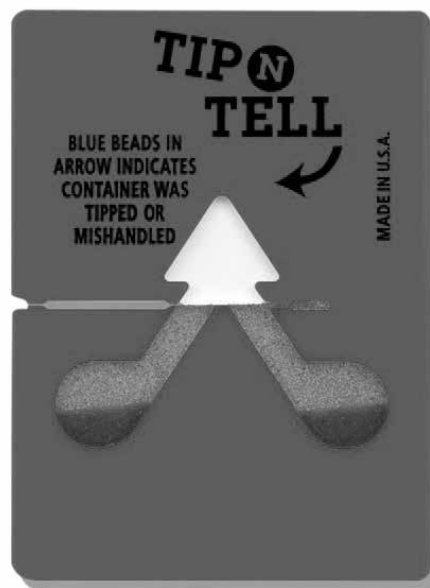

**Any damage should be reported immediately to the carrier and Peak Scientific or the Peak Partner from where the unit was purchased.**

Follow the unpacking instructions posted on the side of the crate. It will require two people to remove the unit from the shipping crate and to manoeuvre the air compressor onto the bench.

Please save the product packaging for storage or future shipment of the generator.

Note: Included with the generator is a "Fittings Kit" containing mains power leads for UK, EU & US and also all the required fittings and warranty registration card. Be careful not to discard these with the packaging.

## Fittings Kit Contents

Supplied in the Fittings Kit are all the fittings required to connect the generator to the application. The contents of the Fittings Kit are as follows:

1. ¼" Teflon Tubing*	x 12m
2. 6mm PE Tubing*	x 3m
3. 8mm Hex Key	x 1
4. UK Mains Power Cable	x 1
5. EU Mains Power Cable	x 1
6. US Mains Power Cable 110v	x 1
7. US Mains Power Cable 230v	x 1
8. M5 Plain Washer	x 6
9. M5 Spring Washer	x 6
10. M5 Screw	x 6
11. 6mm Push-In Plug	x 1

\* included with 1N & 2N Table Variants only

All of the generators output ports are located on the output panel at the rear of the unit.

# Installation

## Generator Environment

The generator is designed for indoor use only. It should be installed adjacent to the application(s) it is supplying. If this is not convenient then the unit can be sited elsewhere, however, consideration should be made of the lengths of pipe runs as pressure drops can result from extended runs of pipe.

Performance of the generator (like all sophisticated equipment) is affected by ambient conditions. Note should also be taken to the proximity of Air Conditioning outlets. These can sometimes give rise to “pockets” of air with high relative humidity. Operation of the unit within such a pocket could adversely affect its performance. Consideration should also be given to the air flow around the unit. It is recommended that an air gap of 75mm (3”) should be maintained down both sides and at the rear of the unit. Please refer to the drawing below for the general dimensions of the unit.

Minimum Operating Ambient Temperature:        5 °C (41 °F)

Maximum Operating Ambient Temperature:        30 °C (86 °F)

# Generator Overview

## General Dimensions

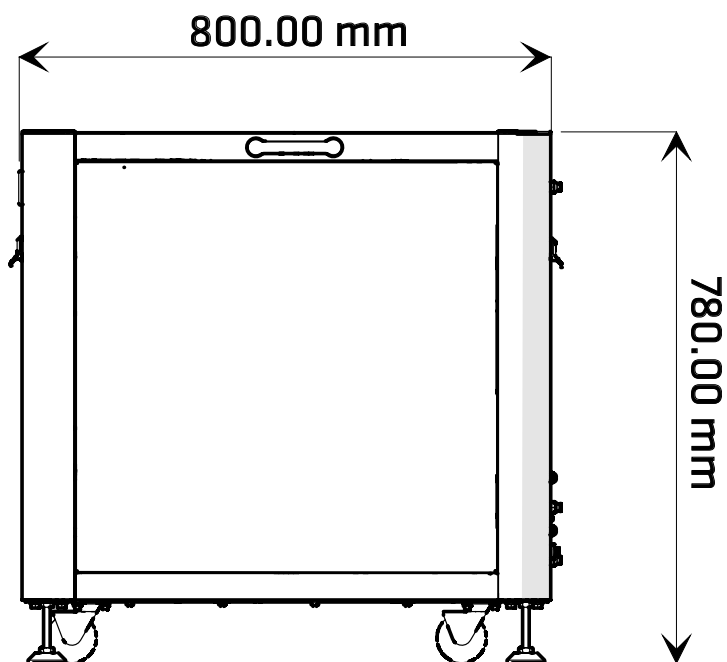
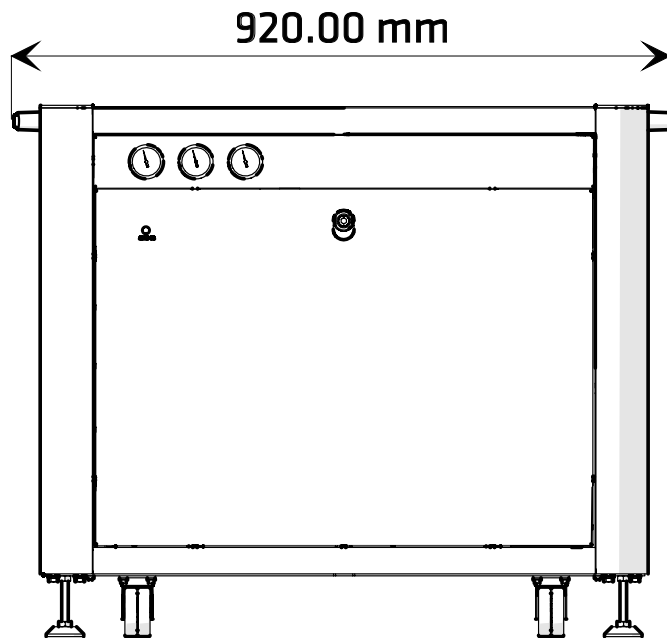

The generator must always be placed on a flat, level surface. Failure to do so will affect the performance of the generator.

# Rear Connections

Supplied in the Fittings Kit are all the fittings required to connect the MS Table Generator to the application. The contents of the Fittings Kit are as follows:

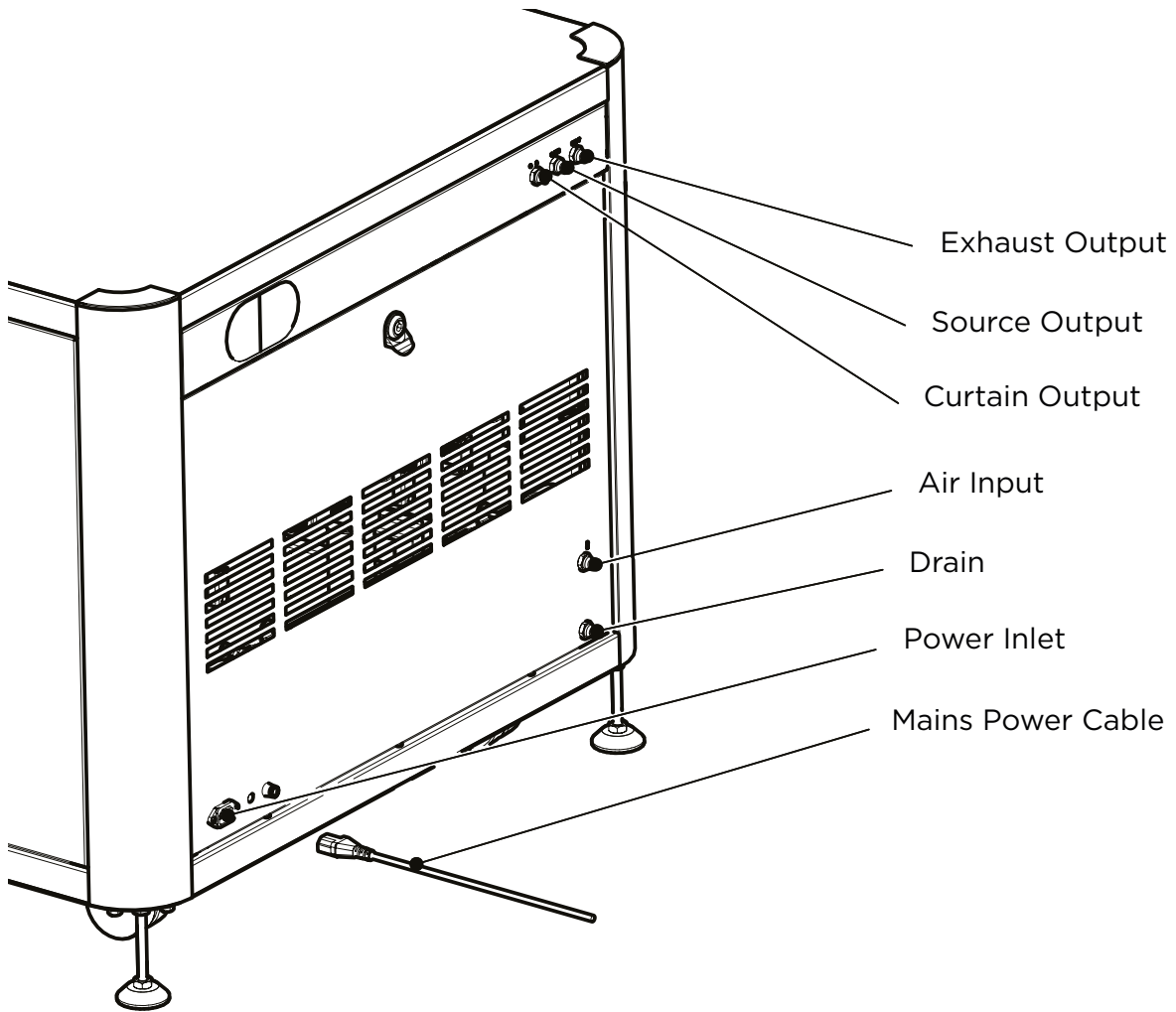

## Drain Connection

For users of the 1N and 2N Hi-Flow, use the ¼” Teflon tubing to connect the drain outlet to a suitable drain connection. It should be noted that the Generator can expel a considerable amount of water from this (dependant on ambient humidity).



If a container is used it should be emptied at regular intervals. The container must NOT have an air tight seal as water and air are expelled at pressure.

# Electrical Connection

Connect the Generator to an appropriate 110 or 230 volt single-phase supply, refer to the generator serial plate for input specification and ensure your supply matches the requirements.

If the appropriate power cord is not supplied; a new plug, rated to at least 13 amps, can be fitted by a qualified electrician.



This unit is classified as SAFETY CLASS 1. THIS UNIT MUST BE EARTHED. Before connecting the unit to the mains supply, please check the information on the serial plate. The mains supply must be of the stated AC voltage and frequency.

EARTH/GROUND (E):-                      Green & Yellow      or      Green

LIVE (L):-                                      Brown                      or      Black

Neutral (N):-                                  Blue                                  or      White

Electrical requirements are 110 or 230VAC nominal +/- 10% depending on chosen model. However, running continuously at voltages outwith this is not recommended. Extended periods at extremes can have a detrimental effect on the operation and life of the Generator.



If the equipment is used in a manner not specified by the manufacturer, the protection provided by the equipment maybe impaired.



## Air Connection

The Table-1N/2N Hi Flow Generator should be connected to a clean, dry, OIL - FREE source of compressed air. A minimum inlet pressure of 120 psig (8.3 barg) is required. Any doubts as to the suitability of your compressed air supply should be referred to Peak Scientific or any of their authorised partners.

The Compressed Air supply should be connected to the inlet located at the rear of the unit as shown in the Rear Connections section of this manual.

## Air Purity

The MS Table generator should be connected to an air supply that, as a minimum, meets ISO8753-1:2010 Class 1.4.1

### Class 1 Particulate

In each cubic metre of compressed air, the particulate count should not exceed 20,000 particles in the 0.1 - 0.5 micron size range, 400 particles in the 0.5 - 1 micron range and 10 particles in the 1 - 5 micron size range.

### Class 4 Water

A pressure dew point (PDP) of +3°C or better is required and no liquid water is allowed.

### Class 1 Oil

In each cubic metre of compressed air, not more than 0.01mg of oil is allowed. This is a total level for liquid oil, oil aerosol and oil vapour.

## Connecting to the application

Once the initial purge run of 30 minutes has completed the generator is now ready to be connected to the application(s).



The pressure in the internal storage tanks must be allowed to dissipate before connecting the generator to the application(s)

Attach the 1/4" compression fitting to the outlet of the generator. Using the 1/4" tubing supplied, connect the outlet of the generator to the inlet on the application.

If you require more tubing than is supplied please refer to the Tubing Lengths section.



Once the tubing is connected to the application, please ensure that it is thoroughly checked for being leak-tight. Even the slightest leak in the gas supply between the generator and the application can lead to a reduction in efficiency.

### Tubing Lengths



The diameter of the tubing which will be connected to the gas outlet is important and is determined by the length of tubing required. Failure to follow these recommendations could lead to pressure between generator and application.

- < 10 meters: Use 1/4"/3/16" (1/4" O/D, 3/16" I/D) P.T.F.E. tubing.
- > 10 - 40 meters: Use 3/8"/5/16" (3/8" O/D, 5/16" I/D). Tubing and fittings not supplied in the fittings kit.
- > 40 metres: Please contact Peak Scientific with the relevant distance and we will calculate the flow resistance and the tubing size required.

A combination of 1/4"/3/16" and 3/8"/5/16" tubing may be used to ensure that there is no large diameter tubing within the lab (i.e. for the first 20 meters from the generator use 3/8"/5/16" and the final 10 meters to the application use 1/4"/3/16" tubing). Keep the connections and bends to a minimum.

## Normal Operation

The MS Table Gas Generator is designed specifically to minimize operator involvement. Given that the system is installed as described in earlier sections and is serviced in accordance with the specified maintenance recommendations (see Service Requirements), then it should simply be a matter of turning the Generator on when it is required.

The Generator will automatically produce the factory set flow and pressure as detailed in the Technical Specifications.

## Unusual Operation

If at any time the generator begins to emit excessive noise or vibration, then it should be switched off and you should contact Peak Scientific or the Peak Partner from which the generator has been purchased.

## Relocation of MS Table

1. Turn off and disconnect power to the generator.
2. Disconnect the Air Connection to the generator.
3. Remove the MS Instrument from on top of the table
4. Disengage the leveling feet.

Once the MS Table has been safely moved to its new location, the MS Table can then be installed as per the Installation Guide.

## Fan Power LED

The MS Table 2N Hi-Flow is fitted with a fan power LED on the front panel.

The LED should be illuminated when the Generator is supplied with power. This is indication that the fans attached to the front panel are being supplied with power, and are running correctly.

The front panel should be connected to the power supply as shown below.

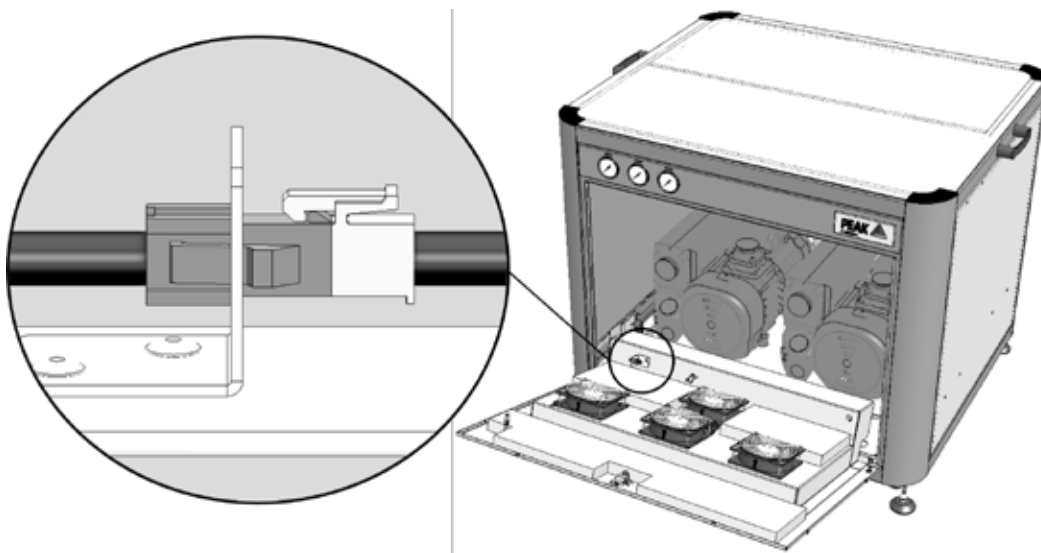

## Safe Operation of Pump Tray

For safe installation or removal of roughing pumps, we recommend use of the sliding function of the pump tray, as shown below.



This should only be attempted once the Mass Spec has been positioned on top of the table.

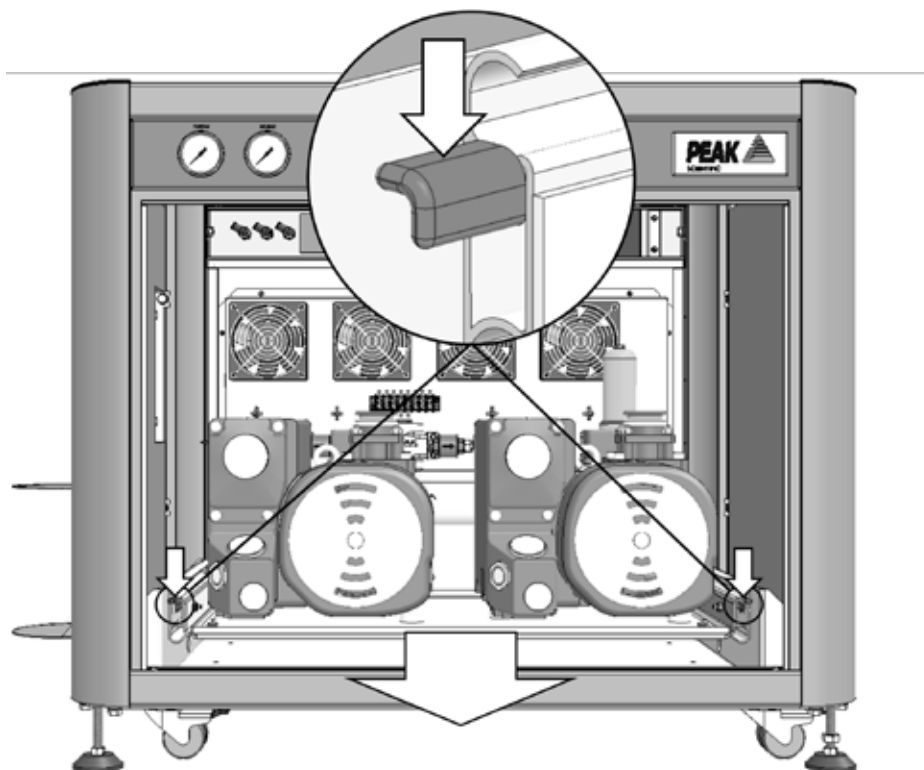

Remove the front panel, ensuring that the fan power and earth cables are disconnected.

Remove earth straps by pulling it off the spade connector on the front panel.

Depress both yellow tabs simultaneously and pull tray outwards until it clicks into position.

Once pumps have been installed, ensure correct reconnection of earth straps and fan power lead.

## Infinity 1031 Installation

The MS Table 1N & 2N Hi-Flow specifically contains an integrated Nitrogen Generator providing a source of High Purity Nitrogen with 2 independent additional outlets of clean dry Zero Grade air.

The MS Table 1B does not have an integrated Nitrogen Generator, but does have the facility to bolt-on to the side of the table a Peak Scientific Instruments Wall Mounted Infinity 1031 Nitrogen Generator.

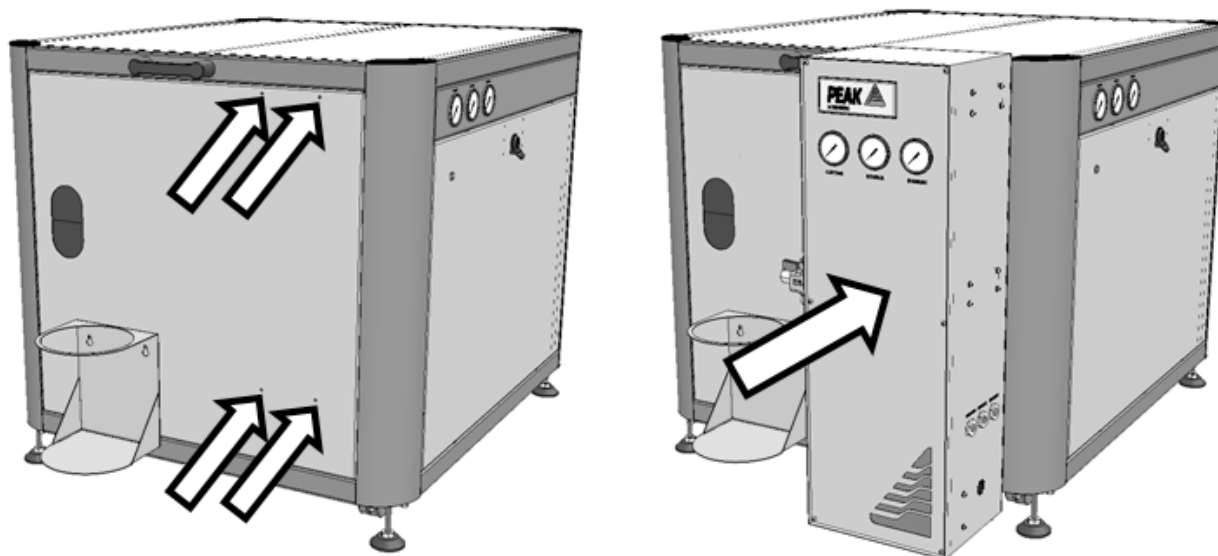

Using the remaining M5 fittings from the fittings kit, mount the Infinity 1031 to the side of the MS Table 1B. Note the front panel of the Infinity 1031 will need to be removed in order to attach the fittings.

# Service Requirements

## Service Schedule

Purchase Interval	Component	Visit
12 Months	Genius MS Table 1N Annual Maintenance Kit	<a href="http://www.peakscientific.com/ordering">www.peakscientific.com/ordering</a>
	Genius MS Table 2N Hi-Flow Annual Maintenance Kit	
	Infinity 1031 Annual Maintenance Kit	

# Peak Protected

With Peak Scientific you invest in not only a product but peace of mind. With a network of certified Peak engineers stationed throughout the globe, Peak's rapid response team are never far away and our commitment is to keep your generator running day in, day out, protecting your laboratory workflow.

## [Peak Protected] can provide...



**Installation**  
A dedicated Peak engineer will visit your lab to install and setup your generator



**Complete plan**  
Swift response by a Peak Service Engineer within 72 hours & planned preventative maintenance



**Premium Protected**  
Guaranteed rapid on-site response within 24 hours & planned preventative maintenance



**IQ/OQ**  
Certified assurance for applications requiring documented qualification

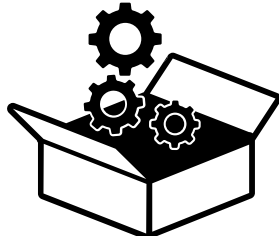

**Spares**  
Genuine Peak parts with express delivery, ensuring optimal performance and lifetime



**Technical Support Hotline**  
Around the clock support by phone or online with our global technical helpdesk

To find out more about protecting your investment visit: [www.peakscientific.com/protected](http://www.peakscientific.com/protected)

# Cleaning

Clean the outside of the generator only using warm soapy water and a clean damp cloth. Ensure all excess fluid is thoroughly removed from the cloth prior to use.



Cleaning should only be undertaken with the power switched off and the power cord removed from the rear of the Generator.





Under no circumstances should any solvents or abrasive cleaning solutions be used as these can contain fumes that could be harmful to the generator.



Care should be taken with Leak Detections Liquids.



# Troubleshooting

Problem	Possible Solution
The green LED has not illuminated but the power switch is illuminated.	<ul style="list-style-type: none"><li>• Contact your service provider.</li></ul> 
The instrument is reporting low pressure.	<ul style="list-style-type: none"><li>• Check for leaks between the generator and instrument.</li><li>• Contact your service provider.</li></ul>
The unit is switched on but the fans are not turning and the LED is not lit.	<ul style="list-style-type: none"><li>• Contact your service provider.</li></ul> 

# Go Online or Complete and Return

We know that registering any of your recently purchased products is not the first thing on your mind- but it is very important to both of us. Not all warranties are alike and Peak Scientific stand out against other gas suppliers as we offer a comprehensive, quick response, on-site warranty. This means that in the very unlikely case that your gas generator develops a fault we have rapid support teams on-hand around the world who are able to come to your lab and get you back up and running in no time.

Register for your **comprehensive 12 month on-site warranty** with ease online at [www.peakscientific.com/protected](http://www.peakscientific.com/protected).

Alternatively, you can send the completed form to Peak Scientific by post or email at [warranty@peakscientific.com](mailto:warranty@peakscientific.com).

**Go Online or Complete and Return**

You can register for your **FREE 12 month Warranty** with ease online at [www.peakscientific.com/protected](http://www.peakscientific.com/protected).

Alternatively, you can send the completed form to Peak Scientific by post or email at [warranty@peakscientific.com](mailto:warranty@peakscientific.com).

Product Warranty Registration			
Contact name			
Email address			
Company			
Address			
City/town			
Postcode			
Country			
Telephone			
Generator serial #			
Model type			
Installation date			
Do you still use an alternative gas solution i.e. cylinders or bulk liquid?	Yes	No	
What gas requirements do you have in your lab?	Hydrogen	Nitrogen	Zero Air

**Extend your cover with**

Peak Scientific offer comprehensive gas generator after sales support packages. Peak [Protected] aftercare support can guarantee an on-site response within 72 hours\*, genuine parts from our ISO9001 approved factory and a 95% first-time fix rate. See our enclosed Peak [Protected] leaflet for further information.

**Important!**

You have 1 month to register your Peak Scientific product from the date of installation. Once registered the warranty will be honoured for a period of 12 months. If you wish to defer the installation of your generator, you must notify Peak Scientific immediately by emailing [warranty@peakscientific.com](mailto:warranty@peakscientific.com). For generators that remain unregistered after 1 month from the shipment date, the warranty will be considered active from the date of factory dispatch.

\* Complete Plan only

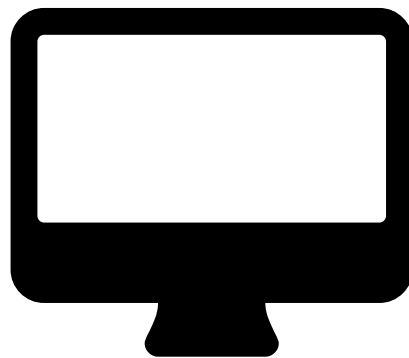

## Important!

You have **1 month to register** your Peak Scientific product from the date of installation. Once registered the warranty will be honoured for a period of 12 months. If you wish to defer the installation of your generator, you must notify Peak Scientific immediately by emailing [warranty@peakscientific.com](mailto:warranty@peakscientific.com). For generators that remain unregistered after 1 month from the shipment date, the warranty will be considered active from the date of factory dispatch.

# [**PEAK Protected**]<sup>TM</sup>

Peak Scientific has highly trained, fully certified Field Service Engineers located in over 20 countries across every continent around the world. This allows us to provide an industry-leading rapid response service to our customers. With **[Peak Protected]**, your laboratory's productivity becomes our top priority.

To discuss Peak Protected generator cover and payment options speak to your local Peak Representative or for further information contact: [protected@peakscientific.com](mailto:protected@peakscientific.com)

## **Peak Scientific**

Fountain Crescent  
Inchinnan Business Park  
Inchinnan  
PA4 9RE  
Scotland, UK

**Tel:** +44 141 812 8100

**Fax:** +44 141 812 8200

For further information on any of our generator products please contact [marketing@peakscientific.com](mailto:marketing@peakscientific.com)

