

Lunch talk at  
18<sup>th</sup> IMSC  
Bremen

# Orbitrap Mass Spectrometry: from Dream to Mainstream

Dr. Alexander Makarov  
Thermo Fisher Scientific

September 2, 2009

Orbitrap is...



...in Bremen!

# Long time ago...



A. Pekaln

*“If you really want to do something useful, develop an ideal analyzer for my spark ion source!”*

*International Journal of Mass Spectrometry and Ion Processes*, 76 (1987) 125–2

Elsevier Science Publishers B.V., Amsterdam – Printed in The Netherlands

Review

**THE IDEAL MASS ANALYZER: FACT OR FICTION?**

**CURT BRUNNÉE**

*Finnegan MAT, D 2800 Bremen (F.R.G.)*

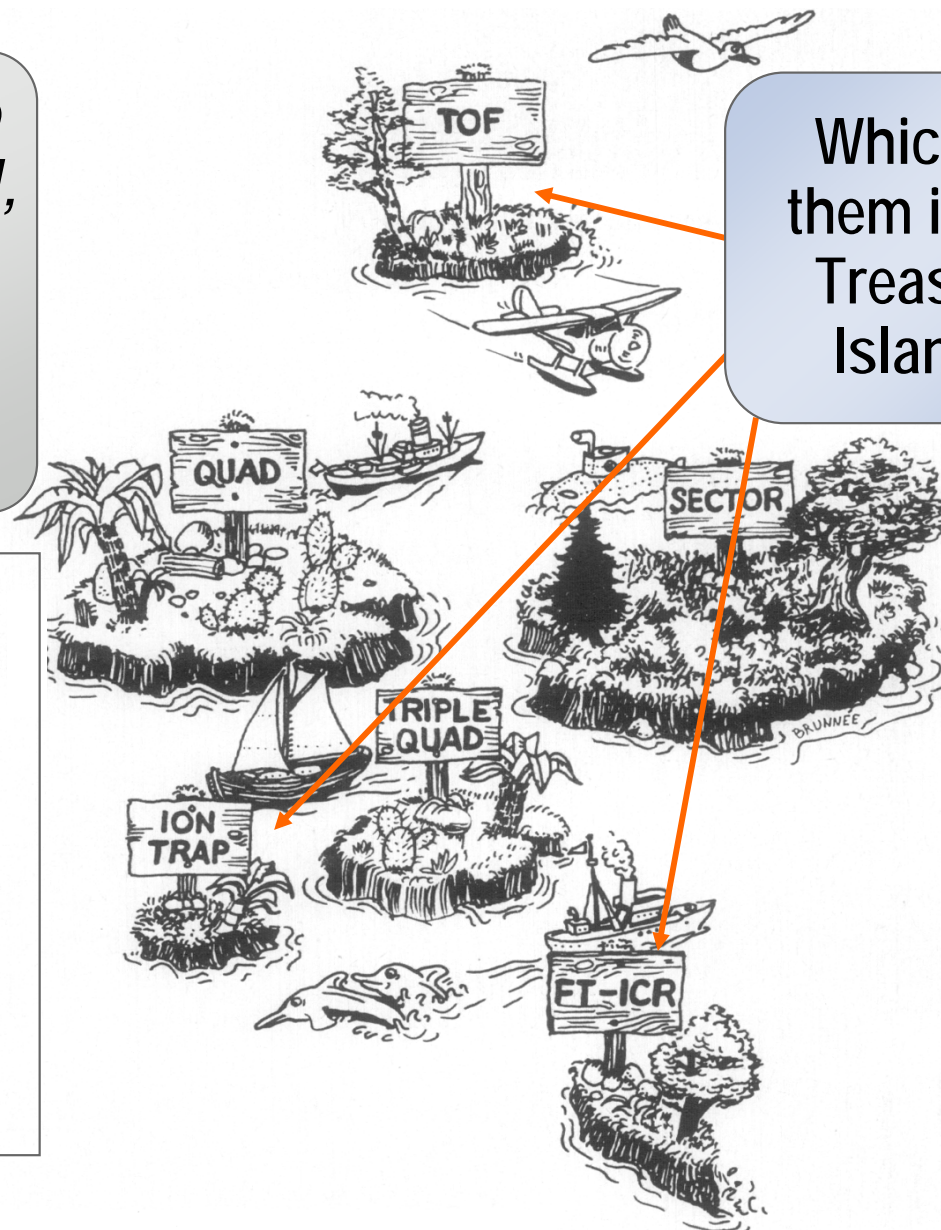

# Long time ago...

Why can't we trap ions by electrostatic field alone?

?\*?!%, don't you know that ions can not **rest** in electrostatic fields?

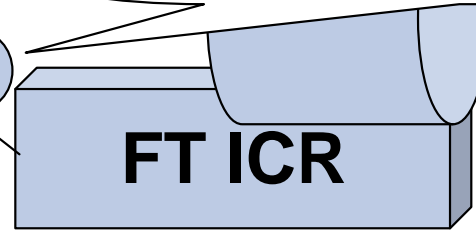
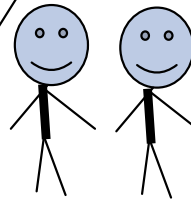

## Ideal Mass Analyzer?

### Earnshaw's theorem (1842):

*"A collection of point charges cannot be maintained in a stable **stationary** equilibrium configuration solely by electrostatic interaction of the charges"*

...but **moving** ions could be stable!

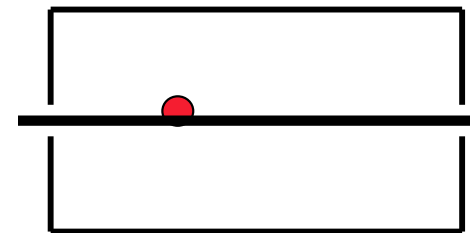

**Orbital traps**  
Kingdon (1923)

No promise?

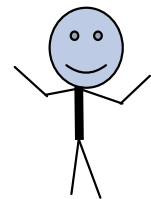

# TOF Adventures: Prelude to the Orbitrap

$$U(r, z) = \frac{k}{2} \cdot \left\{ z^2 - r^2 / 2 + R_m^2 \cdot \ln(r / R_m) \right\}$$

Gall L.N., Golikov Y.K., Aleksandrov M.L., Pechalina Y.E.,  
Holin N.A. *SU Pat. 1247973*, 1986.

1st implementation of quadro-logarithmic field  
in mass spectrometry

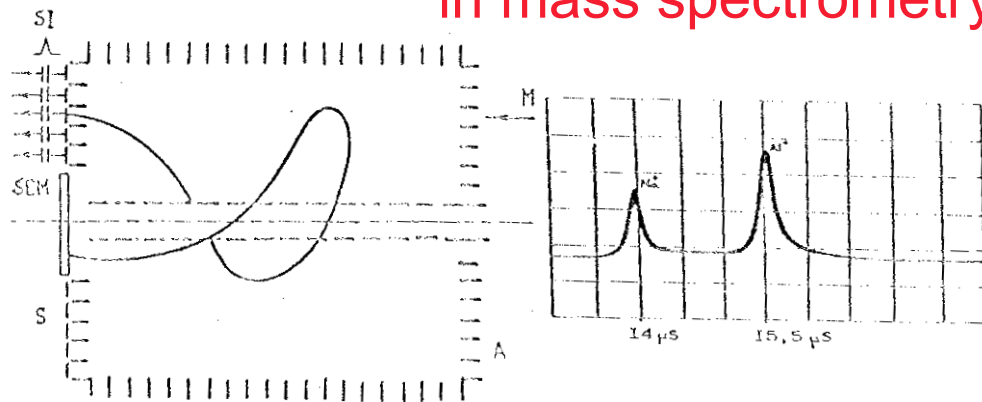

“A mosquito-catcher”

Dust impact TOF

*MEPhI, 1991*

REMPI-TOF

*GPI RAN, 1991*

MALDI Mag-parTOF

*Kratos, 1992/Warwick Uni. 1995*

MALDI TOF-parTOF

*Warwick Uni., 1996*

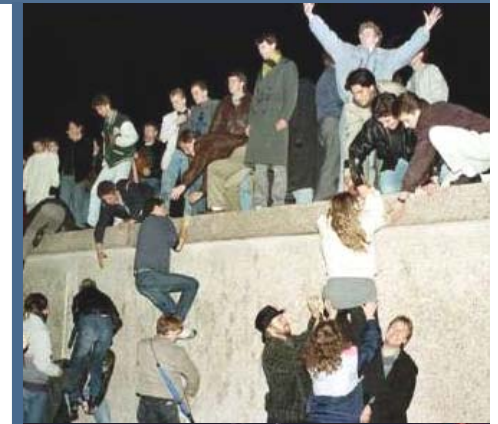



# Life in a Start-up: HD Technologies (Manchester, UK)

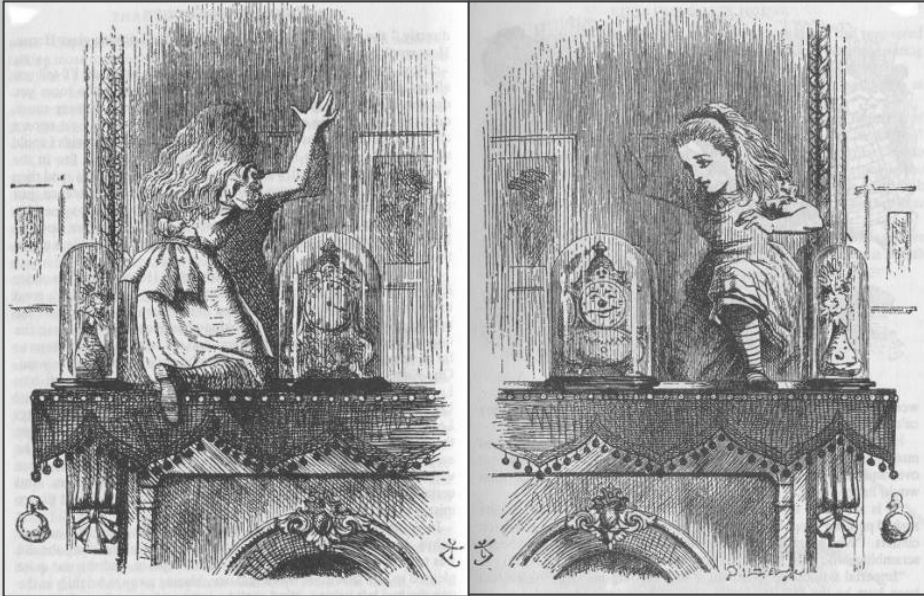

*“Now, here, you see, it takes all the running you can do, to keep in the same place. If you want to get somewhere else, you must run at least twice as fast as that!”*

**– Red Queen in L. Carroll  
“Through the looking glass” (1871)**



*“To succeed, we need to build something really new in a garage. It would be nice to have resolution of FT ICR and sensitivity of TOF with size and capabilities of a quadrupole ion trap!”*

**– Steve Davis**

# Which way to go?

- Why not just to carry on and stay with TOFs?
- Because of inherent TOF compromises:
  - Resolving power vs sensitivity
  - Dynamic range, resolving power, mass accuracy vs. complexity and life-time of detection system
  - Resolving power vs mechanical complexity/ size
  - Dynamic range, mass accuracy vs speed



V.Vasnetsov (1882)  
“At the crossroads”

**Many of these compromises are still in place...**



*“I am looking for a technology that will provide mass accuracy for all peaks, even close to the detection limit”*

*– Ian Jardine, visiting in 1998*

For FTMS, detection system was known not to be the bottleneck. So “only” an appropriately compact analyzer was lacking... This should be easier for a physicist!

# Orbital Trapping (*déjà vu*)

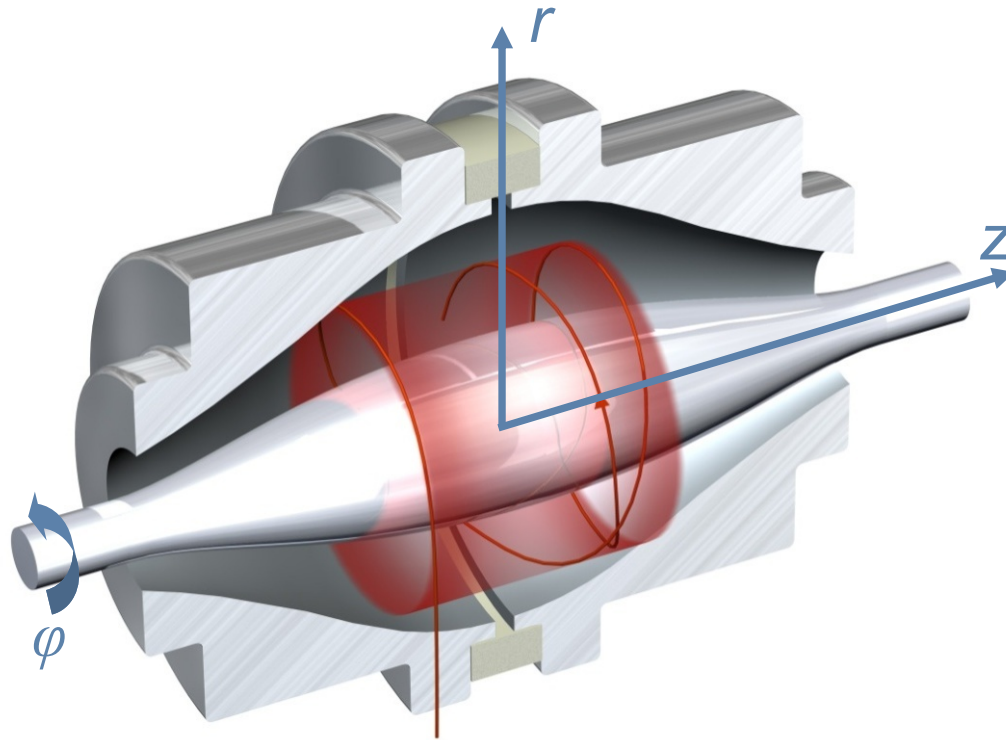

Characteristic frequencies:

- Frequency of rotation  $\omega_\phi$
- Frequency of radial oscillations  $\omega_r$
- Frequency of axial oscillations  $\omega_z$

$$\omega_\phi = \frac{\omega_z}{\sqrt{2}} \sqrt{\left(\frac{R_m}{R}\right)^2 - 1}$$

$$\omega_r = \omega_z \sqrt{\left(\frac{R_m}{R}\right)^2 - 2}$$

Quadro-logarithmic potential distribution:  
“ideal Kingdon trap”

$$U(r, z) = \frac{k}{2} \cdot \left\{ z^2 - r^2 / 2 + R_m^2 \cdot \ln(r / R_m) \right\}$$

“Beauty will save the world.” - F.M. Dostoevsky

$$\omega_z = \sqrt{\frac{k}{m/q}}$$

*Only this frequency does not depend on energy, angle, etc. and is used for mass analysis*

# Detection of Ions in the Orbitrap

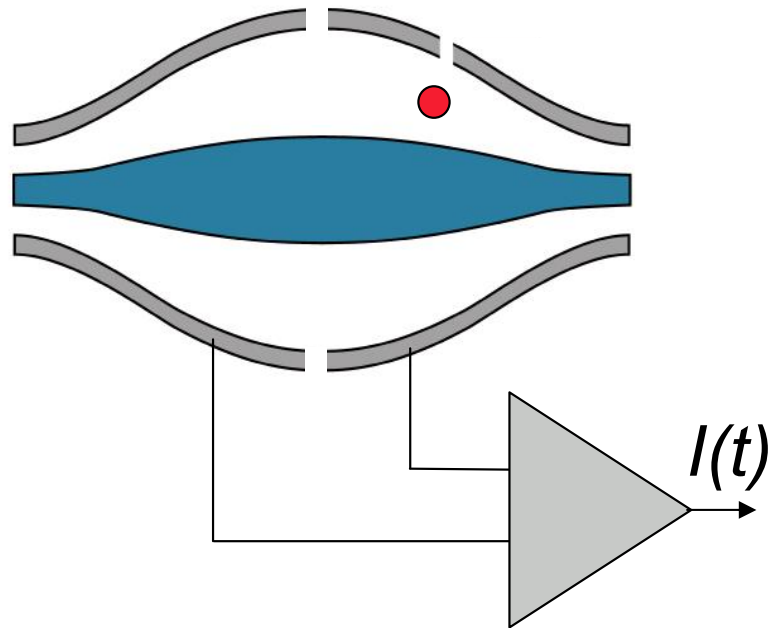

## *Image current detection*

- All-mass detection (Felgett advantage)
- Noise equivalent to  $<10 \bar{e}/\sqrt{\text{Hz}}$



- Frequency of axial oscillations of each ring induces an image current on split outer electrodes
- Multiple ions in the Orbitrap generate a complex signal with frequencies determined using a Fourier Transformation
- Detection could be done with high linear dynamic range while limitations on processing speed are sorted out by computer revolution



# Detection of Ions in the Orbitrap

## Detection on electron multiplier

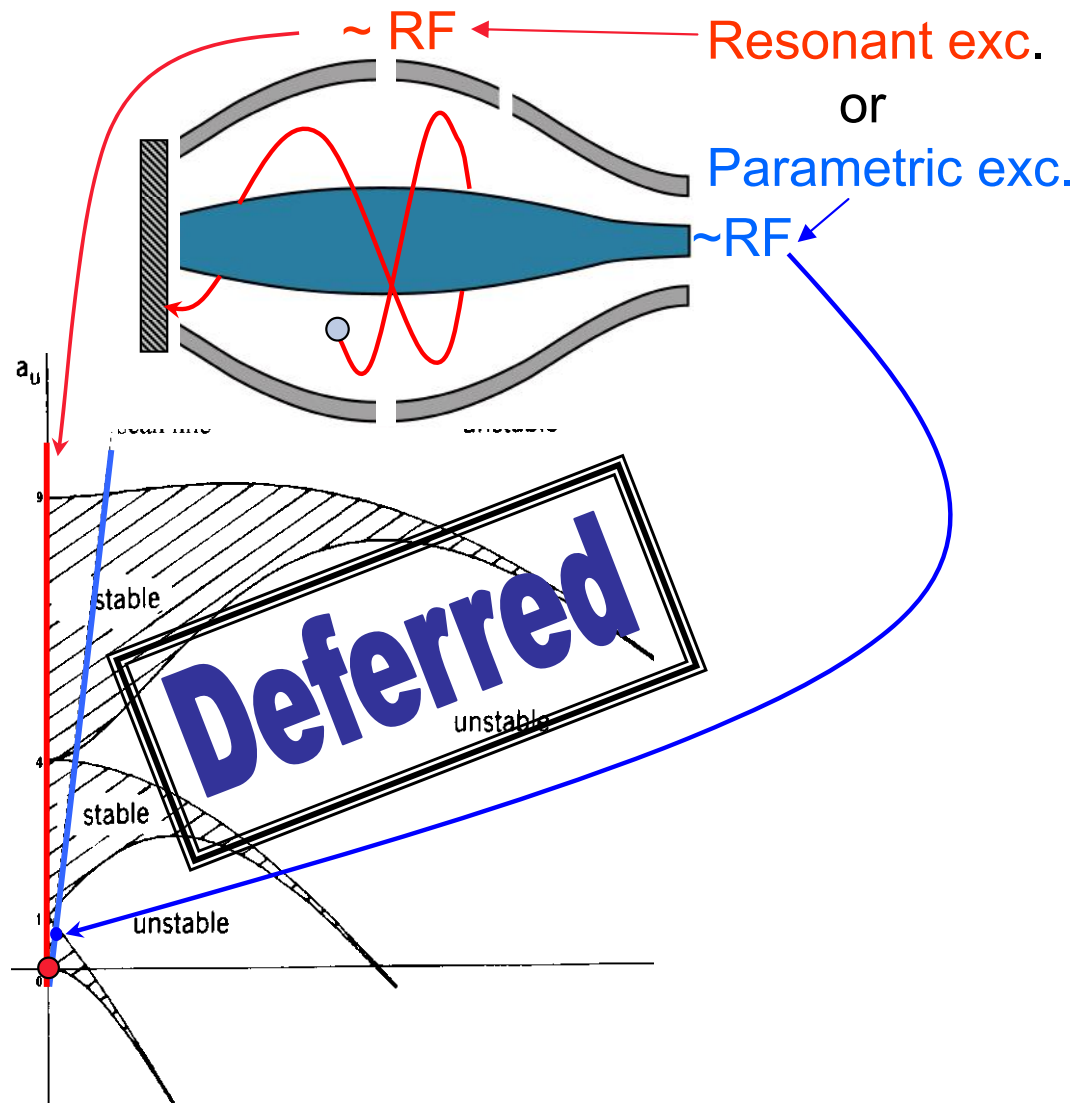

- Scans as in RF traps
- $R \uparrow$  when scan speed  $\downarrow$
- Single-ion detection
- No collisions!

# Getting into the Orbitrap

- The “Ideal Kingdon” field known since 1950’s, but not used in MS. **Why?**
- Because there is a catch (as always in traps):  
**How to get ions into it ?**
- Ions coming from outside into static electric field zoom past, like a comet from an outer space through the solar system
- The way out:  
**Field is not static when ions come in!**
- By lowering central electrode voltage, a barrier is created to prevent ions from reaching the electrode-  
**while ions are still entering!**
- Thus we arrive at the principle of:  
**Electrodynamic Squeezing**

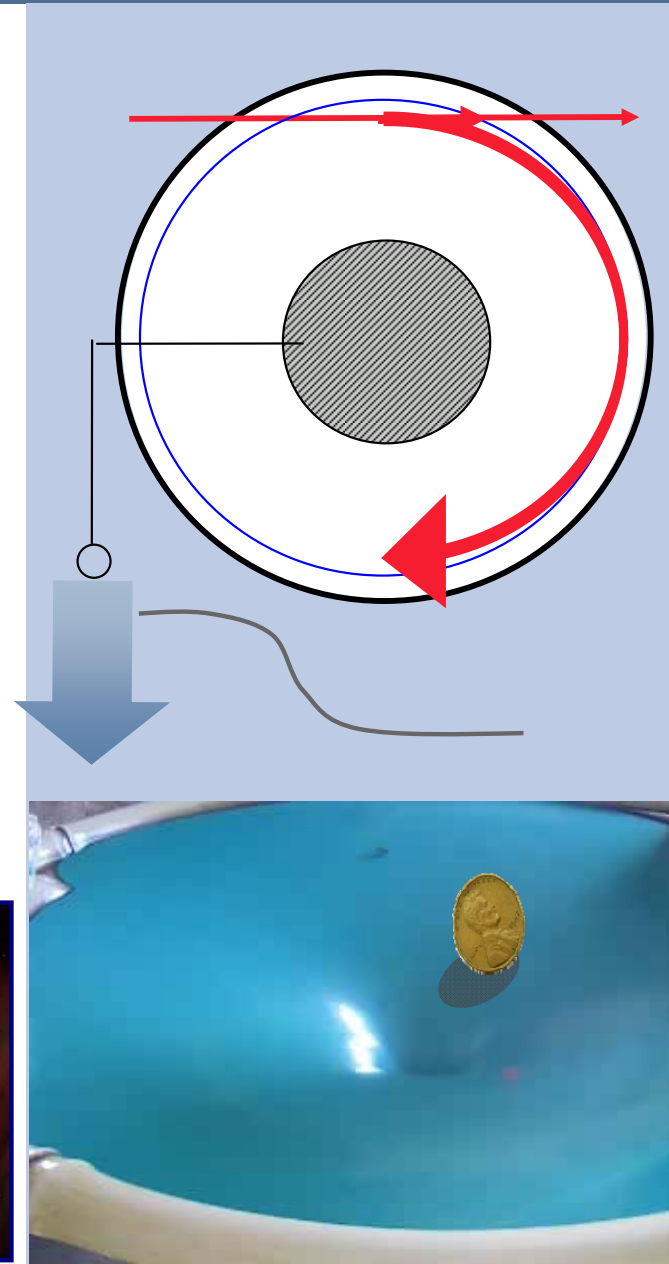

# “Slow injection”- the path to the instrument?

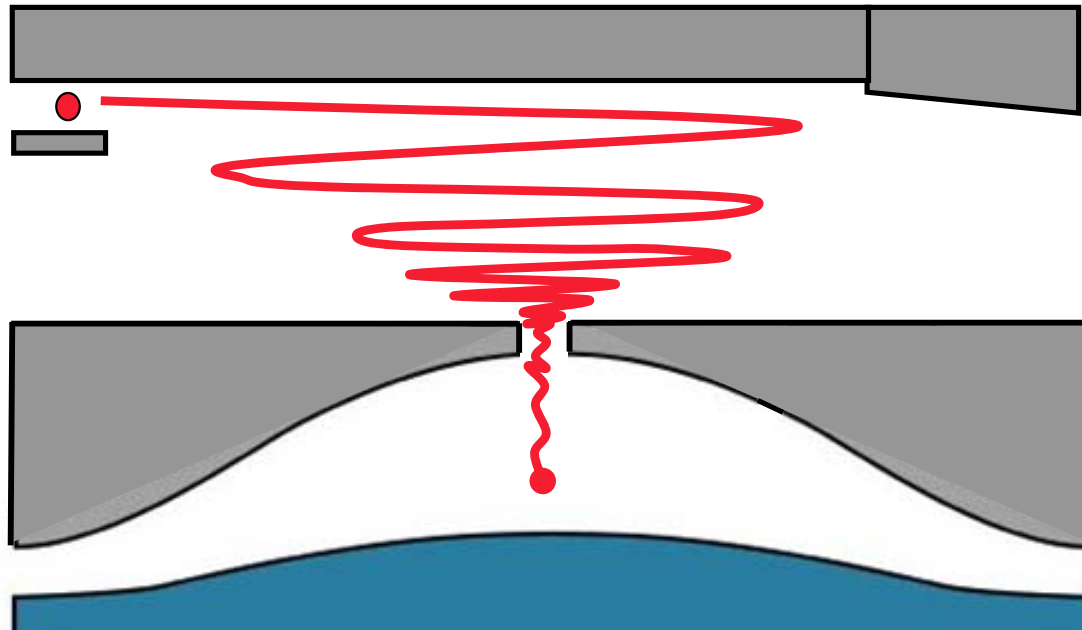

“Slow injection”:  
suits conventional  
RF storage!

£45 K (\$70 K)!

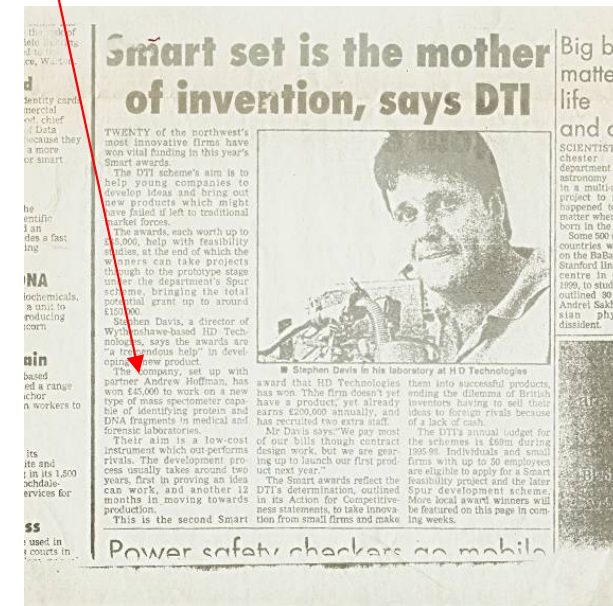

Let's cut metal!

# Work begins...with a change of plan!

... but we need also to pay bills...

SMB-EI/HSI-oaTOF

ICP-oaTOF

EI-oaTOF

MAB-oaTOF

ESI-oaTOF

MALDI-TOF-TOF

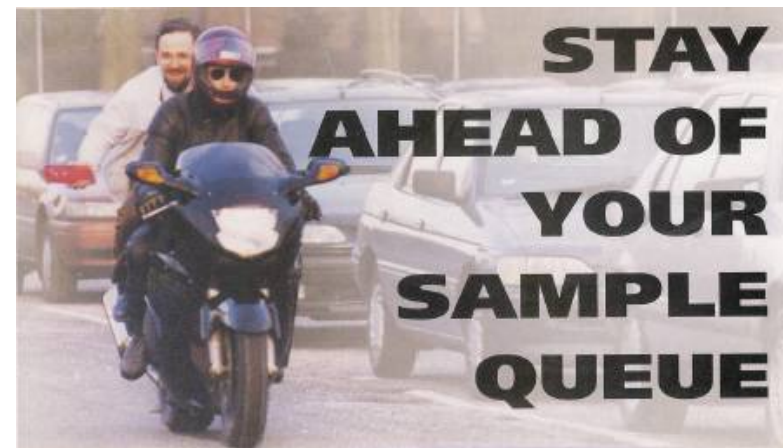

Is anything missing?  
Electronics...

*Proof of principle is  
the main priority!*

*So let's abandon "slow  
injection" and find a way out...*

Way out: fast injection from  
a pulsed ion source



Bob Lawther



Andy Hoffmann

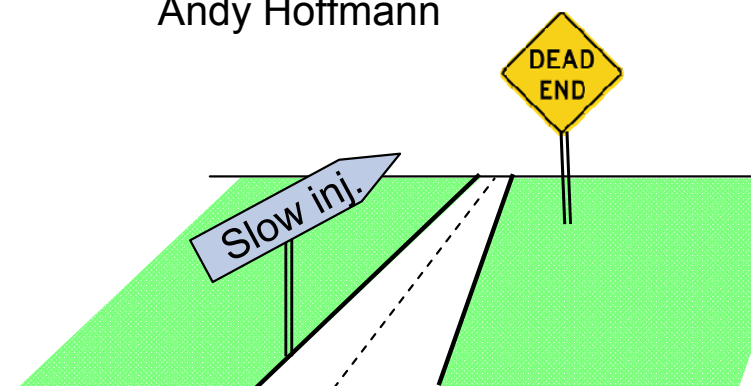



# “Fast” Injection and Formation of Ion Rings

- A short ion packet of one  $m/z$  enters the field
- Increasing voltage squeezes ions
- “Excitation by injection” is initiated
- Voltage stabilises and ion trajectories are also stabilized
- Angular spreading forms a ROTATING RING

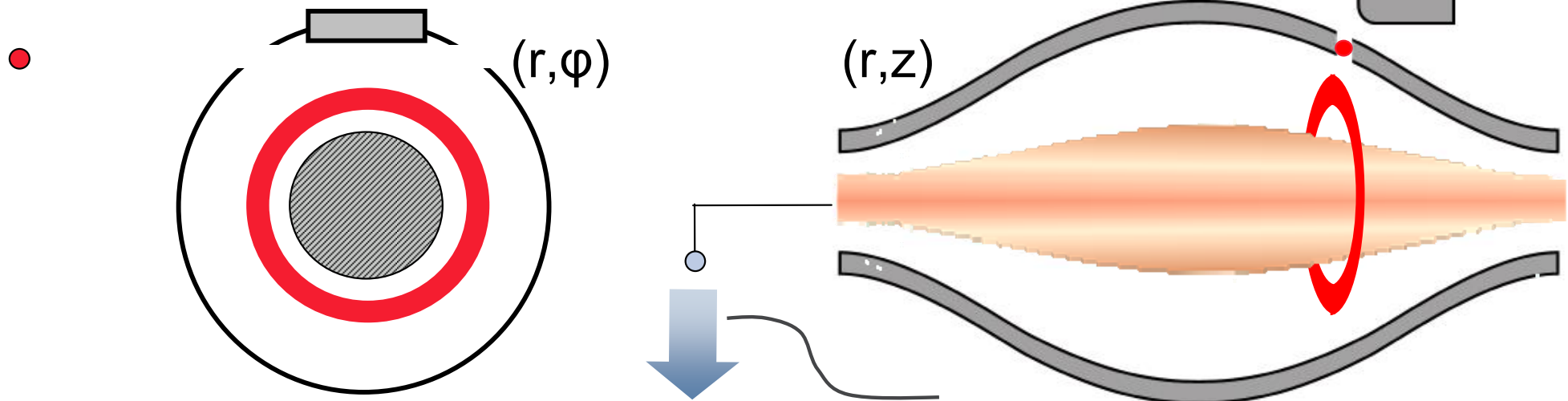

***Laser source for a start- for other sources let's work it out later...***

# Proof of Principle: Orbitrap with Laser Ion Source

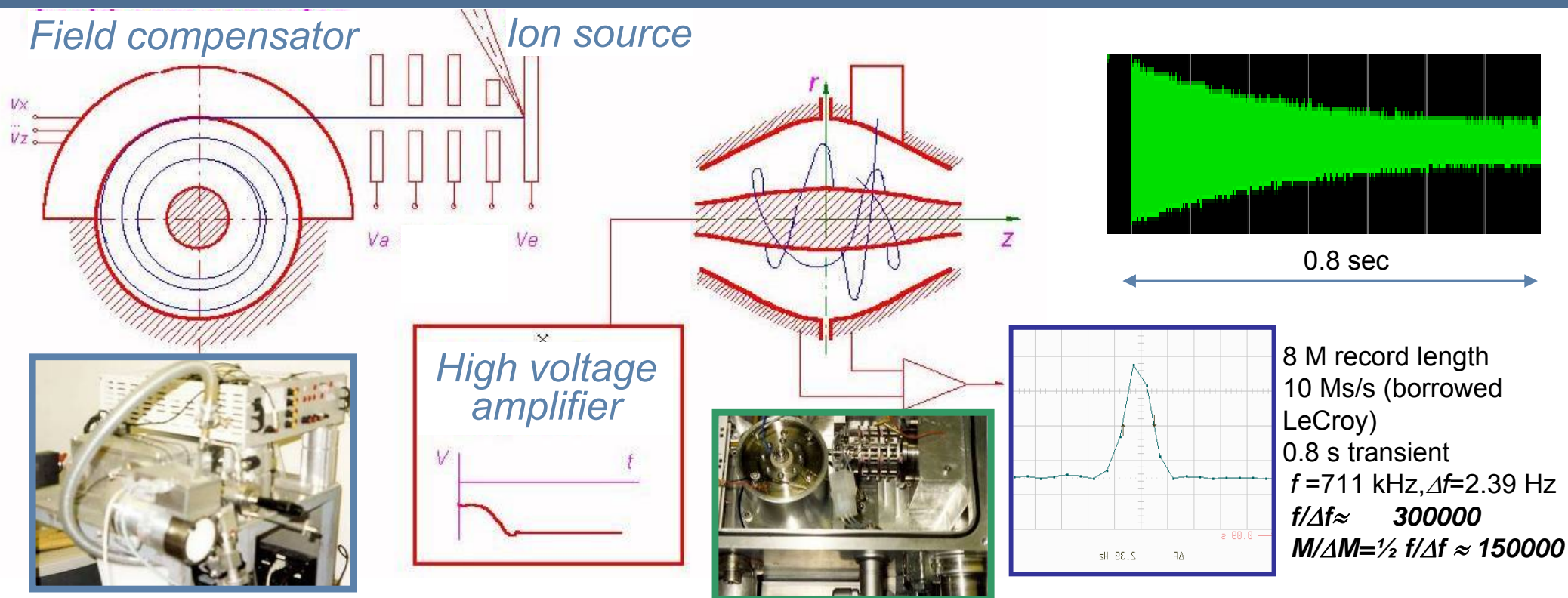

## Unexplained Fortunate Occasion (UFO) #1:

Our supplier got a new turning machine on which 1 set of electrodes was machined and worked nicely. It has NEVER been possible to make another set of working electrodes again on this machine (or any other machine of that type)...

**UFO #2:** “Shorted” outer electrodes became “un-shortened” and worked on the day of crucial presentation to Thermo expert team S-4 (Stafford, Schwartz, Syka, Senko)

# Reasons Why Orbitrap Would Never Work

- Not possible to provide ion packets with required spatial and temporal parameters for continuous ion sources
- Tolerance requirements on electrodes are not realistic
- Injection and central slots will ruin resolving power and mass accuracy
- Vacuum requirements are ridiculous and can not be met
- Ions can not be injected with high efficiency
- Wide mass range can not be injected and captured
- Image current preamplifier will be destroyed by pick-up during injection
- Noise from high voltage power supply will overwhelm preamplifier
- Surface potentials would disturb and scatter ions
- Mass accuracy will be poor because of voltage drift & noise
- Large ion numbers cannot be properly injected or analyzed
- Electrodes shape, rotational and radial frequencies will cause unmanageable mass-dependent harmonics

***All these reasons are valid – first one demanding most of work!***

Under new management

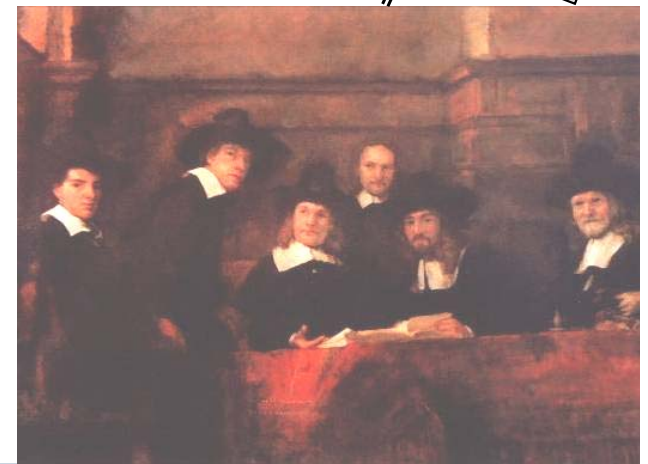

# Converting Continuous Ion Beams into Packets

Orbitrap  
"fast inj."

Orbitrap  
"slow Inj."

TOF

FT ICR

RF ion trap

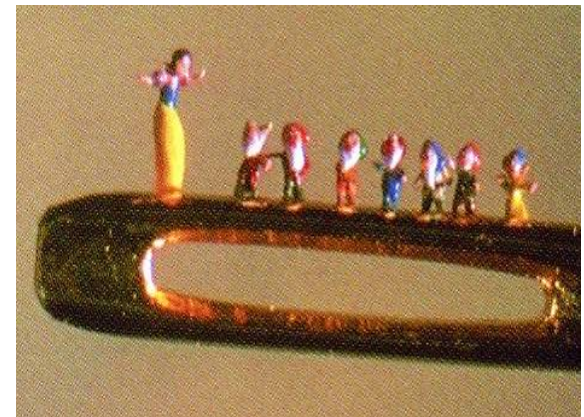
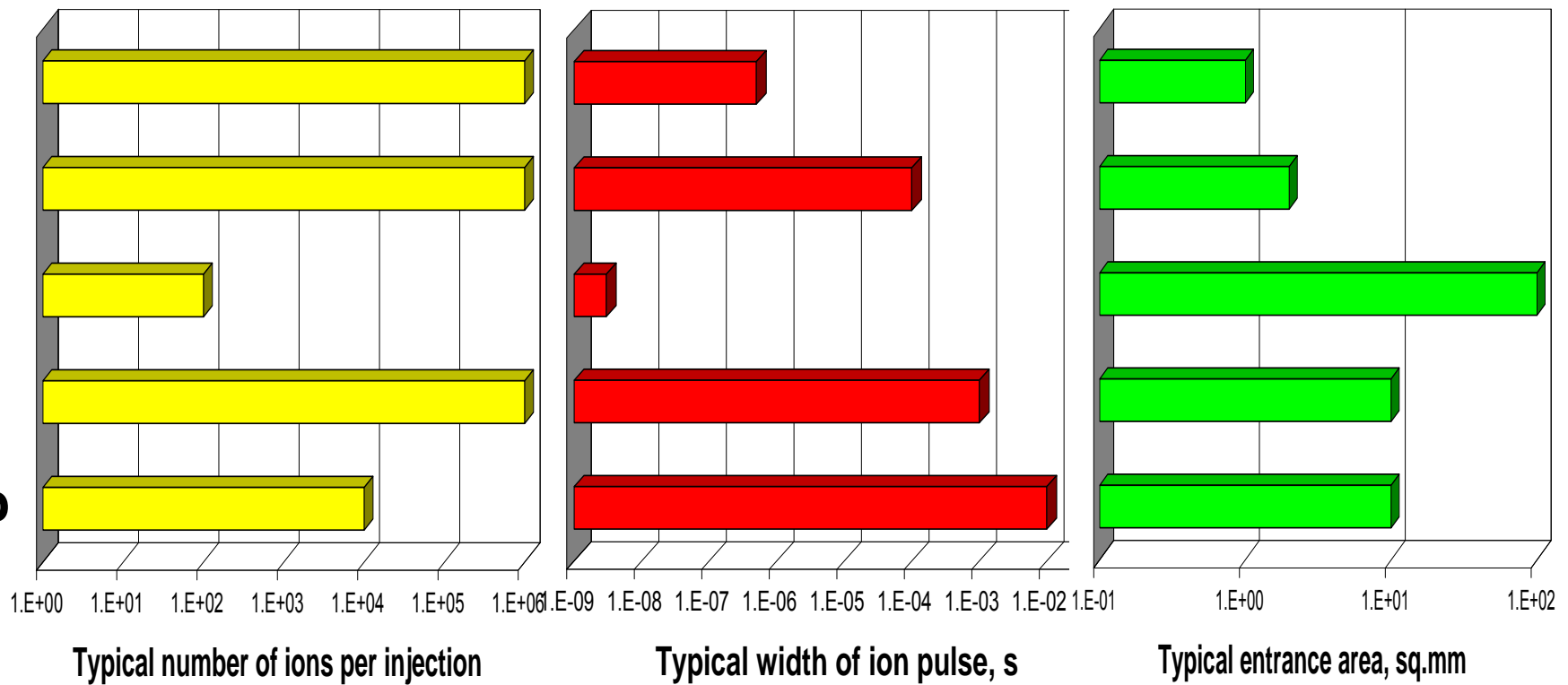



# ESI-Orbitrap: Axial "Fast Injection"

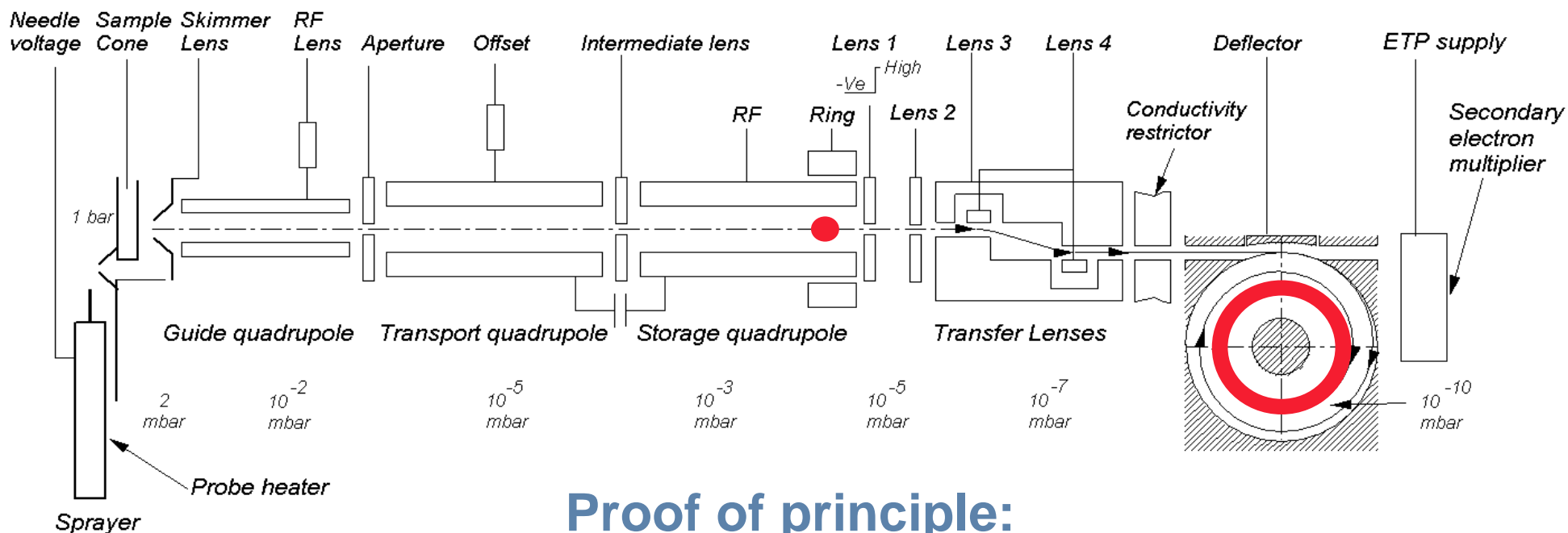

## Proof of principle: High resolution ESI spectra (2001)



Mark Hardman

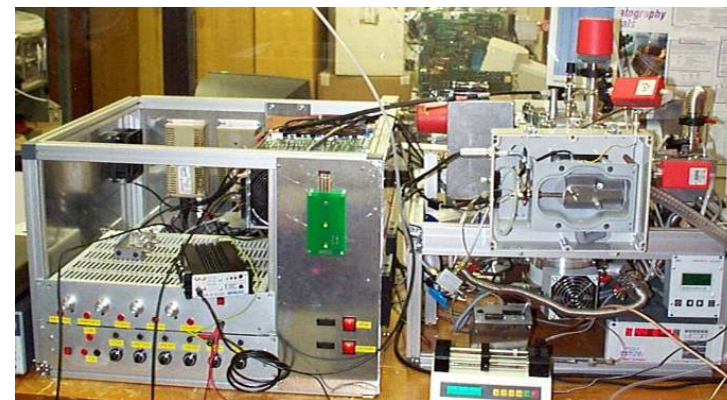
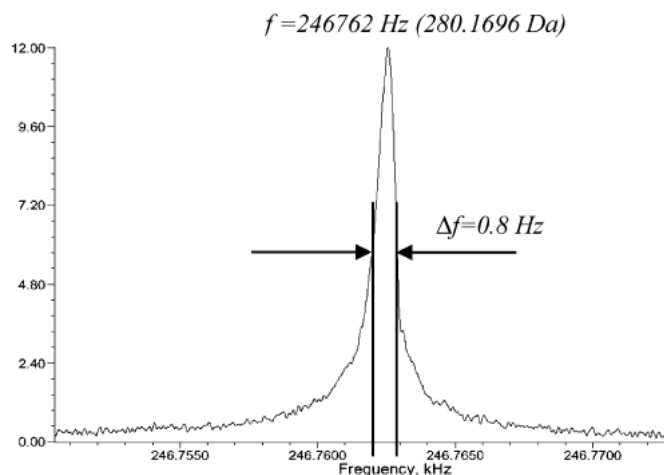

# Life is Never Simple: the Great Relocation



E. Denisov



A. Kholomeev



M. Senko

## The last push of HD Tech/Masslab team:

- 1 research prototype for Prof. Cook's group (*Purdue*)
- 1 research prototype for Bremen factory



R. Noll



G. Jung



S. Horning



R. Pesch



J. Srega



Experiments with  
resonance  
excitation/  
de-excitation

# Another Change of Plan...

## Axial ejection- the outcome (2003):

At large ion numbers, peak width becomes comparable with half-period of oscillations → poor coherence, discriminations, etc.

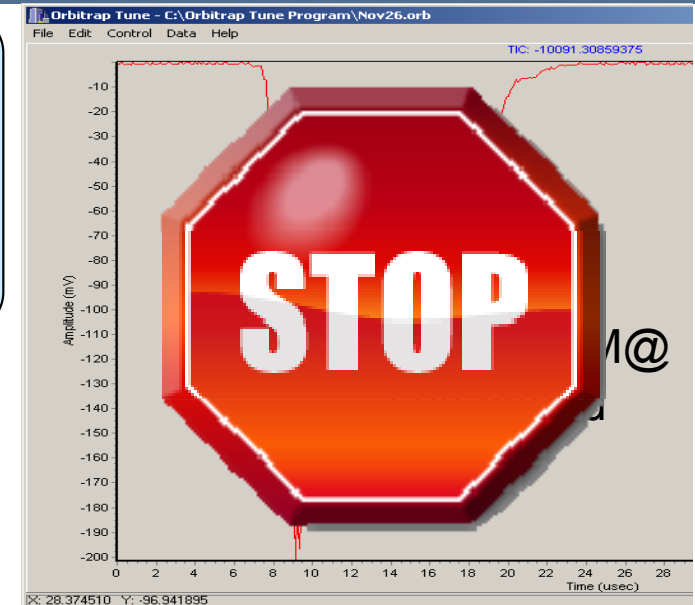
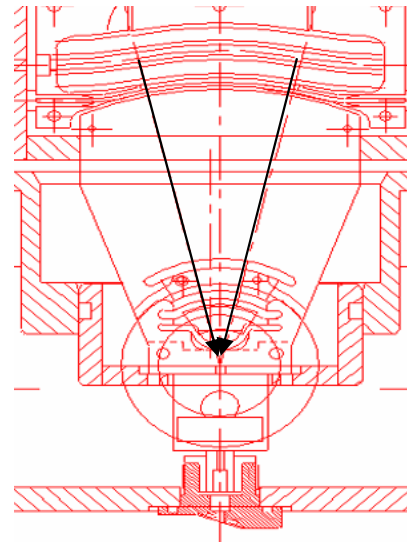

## UFO #3 (mid-2003):

As axial extraction approaches disappointment, radial “fast injection” starts to show promise!





# Curved Linear Trap (C-trap): Radial “Fast” Injection

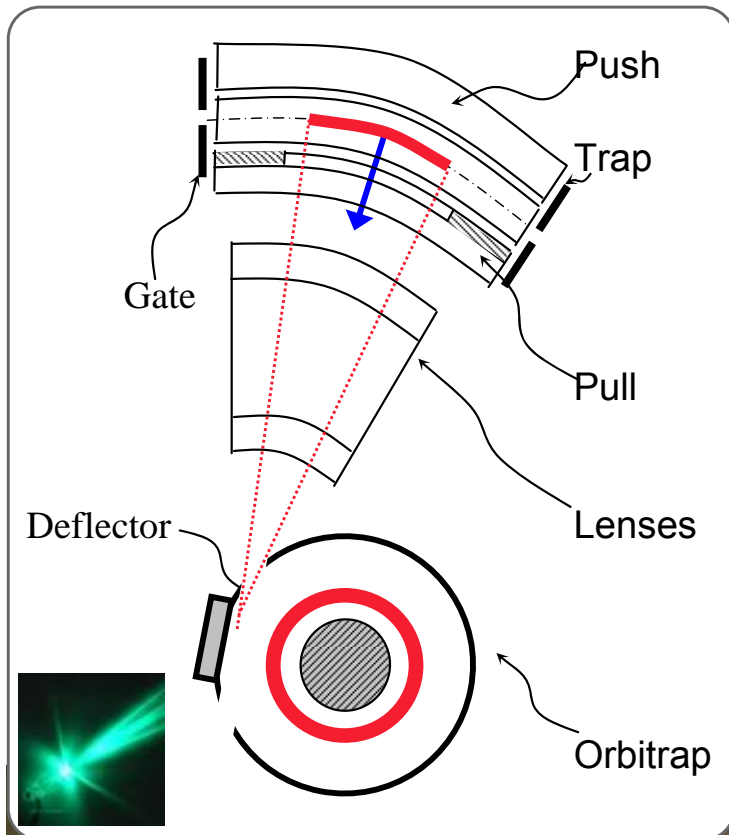

- Ions are stored and cooled in a curved RF-only quadrupole (C-trap)
- RF is ramped down, radial DC is applied
- Ions are ejected along lines converging on the orbitrap entrance).
- As ions enter orbitrap, they are picked up and squeezed by its electric field

...and it works!

A.Kholomeev + E.Denisov + A.Makarov +



W. Balschun



O. Lange

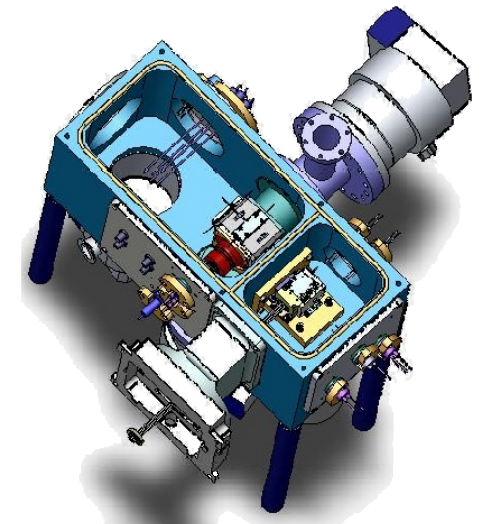

Summer 2003-Spring 2004



# To Build or Not to Build?

## LTQ and LTQ FT: giants which made Orbitrap possible

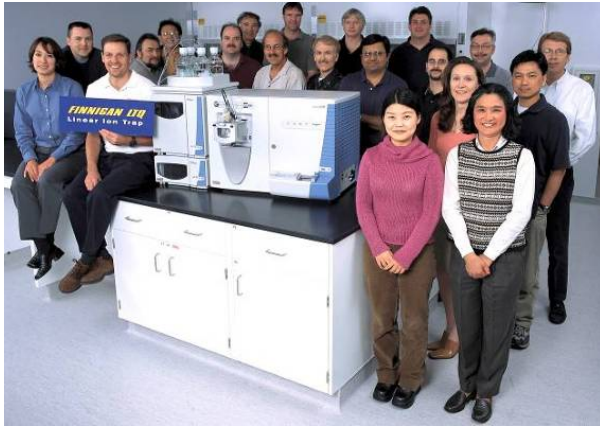

***“Let’s just use Orbitrap in the same way as ICR!”***

### **MURPHY'S LAW**

**What can go wrong, will go wrong.**

Essentially, the laws of nature always work, whether we are paying attention or not.

**(Equipment blows to protect fuses.)**

**(Interchangeable parts aren't & fail-safes don't.)**

**Mrs MURPHY'S COROLLARY**

**Murphy is too much of an optimist.**

### ***Why it should all end in disaster:***

- Ultra-precision electrodes cannot be produced in large quantities
- No guarantee that performance of a working breadboard can be reproduced in series
- Too many ion optical and electronic units which have never been produced in series
- Central electrode voltage cannot be held stable
- Vacuum and noise requirements cannot be routinely fulfilled in such a compact package

***If it works, It will be too good to be true!***

# Influence of (in) Correct Electrode Shape

UFO #4 (2002-2004): As electrodes prove to be really difficult to make, new manufacturing techniques come to the rescue.

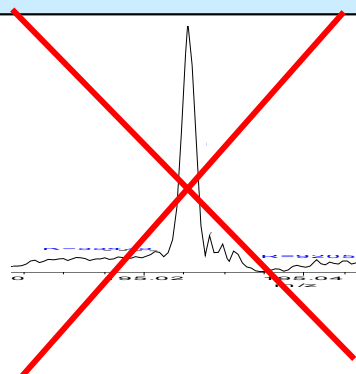
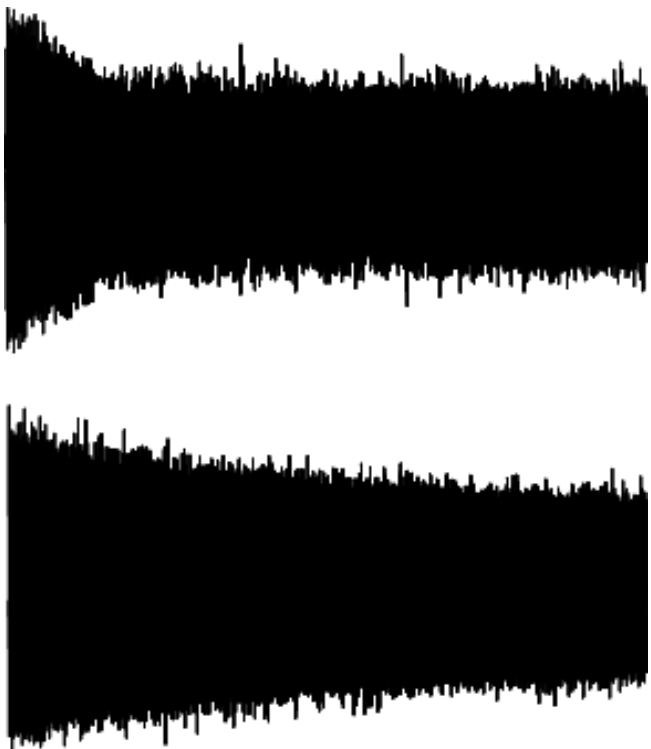

De-focusing + self-bunching = **bad peak shape**

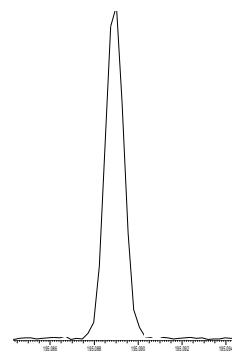

Correct tolerances = High resolution & **good peak shape**

**PASS**



M. Monastyrski



D. Grinfeld

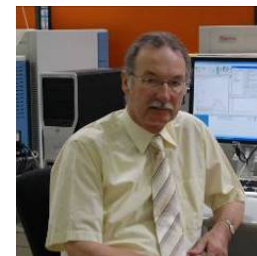
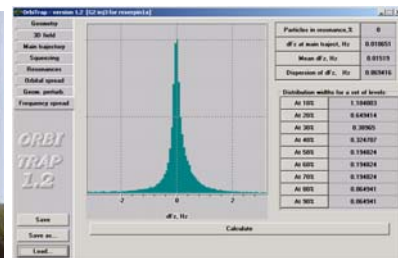

B. Laser



F. Schaefer

# LTQ-Orbitrap: All Technologies Come Together

## 1. Ions are stored in the linear trap of LTQ

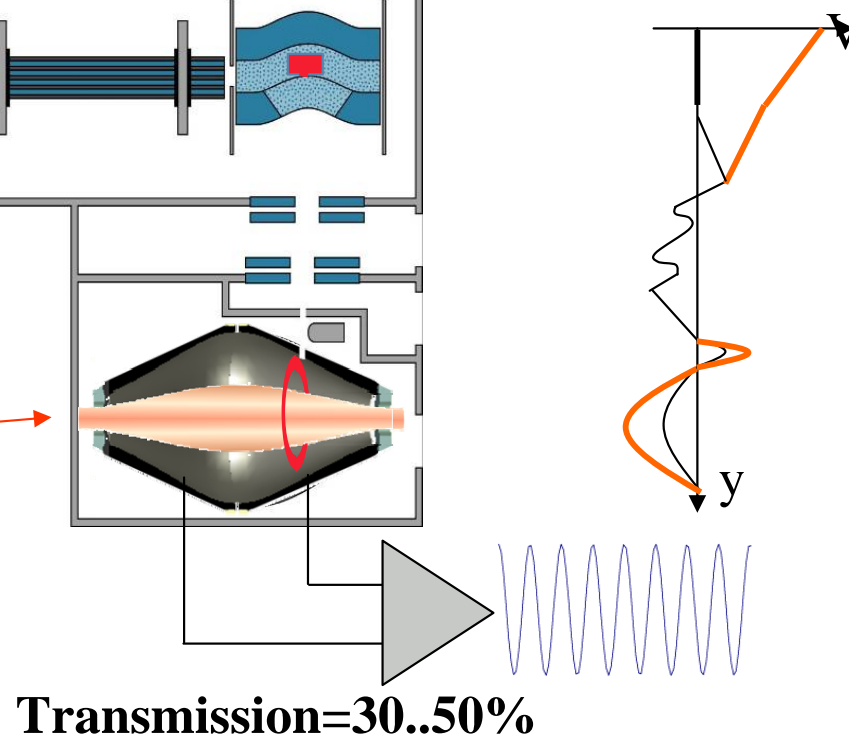
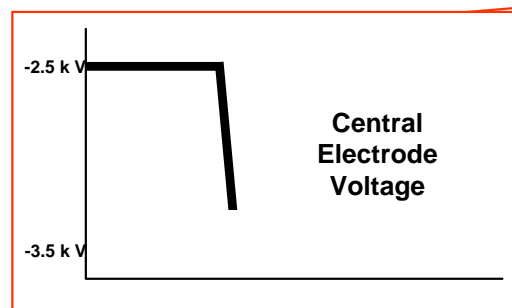
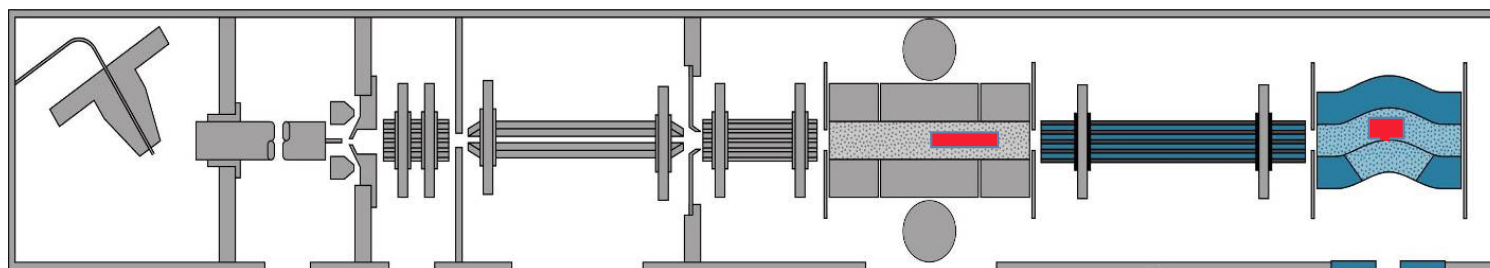
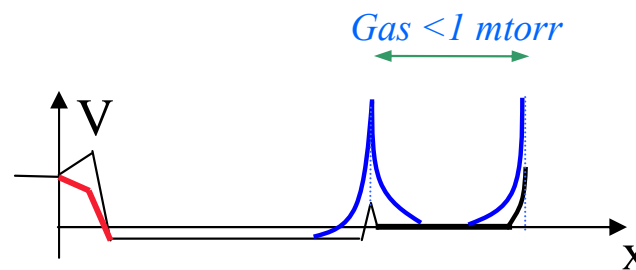



# Tree of Orbitrap mass spectrometry: status in 2009

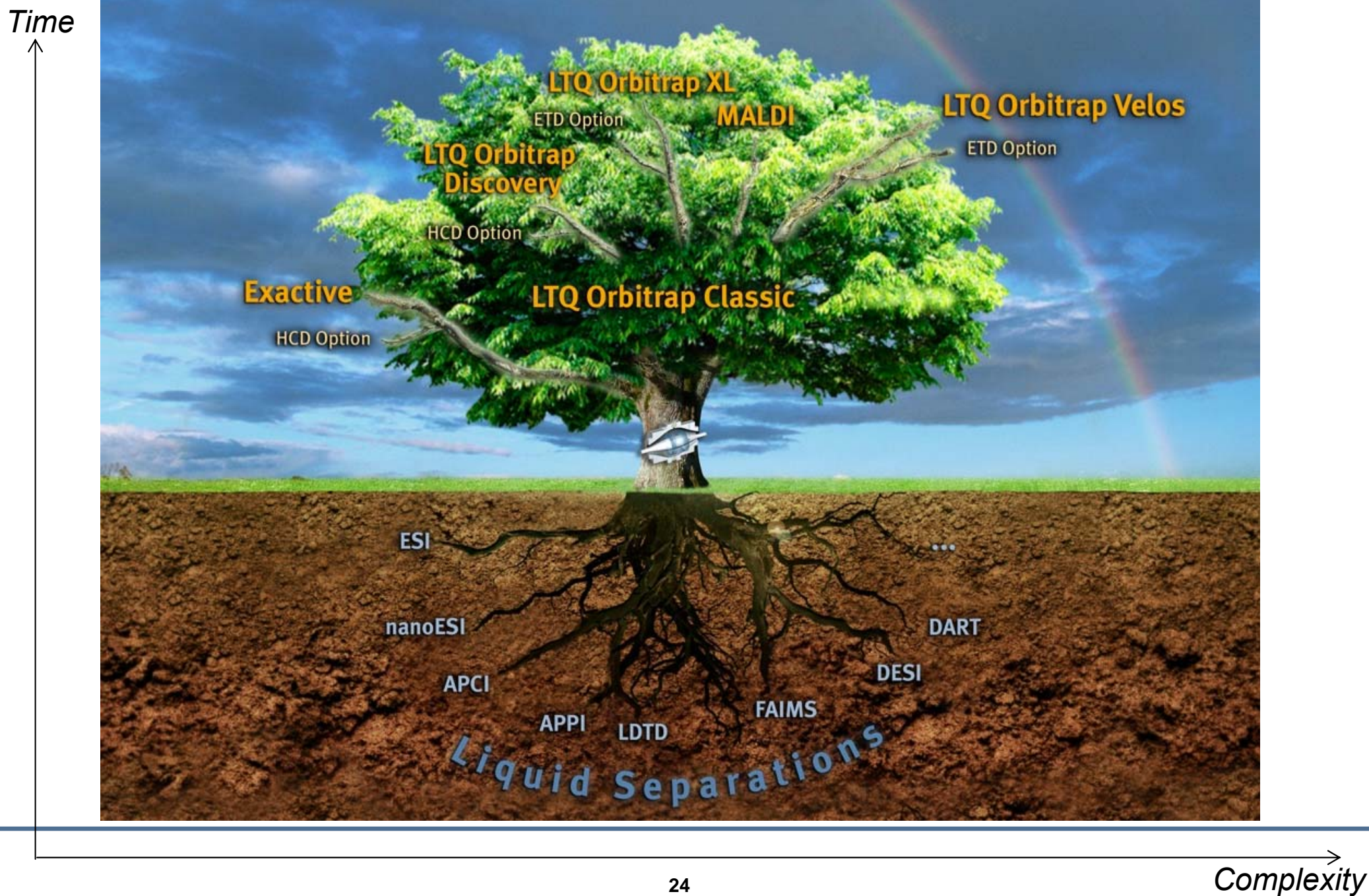



# General features of Orbitrap mass spectrometry

- Main intrinsic features:
  - image current detection
  - high resolving power
  - high space charge capacity
  - weak dependence of frequency on  $m/z$
  - high transmission from the C-trap to spectrum
  - robust and maintenance-free mass analyzer
- Mass accuracy is achieved from around LOD until the maximum signal: only few tens of ions from the source are needed to yield a peak with low-ppm mass accuracy!
- Though resolving power indeed goes down for higher spectra acquisition rates, dynamic range in every spectrum changes only slightly
- High sensitivity and dynamic range allow quantitation and faster acquisition of quality spectra
- High stability of the analyser ensures very stable external calibration

# ESI-Orbitrap *Exactive*<sup>TM</sup>

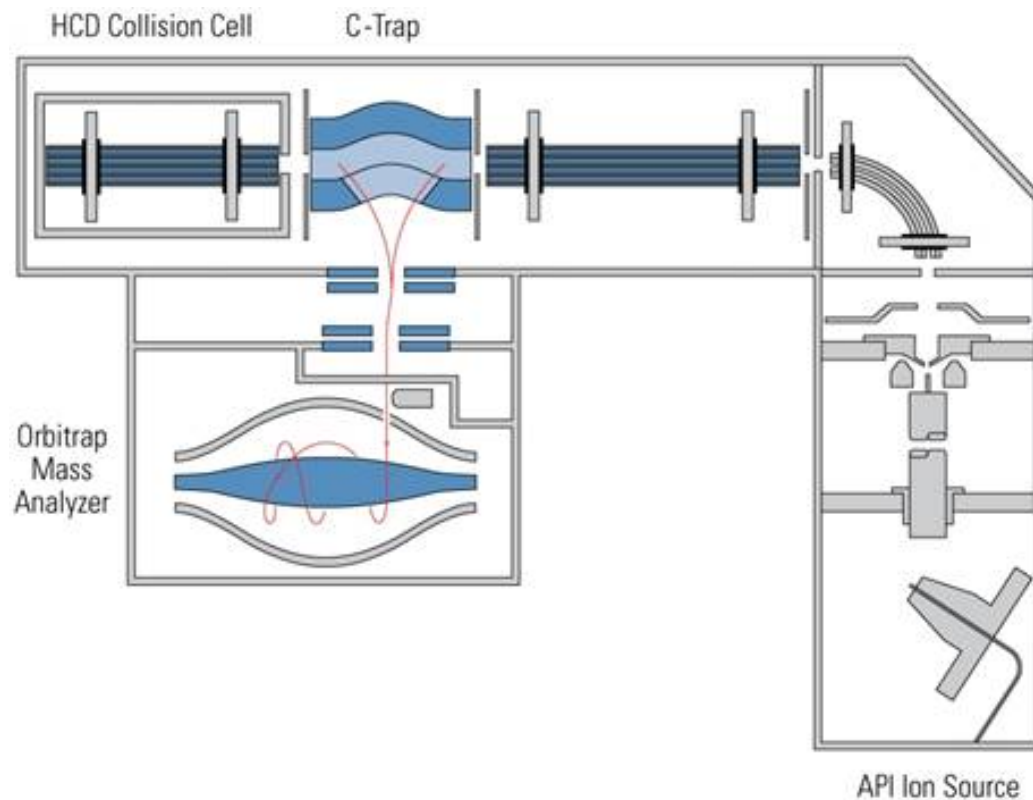

- First serial bench-top FTMS
- Highest speed FTMS (10 spectra/second) for fast LC
- No precursor mass selection
- High resolution, mass accuracy and sensitivity allow not only fast screening and qualitative analysis, but also *quantitative* analysis
- Ion population control using a pre-scan
- Fast polarity switching without the loss of external calibration
- Accurate mass is provided for all peaks in a *single* shot, from very low to very high S/N (>10,000)
- Additional dimension of analysis: all-ions fragmentation in an HCD cell

# New hybrid for proteomics: LTQ Orbitrap Velos

- Main emphasis:
  - higher speed of MS/MS not on paper (e.g. for calibration mixtures) but for real-life samples
  - higher quality and choice of MS/MS methods

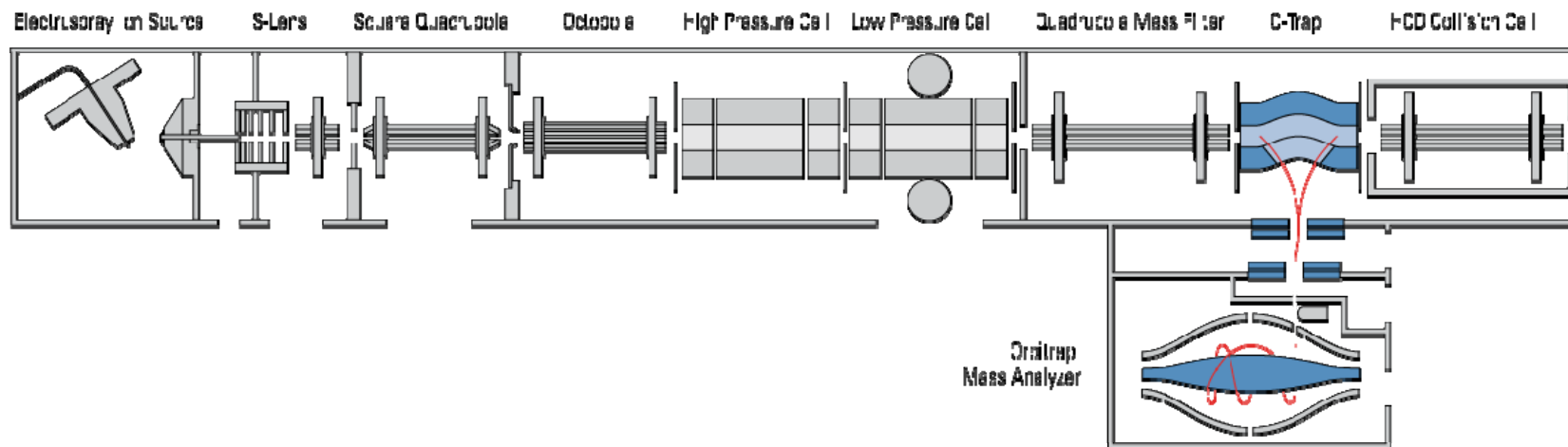

Tuesday **3:00 – 3:20**

Eduard Denisov, E. Damoc, J. Griep-Raming, O. Lange, A. Makarov, H. Kuipers, P. Remes, J. Schwartz, D. Taylor, T. Moehring and V. Zabrouskov:

*"A New Instrument for High-speed Proteomics: Orbitrap Mass Analyzer Interfaced to a Dual Linear Trap"*

# Conclusion

- Orbitrap mass analyzer offers a unique and very valuable combination of analytical parameters
- New analytical methods are made possible by new Orbitrap technology
- High-resolution wide mass range quantitation is going to become a new paradigm for peptide quantitation
- Increase of signal intensity by better transmission + higher scan rate = increase of number of identifications in real-life samples and their reliability.
- We are entering the era of high-speed proteomics, with 5-10 MS/MS per second for real-life samples!

*Further reading:*





# Acknowledgements

## My Family:

Anna Makarova  
Dasha Makarova  
Nikita Makarov

## My parents:

Alla & Alexei Makarov



## Development teams:

- LTQ
- LTQ FT
- MALDI
- ETD
- Exactive
- LTQ Velos

## Colleagues:

### Manchester, UK:

*S. Davis*  
*A. Hoffmann*  
*R. Lawther*  
*M. Hardman*  
*N. Demetriades*  
*J. Hughes*  
*B. McKnight*  
*K. Worthington*  
*S. Smirnov*

### San Jose, CA:

*E. Hemenway*  
*M. Antonczak*  
*M. Senko*  
*J. Syka*  
*J. Schwartz*  
*V. Zabrouskov*  
*T. Second*  
*I. Jardine*  
*T. Ziberna*  
*T. Second*  
*V. Zabrouskov*

### Bremen, DE:

*E. Denisov*  
*A. Kholomeev*  
*W. Balschun*  
*O. Lange*  
*K. Strupat*  
*S. Horning*  
*R. Pesch*  
*J. Srega*  
*G. Jung*  
*W. Huels*  
*F. Czemper*

*O. Hengelbrock*  
*A. Wieghaus*  
*J. Griep-Raming*  
*E. Schroeder*  
*U. Froehlich*  
*D. Nolting*  
*R. Malek*  
*T. Moehring*  
*H. Muenster*  
*M. Kellmann*  
*M. Zeller*  
*S. Strube*

**Thank you !**