

NOTICE: This document contains references to Varian. Please note that Varian, Inc. is now part of Agilent Technologies. For more information, go to [www.agilent.com/chem](http://www.agilent.com/chem).



# *MiniVac Controller*

**Model 929-0196**

**Model 929-0197**

*(I) MANUALE DI ISTRUZIONI*

*(D) BEDIENUNGSHANDBUCH*

*(F) NOTICE DE MODE D'EMPLOI*

*(GB) INSTRUCTION MANUAL*

# MiniVac Controller





**VARIAN**  
*vacuum technologies*

*Dear Customer,*

*Thank you for purchasing a VARIAN vacuum product. At VARIAN Vacuum Technologies we make every effort to ensure that you will be satisfied with the product and/or service you have purchased.*

*As part of our Continuous Improvement effort, we ask that you report to us any problem you may have had with the purchase or operation of our product. On the back side you find a Corrective Action Request form that you may fill out in the first part and return to us.*

*This form is intended to supplement normal lines of communications and to resolve problems that existing systems are not addressing in an adequate or timely manner.*

*Upon receipt of your Corrective Action Request we will determine the Root Cause of the problem and take the necessary actions to eliminate it. You will be contacted by one of our employees who will review the problem with you and update you, with the second part of the same form, on our actions.*

*Your business is very important to us. Please, take the time and let us know how we can improve.*

*Sincerely,*

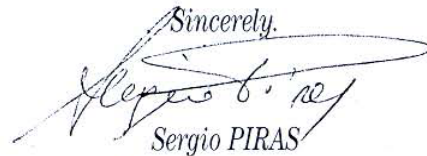

**Sergio PIRAS**

*Vice President and General Manager  
VARIAN Vacuum Technologies*

*Note: Fax or mail the Customer Request for Action (see backside page) to VARIAN Vacuum Technologies (Torino) - Quality Assurance or to your nearest VARIAN representative for onward transmission to the same address.*

**CUSTOMER REQUEST FOR CORRECTIVE / PREVENTIVE / IMPROVEMENT ACTION**

TO : VARIAN VACUUM TECHNOLOGIES TORINO - QUALITY ASSURANCE

FAX N° : XXXX - 011 - 9979350

ADDRESS: VARIAN S.p.A. - Via F.lli Varian, 54 - 10040 Leinì (Torino) - Italy

E-MAIL : marco.marzio@varianinc.com

NAME _____	COMPANY _____	FUNCTION _____
<p>ADDRESS : _____</p> <p>TEL. N° : _____ FAX N° : _____</p> <p>E-MAIL : _____</p>		
<p>PROBLEM / SUGGESTION :</p> <p>_____</p> <p>_____</p> <p>_____</p> <p>_____</p>		
<p>REFERENCE INFORMATION (model n°, serial n°, ordering information, time to failure after installation, etc.) :</p> <p>_____</p> <p>_____</p> <p>_____</p> <p style="text-align: right;">DATE _____</p>		

<p>CORRECTIVE ACTION PLAN / ACTUATION (by VARIAN VTT)</p> <p>_____</p> <p>_____</p> <p>_____</p> <p>_____</p> <p>_____</p>	<p>LOG N° _____</p>
--	---------------------

XXXX = Code for dialing Italy from your country ( es. 01139 from USA; 00139 from Japan, etc.)



ISTRUZIONI PER L'USO .....	1
GEBRAUCHSANLEITUNG .....	5
MODE D'EMPLOI .....	9
INSTRUCTIONS FOR USE .....	13
TECHNICAL INFORMATION .....	17
MINIVAC DESCRIPTION .....	17
CONTROLLER SPECIFICATIONS .....	19
CONTROLLER OUTLINE .....	20
INSTALLATION .....	21
Output Polarity Selection .....	21
Input/Output Interconnections .....	22
Pump Connection .....	22
OPERATION .....	23
Pressure Determination .....	23
Power Failure .....	23
Remote Control Mode Operation .....	23
MAINTENANCE .....	24
Troubleshooting .....	24
Controller Spares and Accessories .....	24
Controller to Vacion Pump Cables .....	24

## INFORMAZIONI GENERALI

Questa apparecchiatura è destinata ad uso professionale. L'utilizzatore deve leggere attentamente il presente manuale di istruzioni ed ogni altra informazione addizionale fornita dalla Varian prima dell'utilizzo dell'apparecchiatura. La Varian si ritiene sollevata da eventuali responsabilità dovute all'inosservanza totale o parziale delle istruzioni, ad uso improprio da parte di personale non addestrato, ad interventi non autorizzati o ad uso contrario alle normative nazionali specifiche. Il MiniVac è un alimentatore ad alta tensione e bassa potenza, utilizzato per alimentare le pompe ioniche.

Nei paragrafi seguenti sono riportate tutte le informazioni necessarie a garantire la sicurezza dell'operatore durante l'utilizzo dell'apparecchiatura. Informazioni dettagliate sono fornite nella sezione "Technical Information".

**Questo manuale utilizza le seguenti convenzioni:**



### PERICOLO!

I messaggi di pericolo attirano l'attenzione dell'operatore su una procedura o una pratica specifica che, se non eseguita in modo corretto, potrebbe provocare gravi lesioni personali.



### ATTENZIONE!

I messaggi di attenzione sono visualizzati prima di procedure che, se non osservate, potrebbero causare danni all'apparecchiatura.

### NOTA

Le note contengono informazioni importanti estrapolate dal testo.

## IMMAGAZZINAMENTO

Durante il trasporto e l'immagazzinamento dei MiniVac devono essere soddisfatte le seguenti condizioni ambientali:

- temperatura: da -20 °C a +70 °C
- umidità relativa: 0 - 95% (non condensante)

## PREPARAZIONE PER L'INSTALLAZIONE

Il controller viene fornito in un imballo protettivo speciale; se si presentano segni di danni, che potrebbero essersi verificati durante il trasporto, contattare l'ufficio vendite locale.

Durante l'operazione di disimballo, prestare particolare attenzione a non lasciar cadere il modulo e a non sottoporlo ad urti.

Non disperdere l'imballo nell'ambiente. Il materiale è completamente riciclabile e risponde alla direttiva CEE 85/399 per la tutela dell'ambiente.

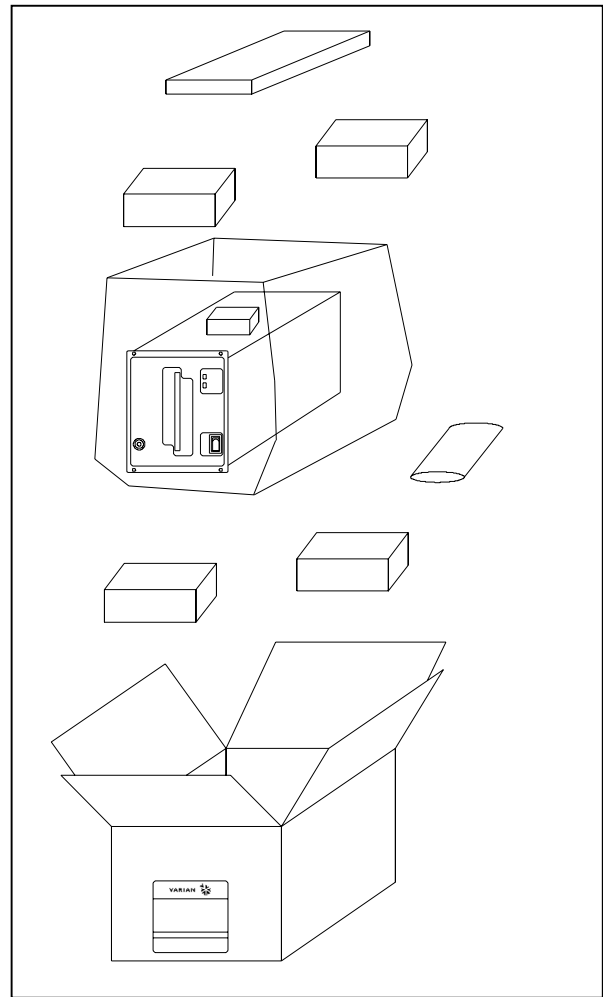

*Imballo dei controller*

Ogni controller giunge dalla Varian predisposto per una certa tensione di alimentazione:

- il modello 929-0196 FISCHER type High voltage connector.
- il modello 929-0197 KINGS type High voltage connector.

## INSTALLAZIONE



**PERICOLO!**

All'interno del controller si sviluppano alte tensioni che possono recare gravi danni o la morte. Prima di eseguire qualsiasi operazione di installazione o manutenzione del controller scollegarlo dalla presa di alimentazione.

### NOTA

Il controller deve essere installato all'interno di un apposito rack. In ogni caso occorre che l'aria di raffreddamento possa circolare liberamente intorno all'apparato. Non installare e/o utilizzare il controller in ambienti esposti ad agenti atmosferici (pioggia, gelo, neve), polveri, gas aggressivi, in ambienti esplosivi o con elevato rischio di incendio.

Durante il funzionamento è necessario che siano rispettate le seguenti condizioni ambientali:

- temperatura: da 0 °C a +45 °C
- umidità relativa: 0 - 95% (non condensante).

Per il collegamento del controller con la relativa pompa utilizzare il cavo specifico del controller stesso.

Per gli altri collegamenti e l'installazione degli accessori opzionali, vedere la sezione "Technical Information".

## USO

In questo paragrafo sono riportate le principali procedure operative. Per ulteriori dettagli e per procedure che coinvolgono collegamenti o particolari opzionali, fare riferimento al paragrafo "Use" della sezione "Technical Information".

Prima di usare il controller effettuare tutti i collegamenti elettrici e pneumatici e fare riferimento al manuale della pompa collegata.

## Comandi, Indicatori e Connettori del Controller

Di seguito sono illustrati sia il pannello frontale che quello posteriore con le interconnessioni.

Per maggiori dettagli fare riferimento alla sezione "Technical Information".

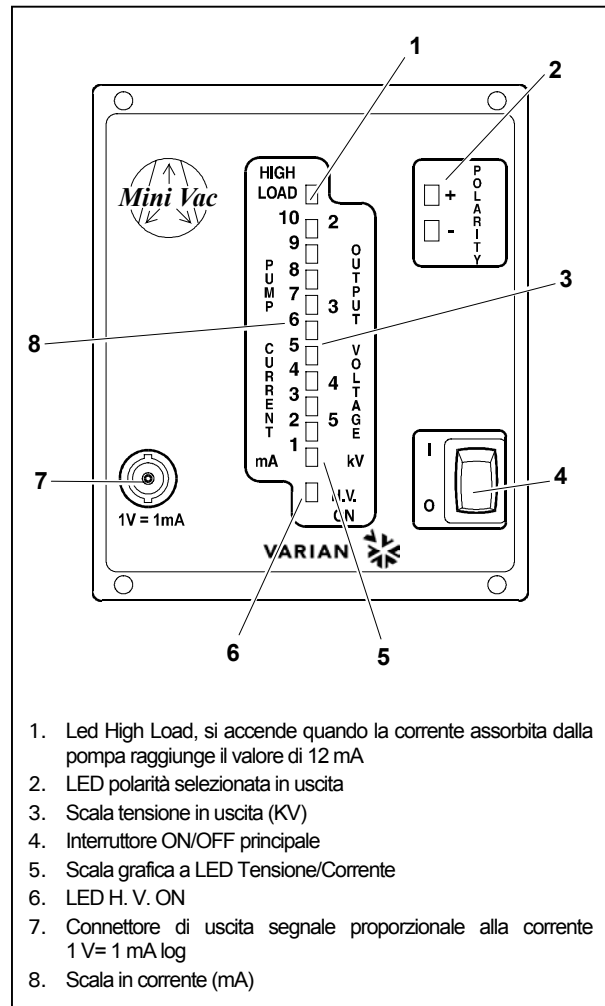

1. Led High Load, si accende quando la corrente assorbita dalla pompa raggiunge il valore di 12 mA
2. LED polarità selezionata in uscita
3. Scala tensione in uscita (KV)
4. Interruttore ON/OFF principale
5. Scala grafica a LED Tensione/Corrente
6. LED H. V. ON
7. Connettore di uscita segnale proporzionale alla corrente 1 V= 1 mA log
8. Scala in corrente (mA)

Pannello frontale del Controller

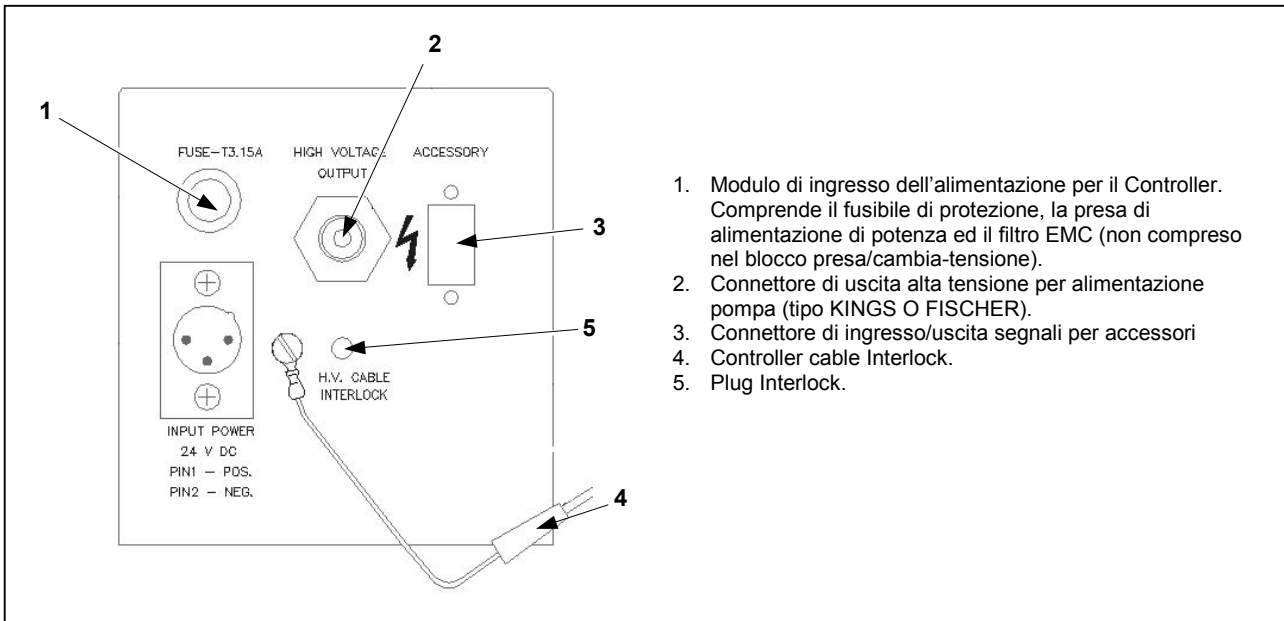

1. Modulo di ingresso dell'alimentazione per il Controller. Comprende il fusibile di protezione, la presa di alimentazione di potenza ed il filtro EMC (non compreso nel blocco presa/cambia-tensione).
2. Connettore di uscita alta tensione per alimentazione pompa (tipo KINGS O FISCHER).
3. Connettore di ingresso/uscita segnali per accessori
4. Controller cable Interlock.
5. Plug Interlock.

*Pannello posteriore dei Controller*

**PROCEDURE DI USO**

**Interlock**

L'Interlock è un dispositivo di sicurezza progettato dalla Varian per proteggere l'operatore dai gravi danni provocati dall'alta tensione presente sul connettore di alimentazione della pompa.

L'uso del controller è inteso con cavo alta tensione provvisto di Interlock.

Qualora il cliente voglia rinunciare, per applicazioni particolari, al cavo HV con interlock Si rende disponibile il cavo di interlock del controller (4).

**Avvio della pompa**

Per far partire la pompa è necessario:

1. Collegare la pompa al controller tramite l'apposito cavo HV.
2. Collegare l'Interlock del cavo HV al plug (5), se il cavo HV è sprovvisto del cavo di interlock collegare il cavo di interlock del controller (4) al plug (5).
3. Accendere il controller.

**Accensione del Controller**

Per accendere il controller portare l'interruttore principale in posizione ON dopo aver inserito il cavo di alimentazione nella presa di rete.

**Avvio della Pompa**

La pompa si avvia solo se il controller è acceso e la pompa è connessa al connettore di uscita. Per ulteriori informazioni fare riferimento alla sezione "Technical Information".

**Arresto della Pompa**

Per arrestare la pompa portare in posizione OFF l'interruttore principale posizionato sul pannello frontale.



**MANUTENZIONE**

I controller della serie MiniVac non richiedono alcuna manutenzione. Qualsiasi intervento deve essere eseguito da personale autorizzato.

In caso di guasto è possibile usufruire del servizio di riparazione Varian o del "Varian advance exchange service", che permette di ottenere un controller rigenerato in sostituzione di quello guasto.



**PERICOLO!**

Prima di effettuare qualsiasi intervento sul controller scollegare il cavo di alimentazione.

---

**NOTA**

*Il connettore di richiusura fornito con l'unità, ha i pin 3 e 7 cortocircuitati (Remote ON/OFF).*

*Per poter accendere l'HV è necessario montare questo connettore se non è connesso un contatto di Remote Interlock.*

---

**NOTA**

*L'unità è settata in fabbrica con polarità di uscita negativa. Per un eventuale cambio far riferimento al paragrafo "Output Polarity Selection".*

---

Qualora un controller dovesse essere rottamato, procedere alla sua eliminazione nel rispetto delle normative nazionali specifiche.

---

**SMALTIMENTO**

**Significato del logo "WEEE" presente sulle etichette.**

Il simbolo qui sotto riportato è applicato in ottemperanza alla direttiva CE denominata "WEEE". Questo simbolo (**valido solo per i paesi della Comunità Europea**) indica che il prodotto sul quale è applicato, NON deve essere smaltito insieme ai comuni rifiuti domestici o industriali, ma deve essere avviato ad un sistema di raccolta differenziata. Si invita pertanto l'utente finale a contattare il fornitore del dispositivo, sia esso la casa madre o un rivenditore, per avviare il processo di raccolta e smaltimento, dopo opportuna verifica dei termini e condizioni contrattuali di vendita.

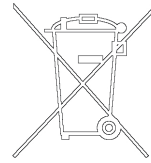

**ALLGEMEINES**

Dieser Apparat ist für Fachbetriebe bestimmt. Vor Gebrauch sollte der Benutzer dieses Handbuch sowie alle weiteren mitgelieferten Zusatzdokumentationen genau lesen. Bei - auch nur teilweiser - Nichtbeachtung der enthaltenen Hinweise, unsachgemäßem Gebrauch durch ungeschultes Personal, nicht autorisierten Eingriffen und Mißachtung der einheimischen, hier zur Geltung kommenden Bestimmungen übernimmt die Firma Varian keinerlei Haftung. Der MiniVac ist ein Hochspannungsnetzgerät niedriger Leistung, das zur Versorgung von Ionenpumpen verwendet wird.

In den folgenden Abschnitten sind alle erforderlichen Informationen für die Sicherheit des Bedieners bei der Anwendung des Geräts aufgeführt. Detaillierte technische Informationen sind im Anhang "Technical Information" enthalten.

**In dieser Gebrauchsanleitung werden Sicherheitshinweise folgendermaßen hervorgehoben:**



**GEFAHRI!**

Die Gefahrenhinweise lenken die Aufmerksamkeit des Bedieners auf eine bestimmte Prozedur oder Praktik, die bei unkorrekter Ausführung schwere Verletzungen hervorrufen können.



**ACHTUNG!**

Die Die Warnhinweise vor bestimmten Prozeduren machen den Bediener darauf aufmerksam, daß bei Nichteinhaltung Schäden an der Anlage entstehen können.

**ANMERKUNG**

*Die Anmerkungen enthalten wichtige Informationen, die aus dem Text hervorgehoben werden.*

**LAGERUNG**

Beim Transport und bei der Lagerung der Controller müssen folgende klimatische Verhältnisse eingehalten werden:

- Temperatur: von -20 °C bis +70 °C
- Relative Luftfeuchtigkeit: 0-95 % (nicht kondensierend)

**VOR DER INSTALLATION**

Der Controller wird mit einer speziellen Schutzverpackung geliefert. Eventuelle Transportschäden müssen der zuständigen örtlichen Verkaufsstelle gemeldet werden. Beim Auspacken vorsichtig vorgehen, damit der Controller nicht fällt oder Stößen ausgesetzt wird. Das Verpackungsmaterial muß korrekt entsorgt werden. Es ist vollständig recyclebar und entspricht der EG-Richtlinie 85/399 für Umweltschutz.

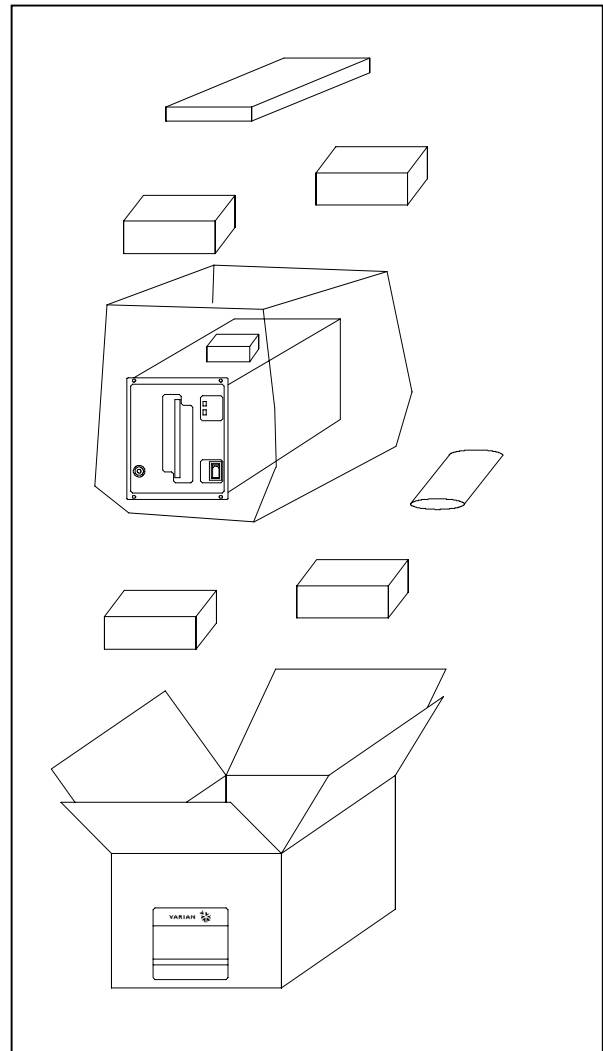

*Verpackung der Controller*

Alle Varian-Controller sind für eine bestimmte Anschlußspannung ausgelegt:

- das Modell 929-0196 FISCHER type High voltage connector.
- das Modell 929-0197 KINGS type High voltage connector.

**INSTALLATION**



**GEFAHR!**

Im Inneren des Controllers entstehen hohe Spannungen, die schwere Schäden verursachen und lebensgefährlich sein können. Vor jedem Montage- bzw. Wartungseingriff muß deshalb der Netzstecker gezogen werden.

**ANMERKUNG**

Der Controller kann auf einen Tisch oder ein Gestell montiert werden. In beiden Fällen muß auf die ungehinderte Zirkulation der Kühlluft im Bereich des Geräts geachtet werden.

Der Controller darf nicht in Umgebungen installiert u/o benutzt werden, die Witterungseinflüssen (Regen, Frost, Schnee), Staub und aggressiven Gasen ausgesetzt sind und in denen Explosions- und erhöhte Brandgefahr besteht.

Beim Betrieb müssen folgende Umgebungsbedingungen eingehalten werden:

- Temperatur: von +0 °C bis +45 °C
- Relative Luftfeuchtigkeit: 0 - 95 % (nicht kondensierend).

Für den Anschluß des Controllers an die Pumpe muß das zum Controller gehörende Kabel benutzt werden.

Andere Anschlüsse und die Installation optionalen Zubehörs ist im Abschnitt "Technical Information" beschrieben.

**GEBRAUCH**

In diesem Kapitel sind die wichtigsten Betriebsvorgänge aufgeführt. Für weitere Hinweise bezüglich Anschlüsse und Montage des bestellbaren Zubehörs siehe Kapitel "Use" im Anhang zu "Technical Information".

Vor Benutzung des Controllers sämtliche elektrischen und pneumatischen Anschlüsse ausführen, und die Betriebsanleitung der angeschlossenen Pumpe durchlesen.

**Steuerungen, Anzeigen und Anschlüsse des Controllers**

Nachstehend werden das Bedienfeld des Controllers sowie die Anschlußfelder beschrieben.

Für weitere Einzelheiten siehe "Technical Information".

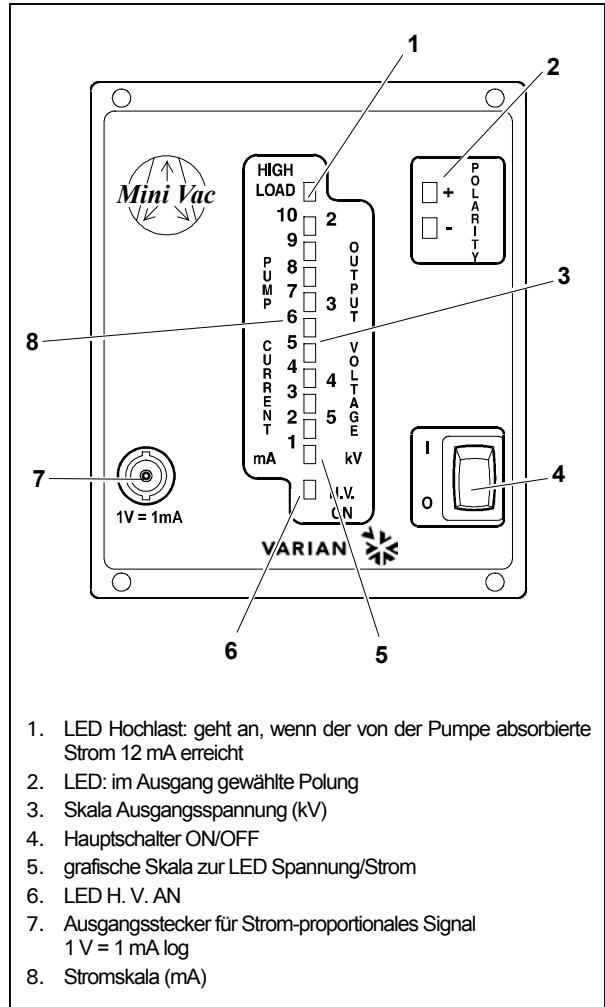

1. LED Hochlast: geht an, wenn der von der Pumpe absorbierte Strom 12 mA erreicht
2. LED: im Ausgang gewählte Polung
3. Skala Ausgangsspannung (kV)
4. Hauptschalter ON/OFF
5. grafische Skala zur LED Spannung/Strom
6. LED H. V. AN
7. Ausgangsstecker für Strom-proportionales Signal  
1 V = 1 mA log
8. Stromskala (mA)

*Bedienfeld der Controller*

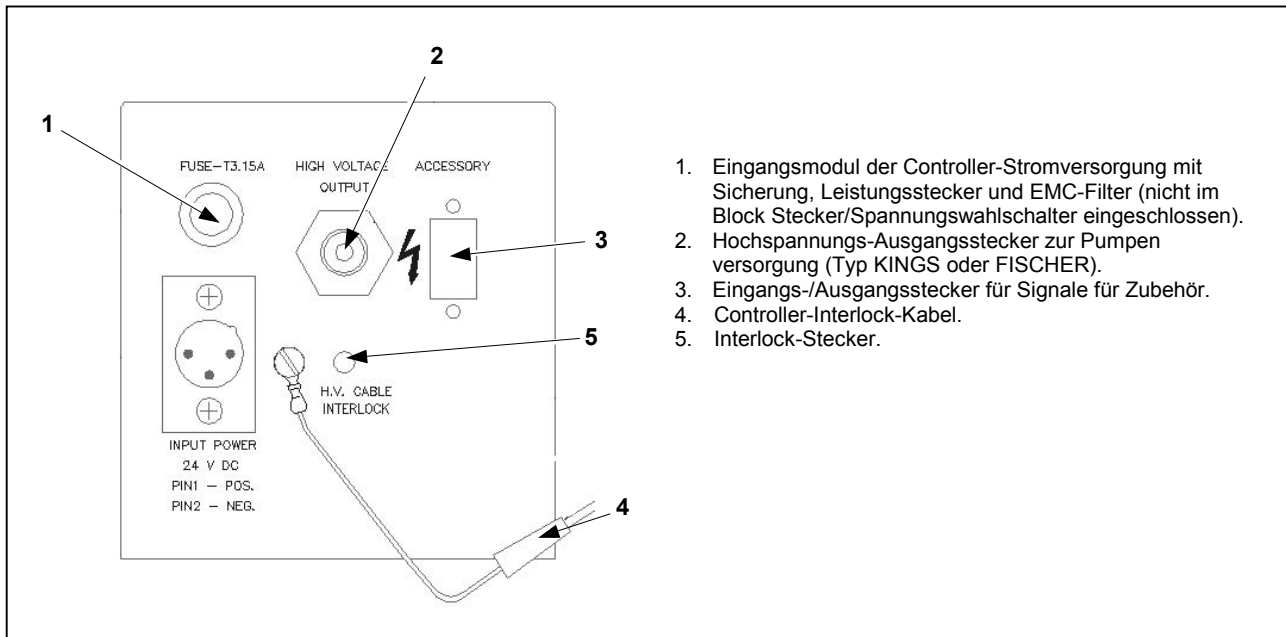

1. Eingangsmodul der Controller-Stromversorgung mit Sicherung, Leistungsstecker und EMC-Filter (nicht im Block Stecker/Spannungswahlschalter eingeschlossen).
2. Hochspannungs-Ausgangsstecker zur Pumpenversorgung (Typ KINGS oder FISCHER).
3. Eingangs-/Ausgangsstecker für Signale für Zubehör.
4. Controller-Interlock-Kabel.
5. Interlock-Stecker.

Rücktafel der Controller

## BEDIENUNG

### Interlock

Interlock ist eine von Varian entworfene Sicherheitsvorrichtung, um den Bediener vor schweren Schäden zu schützen, die durch die Hochspannung am Stromversorgungsstecker der Pumpe hervorgerufen werden können.

Der Controller muss mit dem Hochspannungskabel mit Interlock zum Einsatz kommen.

Falls der Auftraggeber bei besonderen Verwendungen auf das Hochspannungskabel mit Interlock verzichten wollen sollte, kann das Interlock-Kabel des Controllers (4) verwendet werden.

### Inbetriebnahme der Pumpe

Um die Pumpe zu starten, müssen vorher folgende Schritte durchgeführt werden:

1. Mit Hilfe des dafür vorgesehenen Hochspannungskabels die Pumpe an den Controller anschließen
2. Interlock des Hochspannungskabels mit dem Stecker (5) verbinden, falls das Hochspannungskabel keinen Interlock haben sollte, das Interlock-Kabel des Controllers (4) mit dem Stecker (5) verbinden.
3. Controller einschalten.

### Einschalten des Controllers

Zum Einschalten des Controllers genügt es, das Netzkabel an die Steckdose anzuschließen.

### Pumpenstart

Die Pumpe startet nur, wenn der Controller eingeschaltet und die Pumpe am Ausgangsstecker angeschlossen ist. Weitere Informationen finden sich im Abschnitt "Technical Information".

### Pumpenstopp

Zum Stoppen der Pumpe muß der Hauptschalter auf dem Bedienfeld auf OFF gesetzt werden.

### WARTUNG

Die Controller der MiniVac Serie brauchen keinerlei Wartung. Alle Eingriffe dürfen nur von autorisiertem Personal vorgenommen werden.

Bei Defekten kann der Reparatur Service von Varian oder der "Varian Advance Exchange Service" in Anspruch genommen werden, der den defekten Controller durch ein Austauschgerät ersetzt.



**GEFAHR!**

Vor jedem Eingriff am Controller muß der Netzstecker gezogen werden.

---

### ANMERKUNG

*Bei dem mit der Einheit gelieferte Abschluss-Stecker sind die Stifte 3 und 7 kurzgeschlossen (Remote ON/OFF).*

*Falls kein Remote Interlock Kontakt angeschlossen ist, kann die Hochspannung nur angeschaltet werden, wenn dieser Stecker montiert ist.*

---

### ANMERKUNG

*Fabrikseitig ist die Einheit mit negativer Ausgangspolung eingestellt. Soll das geändert werden, den Absatz "Output Polarity Selection" zu Rate ziehen.*

---

Eine eventuelle Verschrottung muß unter Einhaltung der einschlägigen landesüblichen Vorschriften erfolgen.

---

### ENTSORGUNG

#### **Bedeutung des "WEEE" Logos auf den Etiketten.**

Das folgende Symbol ist in Übereinstimmung mit der EU-Richtlinie WEEE (Waste Electrical and Electronic Equipment) angebracht.

Dieses Symbol (**nur in den EU-Ländern gültig**) zeigt an, dass das betreffende Produkt nicht zusammen mit Haushaltsmüll entsorgt werden darf sondern einem speziellen Sammelsystem zugeführt werden muss.

Der Endabnehmer sollte daher den Lieferanten des Geräts - d.h. die Muttergesellschaft oder den Wiederverkäufer - kontaktieren, um den Entsorgungsprozess zu starten, nachdem er die Verkaufsbedingungen geprüft hat.

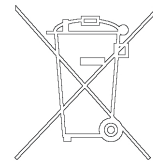

**INDICATIONS GENERALES**

Cet appareillage a été conçu en vue d'une utilisation professionnelle. L'utilisateur doit lire attentivement cette notice d'instructions ainsi que toute autre indication supplémentaire fournie par Varian, avant l'utilisation de l'appareil. Varian décline toute responsabilité quant à: non-respect total ou partiel des instructions pour l'utilisation, mauvais usage par du personnel non formé, opérations non autorisées usage contraire aux réglementations nationales spécifiques.

MiniVac est un alimentateur à haute tension, faible puissance, conçu pour alimenter les pompes ioniques.

Les paragraphes suivants donnent toutes les indications nécessaires pour garantir la sécurité de l'opérateur pendant l'utilisation de l'appareillage. Des renseignements plus détaillés se trouvent dans la section "Technical Information".

Cette notice utilise les signes conventionnels suivants:



**DANGER!**

Les messages de danger attirent l'attention de l'opérateur sur une procédure ou une manoeuvre spéciale qui, si elle n'est pas effectuée correctement, risque de provoquer de graves lésions.



**ATTENTION!**

Les messages d'attention apparaissent avant certaines procédures qui, si elles ne sont pas observées, pourraient endommager sérieusement l'appareillage.

**NOTE**

*Les notes contiennent des renseignements importants, isolés du texte.*

**EMMAGASINAGE**

Pendant le transport et l'emmagasinage des Mini Vac contrôleurs, il faudra veiller à respecter les conditions environnementales suivantes:

- Température: de - 20 °C à + 70 °C
- Humidité relative: 0 - 95% (non condensante).

**PREPARATION POUR L'INSTALLATION**

Le contrôleur est fourni dans un emballage de protection spécial; si vous constatez des marques de dommages pouvant s'être produits pendant le transport, adressez-vous aussitôt au bureau de vente local. Pendant l'opération d'ouverture de l'emballage, veiller tout particulièrement à ne pas laisser tomber le contrôleur et à ne lui faire subir aucun choc. Ne pas jeter l'emballage dans la nature. Le matériel est entièrement recyclable et il est conforme à la directive CEE 83/399 en matière de protection de l'environnement.

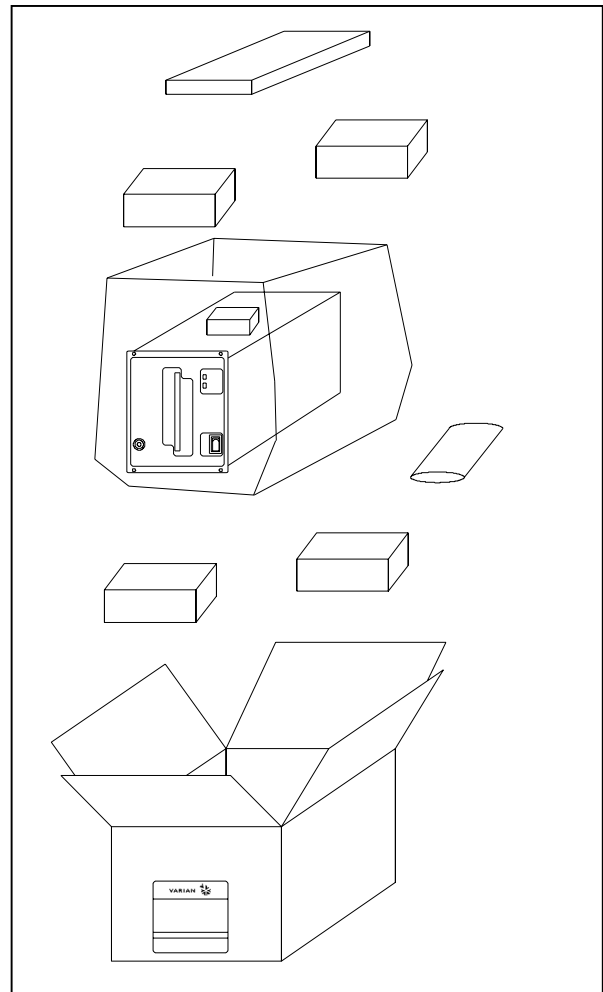

*Emballage des Contrôleurs*

Chaque contrôleur est fourni par Varian prééquipé pour une certaine tension d'alimentation:

- modèle 929-0196 FISCHER type High voltage connector.
- modèle 929-0197 KINGS type High voltage connector.

## INSTALLATION



**DANGER!**

A l'intérieur du contrôleur se développent de hautes tensions qui peuvent provoquer de graves dommages et même la mort. Avant d'effectuer toute opération d'installation ou d'entretien du contrôleur, le débrancher de la prise d'alimentation.

### NOTE

Le contrôleur doit être installé dans une baie prévue à cet effet. Il est en tout cas nécessaire que l'air de refroidissement puisse circuler librement à l'intérieur de l'appareil. Ne pas installer et/ou utiliser le contrôleur dans des milieux exposés aux agents atmosphériques (pluie, gel, neige), aux poussières, aux gaz de combat ni dans des milieux explosifs ou à risque élevé d'incendie.

Pendant le fonctionnement, il est nécessaire de respecter les conditions environnementales suivantes:

- Température: 0 °C à + 45 °C
- Humidité relative: 0 - 95% (non condensante).

Pour la connexion du contrôleur à la pompe correspondante, utiliser le câble du contrôleur prévu à cet effet.

Pour les autres connexions et pour l'installation des accessoires en option, voir la section "Technical Information".

## UTILISATION

Ce paragraphe décrit les principales procédures de fonctionnement. Pour tout autre complément d'information et pour les procédures concernant des connexions ou des éléments en option, se reporter au paragraphe "Use" de la section "Technical Information".

Avant d'utiliser le contrôleur, effectuer toutes les connexions électriques et pneumatiques et se référer à la notice de la pompe connectée.

## Commandes, Indicateurs et Connecteurs du Contrôleur

La figure ci-après représente le tableau de commande du Contrôleur et les tableaux d'interconnexion.

Pour de plus amples détails, se reporter à la section "Technical Information".

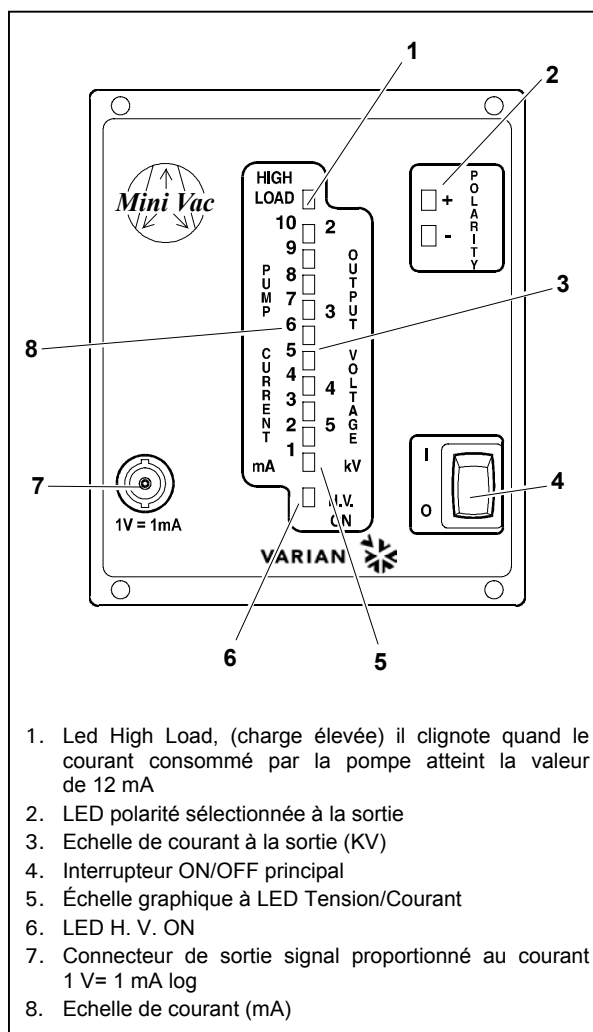

1. Led High Load, (charge élevée) il clignote quand le courant consommé par la pompe atteint la valeur de 12 mA
2. LED polarité sélectionnée à la sortie
3. Echelle de courant à la sortie (KV)
4. Interrupteur ON/OFF principal
5. Échelle graphique à LED Tension/Courant
6. LED H. V. ON
7. Connecteur de sortie signal proportionné au courant 1 V= 1 mA log
8. Echelle de courant (mA)

Tableau avant du Contrôleur



Tableau arrière des Contrôleurs

## PROCEDURES D'UTILISATION

### Interlock

L'interlock est un dispositif de sécurité conçu par Varian pour protéger l'opérateur contre les sérieux dommages provoqués par la présence de haute tension au niveau du connecteur d'alimentation de la pompe.

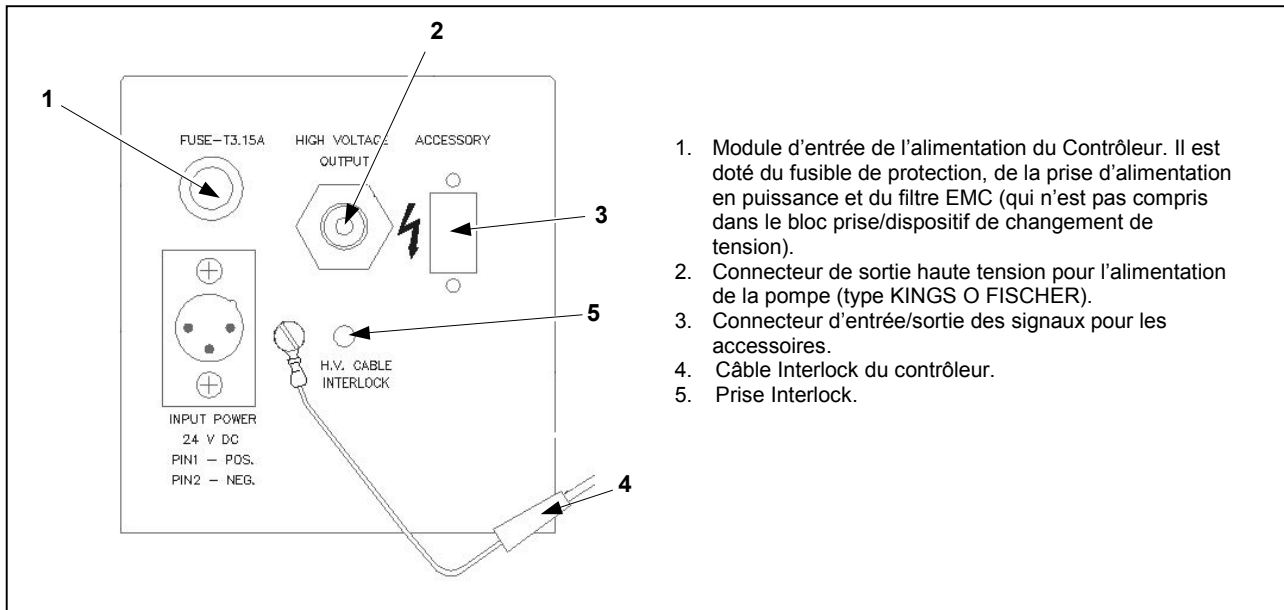
Il est entendu que le câble de haute tension du contrôleur est équipé de l'Interlock.

Si le client ne souhaite pas utiliser le câble HV avec interlock sur certaines installations, le câble d'interlock du contrôleur (4) est disponible.

### Démarrage de la pompe

Pour mettre la pompe en marche, il faut :

1. Relier la pompe au contrôleur à l'aide du câble HV réservé à cet effet.
2. Brancher l'Interlock du câble HV sur la prise (5) ; si le câble HV n'est pas équipé du câble d'interlock, brancher le câble d'interlock du contrôleur (4) sur la prise (5).
3. Allumer le contrôleur.

### Mise sous tension du Contrôleur

Pour mettre le contrôleur sous tension, il suffit de mettre l'interrupteur principal sur ON après avoir branché le câble d'alimentation sur la prise du réseau.

### Mise en marche de la Pompe

La pompe démarre uniquement si le contrôleur est allumé et la pompe est reliée au connecteur de sortie. Pour d'ultérieurs renseignements se référer à la section "Technical Information".

### Arrêt de la Pompe

Pour arrêter la pompe, mettre l'interrupteur principal situé sur le tableau avant sur OFF.



**ENTRETIEN**

Les contrôleurs de la série MiniVac ne requièrent aucun entretien. Toute intervention doit être effectuée par du personnel autorisé.

En cas de panne, il est possible de faire appel au service de réparation Varian ou au "Varian advance exchange service", qui permet d'obtenir un contrôleur régénéré à la place de celui en panne.



**DANGER!**

Avant d'effectuer toute intervention sur le contrôleur, débrancher le câble d'alimentation.

**NOTE**

*Le connecteur de fermeture fourni avec l'unité a les pins 3 et 7 en court circuit (Remote ON/OFF).*

*Pour pouvoir allumer l'HV il faut monter ce connecteur si un contact de Remote Interlock n'est pas branché.*

**NOTE**

*L'unité est assignée à l'usine avec polarité de sortie négative. Pour un changement éventuel, se référer au paragraphe "Output Polarity Selection".*

Si un contrôleur doit être mis au rebut l'éliminer conformément aux réglementations nationales en la matière.

**MISE AU REBUT**

**Signification du logo "WEEE" figurant sur les étiquettes.**

Le symbole ci-dessous est appliqué conformément à la directive CE nommée "WEEE".

Ce symbole (**uniquement valide pour les pays de la Communauté européenne**) indique que le produit sur lequel il est appliqué NE doit PAS être mis au rebut avec les ordures ménagères ou les déchets industriels ordinaires, mais passer par un système de collecte sélective. Après avoir vérifié les termes et conditions du contrat de vente, l'utilisateur final est donc prié de contacter le fournisseur du dispositif, maison mère ou revendeur, pour mettre en œuvre le processus de collecte et mise au rebut.

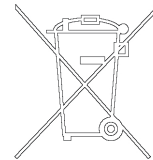

**GENERAL INFORMATION**

This equipment is destined for use by professionals. The user should read this instruction manual and any other additional information supplied by Varian before operating the equipment. Varian will not be held responsible for any events occurring due to non-compliance, even partial, with these instructions, improper use by untrained persons, non-authorized interference with the equipment or any action contrary to that provided for by specific national standards. The MiniVac is a high voltage and low power feeder used to feed the ionic pumps.

The following paragraphs contain all the information necessary to guarantee the safety of the operator when using the equipment. Detailed information is supplied in the section "Technical Information".

This manual uses the following standard protocol:



**WARNING!**

The warning messages are for attracting the attention of the operator to a particular procedure or practice which, if not followed correctly, could lead to serious injury.



**CAUTION!**

The caution messages are displayed before procedures which, if not followed, could cause damage to the equipment.

**NOTE**

The notes contain important information taken from the text.

**STORAGE**

When transporting and storing the MiniVacs, the following environmental requirements should be satisfied:

- temperature: from -20 °C to + 70 °C
- relative humidity: 0 - 95%  
(without condensation)

**PREPARATION FOR INSTALLATION**

The controller is supplied in a special protective packing. If this shows signs of damage which may have occurred during transport, contact your local sales office. When unpacking, ensure that the module is not dropped or subjected to any form of impact. Do not dispose of the packing materials in an unauthorised manner. The material is 100% recyclable and complies with EEC Directive 85/399.

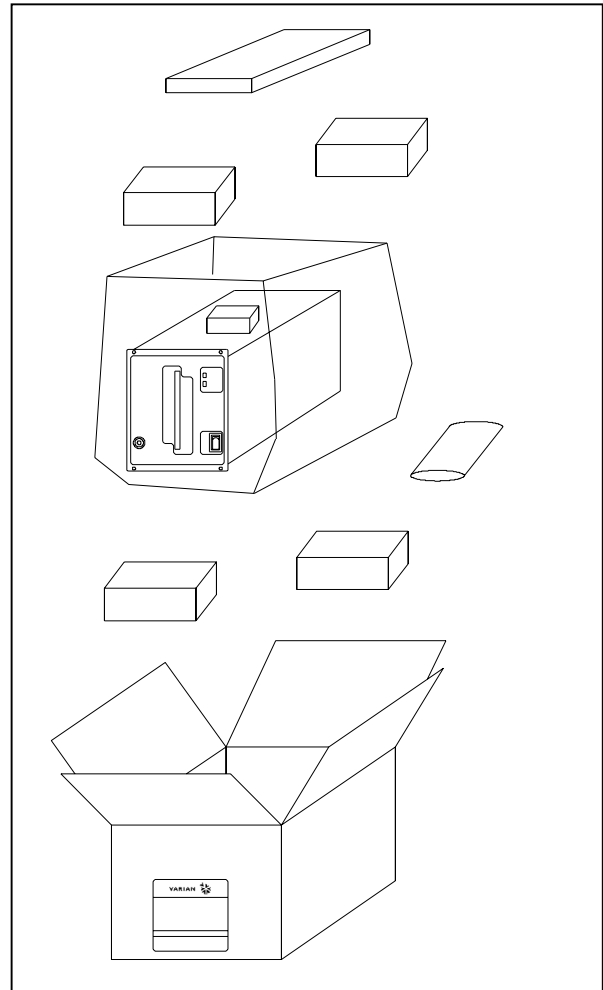

*Controller Packing*

Each controller is factory set for a specific power supply:

- Model 929-0196 FISCHER type High voltage connector.
- Model 929-0197 KINGS type High voltage connector.

**INSTALLATION**



**WARNING!**

High voltage developed in the controller can cause severe injury or death. Before servicing the unit, disconnect the input power cable.

**NOTE**

The controller must be installed inside a rack module, but it must be positioned so that free air can flow through the holes. Do not install or use the controller in an environment exposed to atmospheric agents (rain, snow, ice), dust, aggressive gases, or in explosive environments or those with a high fire risk.

During operation, the following environmental conditions must be respected:

- temperature: from 0 °C to +45 °C
- relative humidity: 0 - 95% (without condensation)

To connect the controller to the pump use the specific cable supplied with the controller.

See the section "Technical Information" for detailed information about the above mentioned and the other connections, and about the options installation.

**USE**

This paragraph describes the fundamental operating procedures. Detailed information and operating procedures that involve optional connections or options are supplied in the paragraph "USE" of the section "Technical Information".

Make all vacuum manifold and electrical connections and refer to the pump instruction manual prior to operating the controller.

**Controller Controls, Indicators and Connectors**

The following paragraph illustrates either the front and rear panel with its interconnections.

More details are contained in the appendix "Technical Information".

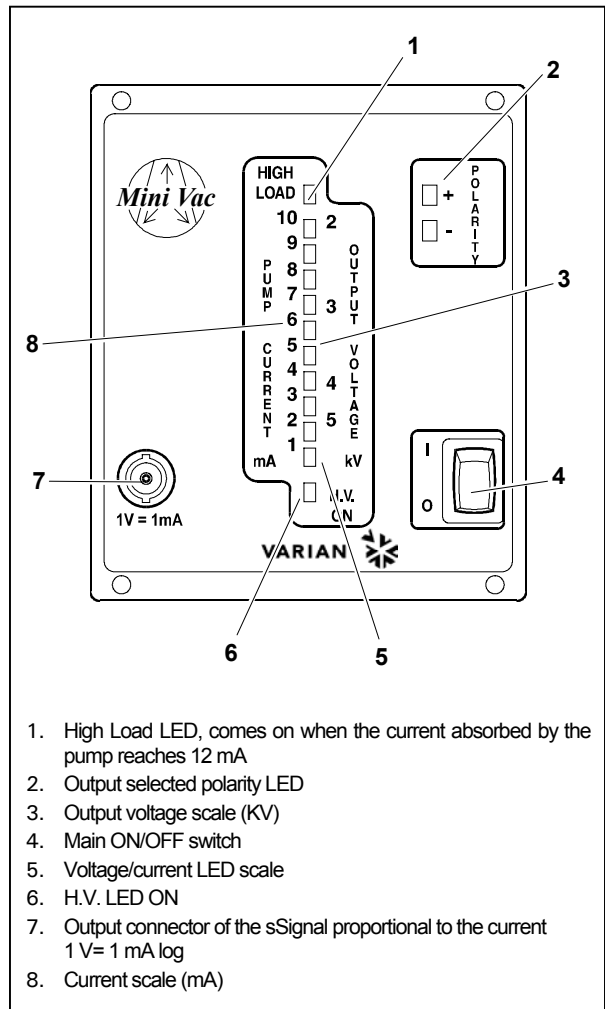

1. High Load LED, comes on when the current absorbed by the pump reaches 12 mA
2. Output selected polarity LED
3. Output voltage scale (KV)
4. Main ON/OFF switch
5. Voltage/current LED scale
6. H.V. LED ON
7. Output connector of the sSignal proportional to the current 1 V= 1 mA log
8. Current scale (mA)

Controller Front Panel

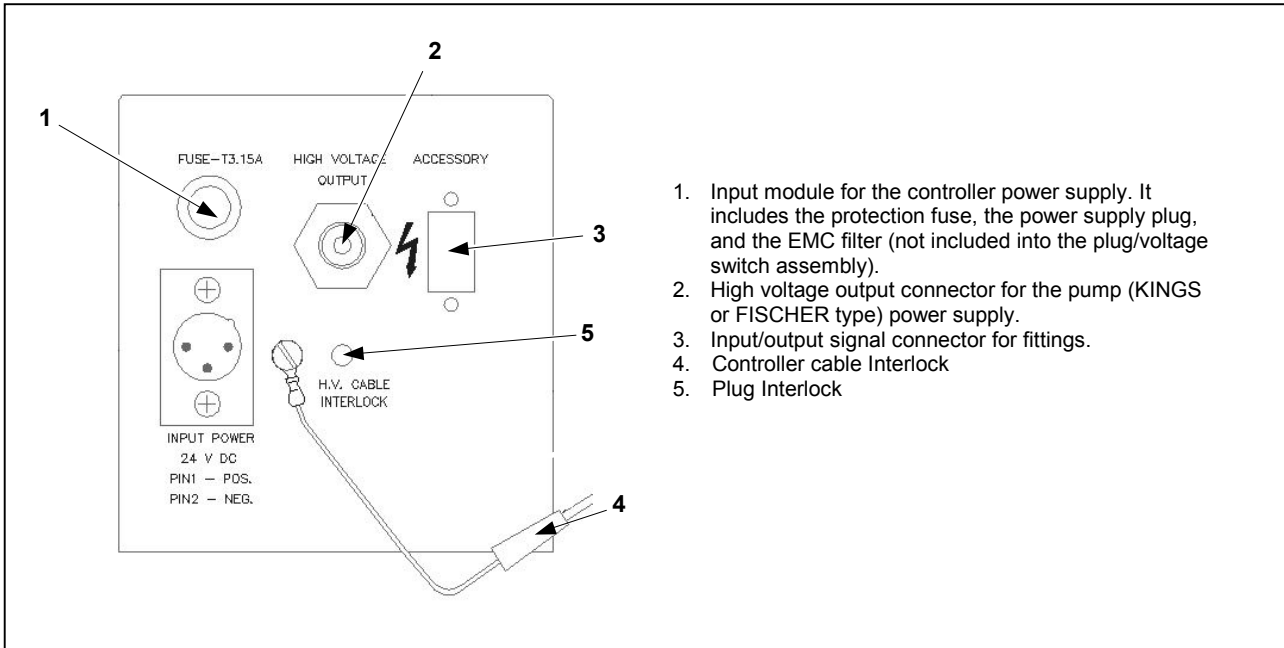

Controller Rear Panel

**USE PROCEDURE**

**Interlock**

The Interlock is a safety device designed by Varian to protect the operator against serious injury caused by the high voltage present on the pump power connector. The controller is intended to be used with a HV cable furnished with Interlock. If the customer does not wish to use the HV cable with interlock for particular application requirements, the interlock cable of the controller (4) is available.

**Start-up of the pump**

To start the pump:

1. Connect the pump to the controller using the specific HV cable.
2. Connect the Interlock of the HV cable to the plug (5); if the HV cable is without the interlock cable, connect the interlock cable of the controller (4) to the plug (5).
3. Switch on the controller.

**Controller Start-up**

To start-up the controller, turn the main switch to ON, after plugging the power cable into a suitable power source.

**Starting the Pump**

The pump is activated only if the controller is powered on and the pump itself is connected to the output connector. For further information refer to the "Technical Information" section.

**Pump Shutdown**

To shutdown the pump, turn the main switch placed on the front panel to OFF.

**MAINTENANCE**

The MiniVac series controllers do not require any maintenance interventions. Any intervention must be performed by authorised personnel only.

When a fault has occurred it is possible to use the Varian repair service or the “Varian advance exchange service”, that allows to obtain a regenerated controller replacing the faulty one.



**WARNING!**

Before carrying out any work on the controller, disconnect it from the supply.

---

**NOTE**

*Pins 3 and 7 on the loopback plug provided with the unit are short circuited (Remote ON/OFF). This loopback plug must be fitted to power on the HV unless a Remote/Interlock contact is connected.*

---

**NOTE**

*The unit is factory set with a negative output polarity. Refer to the section “Output Polarity Selection” for instructions on how to change the output polarity.*

---

If a pump is to be scrapped, it must be disposed of in accordance with the specific national standards.

---

**DISPOSAL**

**Meaning of the "WEEE" logo found in labels**

The following symbol is applied in accordance with the EC WEEE (Waste Electrical and Electronic Equipment) Directive.

This symbol (**valid only in countries of the European Community**) indicates that the product it applies to must NOT be disposed of together with ordinary domestic or industrial waste but must be sent to a differentiated waste collection system.

The end user is therefore invited to contact the supplier of the device, whether the Parent Company or a retailer, to initiate the collection and disposal process after checking the contractual terms and conditions of sale.

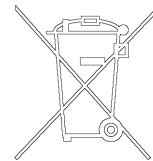

**MINIVAC DESCRIPTION**

The MiniVac controller is a quarter rack solid state power supply with self protection features, which generates high voltage using high frequency switching technology.

The MiniVac ion pump controller is designed to operate any type of ion pumps: Diode, Differential Diode, Triode and StarCell.

The MiniVac controller is a very compact and light unit capable of powering any size of pump at different operating pressure.

Small pumps (up to 8 l/s) can be operated at any pressure up to  $1 \times 10^{-3}$  mbar.

Medium pumps (20 l/s to 60 l/s) can be operated at any pressure up to  $1 \times 10^{-5}$  mbar/Torr (continuous operation).

Large pumps (120 l/s to 400 l/s) can be operated at any pressure up to  $2 \times 10^{-6}$  mbar/Torr (continuous operation).

Medium/larger ion pumps must first be started with an appropriate control unit and pumped to a sufficiently low pressure where the current demand is below 8 mA.

The MiniVac controller is designed to withstand continuous operation at short circuit condition, without any damage to the ion pump or to the controller itself.

The MiniVac controller is available in two versions, which differ in the high voltage output connector type.

- Model 929-0196 FISCHER type High voltage connector
- Model 929-0197 KINGS type High voltage connector

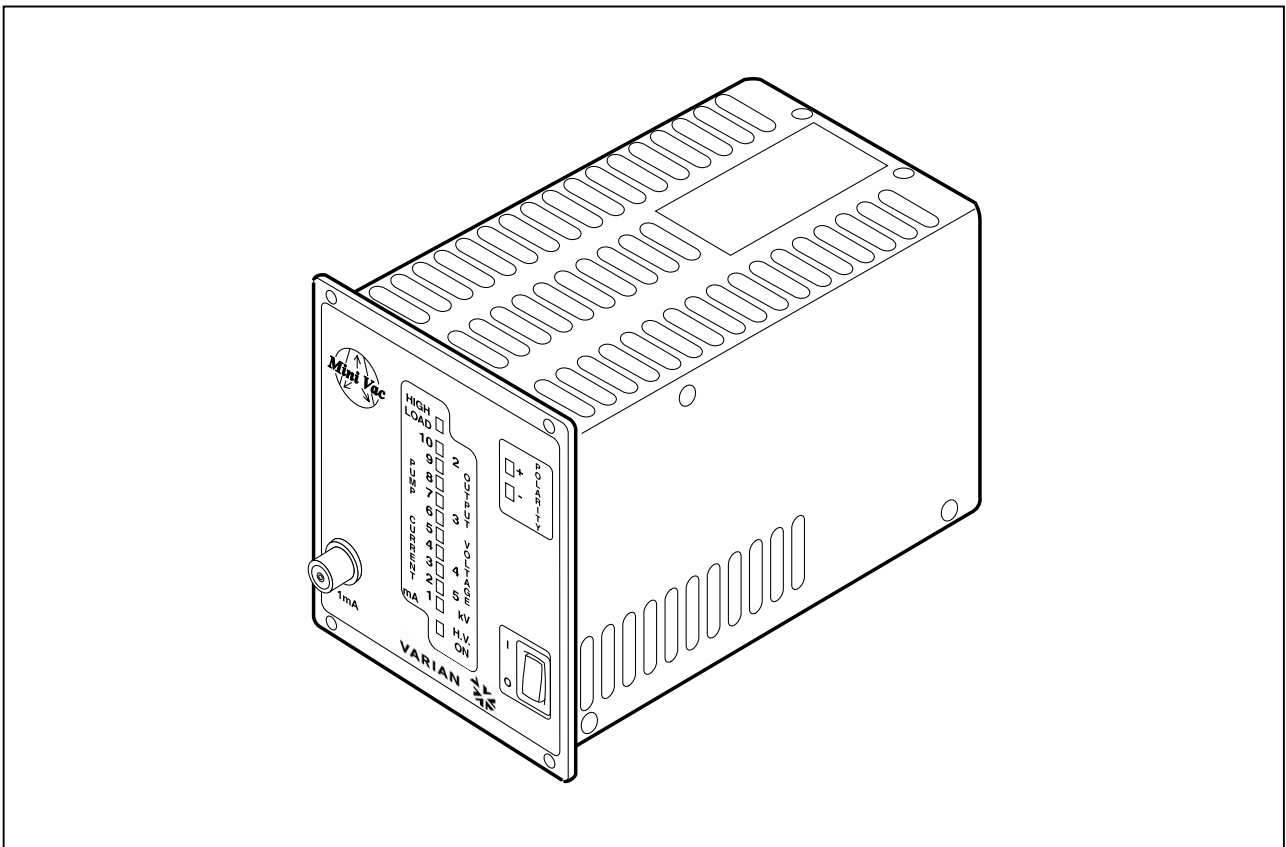

*MiniVac Controllers*

The MiniVac controller front panel controls are shown in the following figure.

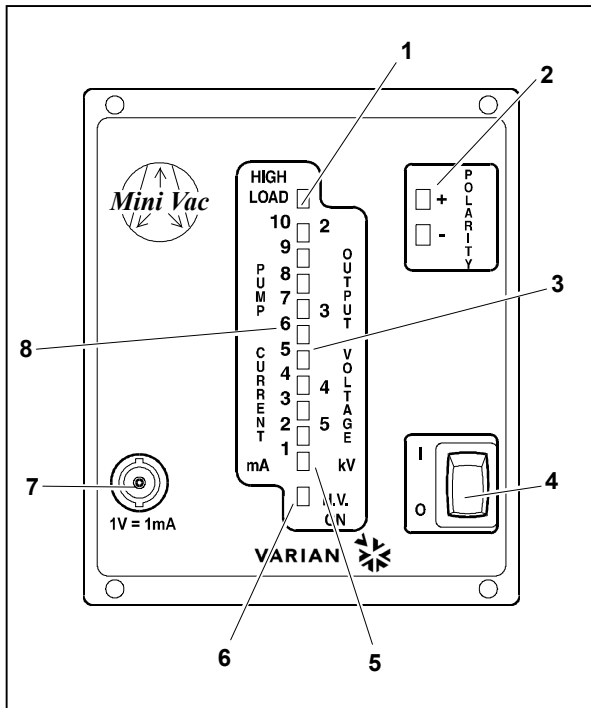

MiniVac Front Panel Controls

1. High Load LED lights up when the pump current is higher than 12 mA.
2. Output polarity LEDs selection indicators.
3. Voltage output scale (kV).
4. Controller power ON/OFF switch.
5. Current/voltage LED's bar graph indicator.
6. H. V. ON LED.
7. Recorder output connector.
8. Pump current scale (mA).

The MiniVac controller rear panel controls are shown in the following figure.

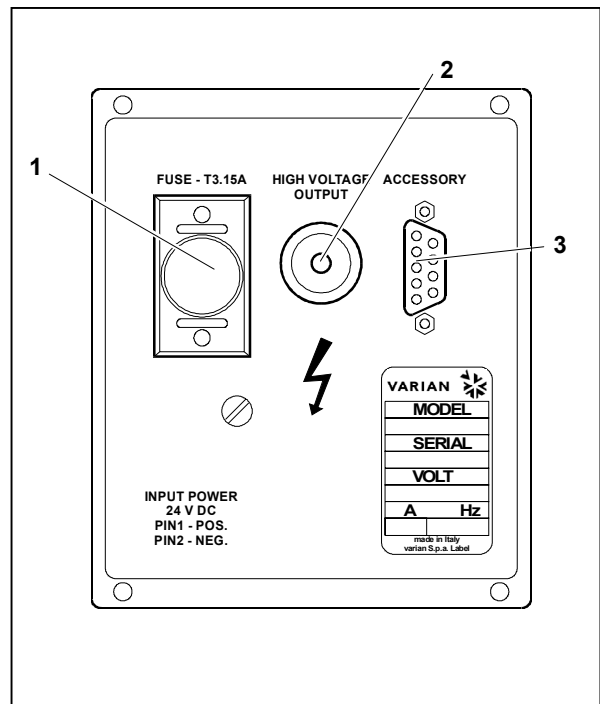

MiniVac Controller Rear Panel Controls

1. Controller power entry module.
2. High voltage output connector (KINGS or FISCHER type).
3. Accessory connector for input/output signals.

**CONTROLLER SPECIFICATIONS**

Operation	All type and size of Vaclon pump
Input:	
- Voltage	24 Vdc $\pm$ 4 Vdc
- Power	60 W
- Fuse	2 x T 3.15 A
Output:	
- Voltage	$\pm$ 5000 Vdc $\pm$ 10% (refer to the following figure) (polarity through internal card)
- Current	15 mA (short circuit) (refer to the following figure)
- Power	21 W
Dual Current Recorder Output:	
- Rec Out1	0 to 10 Vdc (10 V correspond to 10 mA); resolution of 10 mV minimum (corresponding to 10 $\mu$ A) Available on front panel BNC connector and at pins 1 and 6 of rear panel Accessory connector.
- Rec Out2	0 to 10 Vdc (10 V correspond to 1 mA); resolution of 10 mV minimum (corresponding to 1 $\mu$ A) Available at pins 2 and 6 of rear panel Accessory connector.

Voltage Recorder Output:	
- Rec Out	0 to 5 V (corresponding to 0 to 5 kV with 1 V corresponding to 1 kV in linear mode) Available at pins 4 and 8 of rear panel Accessory connector.
Operating temperature	0 °C to 45 °C
Storage temperature	-20 °C to +70 °C
Radio interference suppression	EN 55011 class A Group 1 EN 61000-4-2 EN 61000-4-4 EN 61000-4-3
Safety	EN 61010-1
Installation category	II
Pollution degree	2
Output connector:	FISCHER type: part number 105 A049 for model 929-0196 KINGS type: part number 1064-1 for model 929-0197
- High voltage	J 001 input/output signal (9-pin "D" type socket)
- Accessory	
Weight	1.3 Kg    2.86 lbs



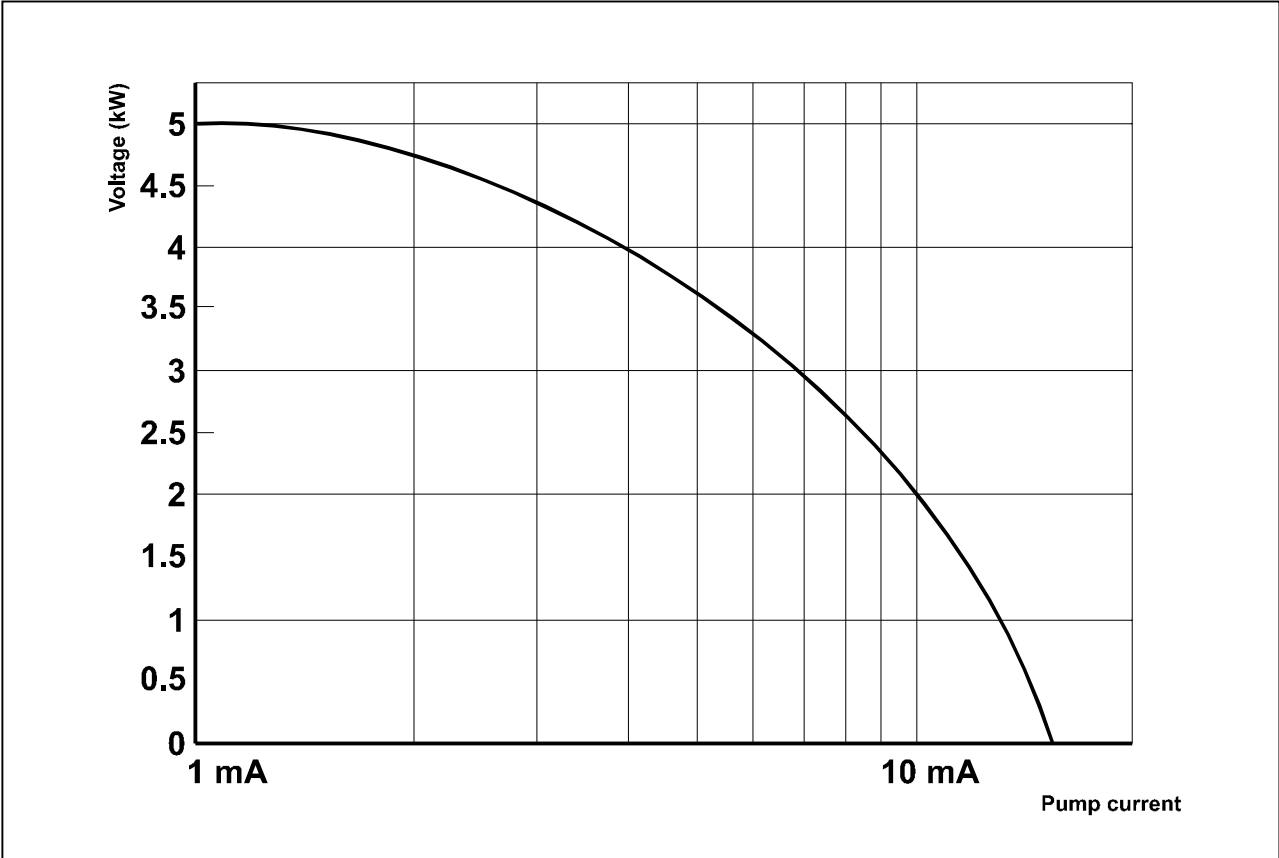

Voltage Vs Current Diagram

**CONTROLLER OUTLINE**

The outline dimensions of the MiniVac controller are shown in the following figure.

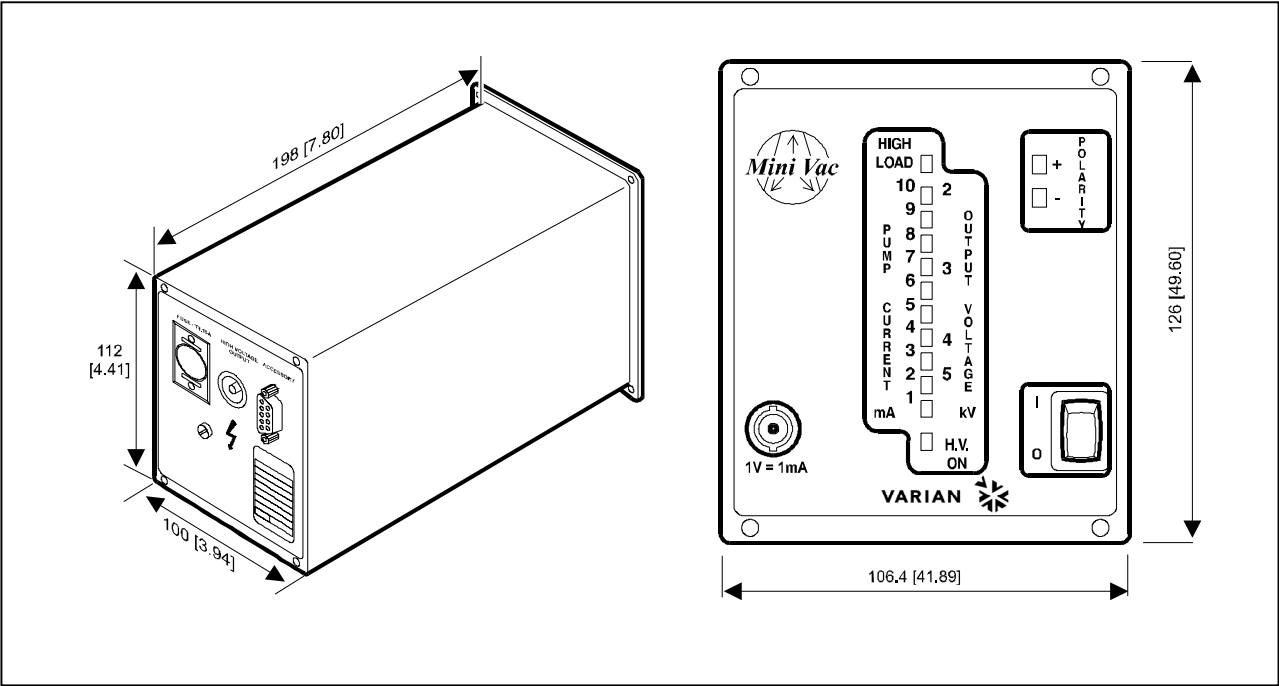

MiniVac Outline Dimensions

**INSTALLATION**

Inspect the controller for any shipping damage.

**WARNING**

The MiniVac controller is shipped with the mating connector for the 24 Vdc supply. This connector must be wired to the 24 Vdc source, according to the connections indicated on the MiniVac rear panel (Pin 1 = positive, Pin 2 = negative).

High voltage developed in the controller can cause severe injury or death. Before servicing the unit, disconnect the input power cable.

**NOTE**

The MiniVac controller can be used as a bench unit or as a rack module, but it must be positioned so that free air can flow through the holes.

**Output Polarity Selection**

The output polarity is selected by the high voltage multiplier card, and is factory set for negative output voltage polarity.

If a change in output polarity is desired, proceed as follows:

- Switch off the power and unplug the power cord from the controller rear panel socket.
- Undo the 9 screws and then remove the cover.
- Disconnect the H.V. white wire (1) from the multiplier board (see the following figure), remove the board (2) and rotate it 180° horizontally; reinstall the board into the socket and reconnect the H.V. white wire.
- Install the cover and screws.
- Connect the power cord then switch on the unit and check on the front panel the output polarity indication.

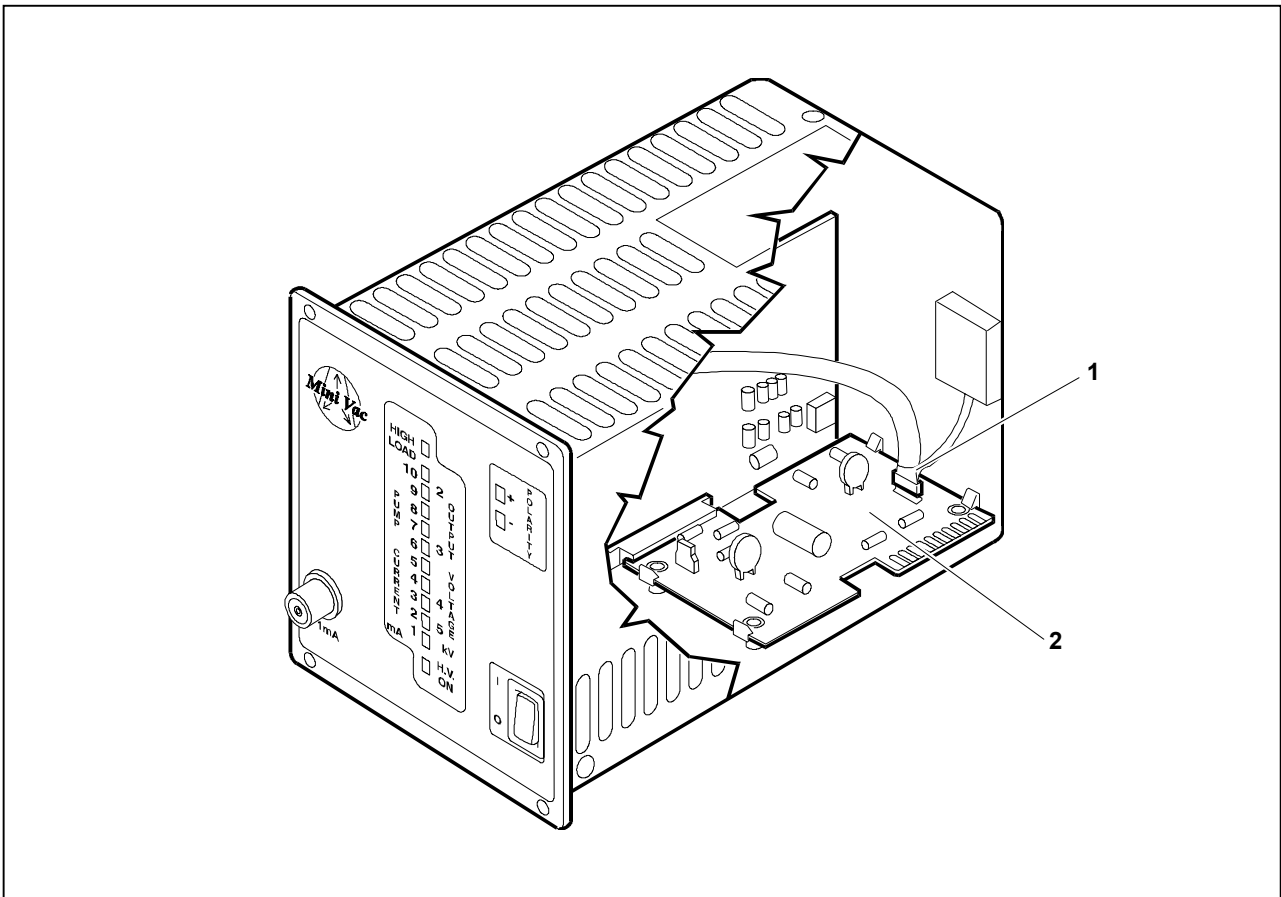

Output Polarity Selection

**Input/Output Interconnections**

All input/output signals are accessible at J001 accessory connector. With the provided P001 mating connector make the connections with AWG 24 (0.2 mm<sup>2</sup>) - or smaller wire - to the pins indicated in the following figure to obtain the desired capability.

**Input signals**

**Pin 3-7** Remote high voltage ON/OFF or high voltage interlock; requires a permanent closed pin contact.

**NOTE**

*Pin 3-7 must be shorted to allow the high voltage output if no remote/interlock contact is connected.*

**Output signals**

**Pin 1-6** Current recorder output 1 (pin 1 signal out, pin 6 ground). The output voltage 0 to + 10 Vdc is proportional to the pump current 0 to 10 mA (e.g. 10 Vdc correspond to 10 mA). The resolution is 10 mV minimum (corresponding to 10 µA).

The front panel REC.OUT connector is a duplicate of this signal on a BNC connector.

**Pin 2-6** Current recorder output 2 (pin 2 signal out, pin 6 ground). The output voltage 0 to + 10 Vdc is proportional to the pump current 0 to 1 mA (e.g. 10 Vdc correspond to 1 mA). The resolution is 10 mV minimum (corresponding to 1 µA).

**Pin 4-8** Voltage recorder output (pin 4 signal out, pin 8 ground). The output voltage 0 to 5 V is proportional to the controller high voltage output 0 to 5 kV (e.g. 1 V corresponds to 1 kV in linear mode).

**Pin 5-9** High voltage indication contact. This pure contact (which carries 1 A at 250 Vac and 0.2 A at 30 Vdc) is open when the high voltage is off and closes when the high voltage in on.

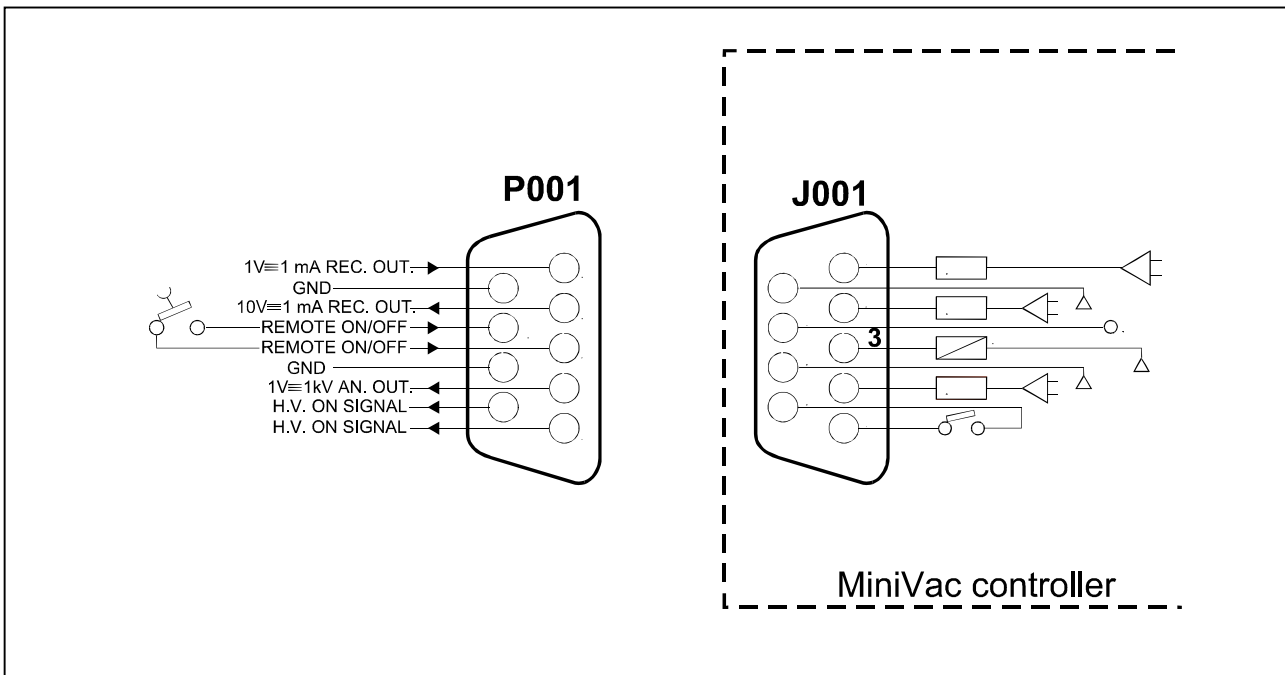

*P001 Mating Connector and J001 Accessory Connector*

**Pump Connection**

The pump is connected to the controller rear panel via the high voltage connector by a coaxial high voltage cable assembly.

**WARNING**

- High voltage can cause severe injury or death. Before installing or removing the connector:*
- Turn the power off.
  - When connecting the cable to 2 l/s pumps, or larger, be sure that the ground spring is in place on the high voltage connection of the pump.
  - Install the pump connector and secure it with screws.
  - Plug the controller connector.

## **OPERATION**

Make all vacuum manifold and electrical connections and refer to the ion pump instruction manual prior to operating the MiniVac controller.

---

### **NOTE**

*The accessory P001 connector should be left in position including the jumper between pin 3 and 7 if no external connection has been made.*

---

*For small ion pumps, up to 8 l/s:*  
with a roughing pump, establish a rough pressure suitable to start the ion pump.

*For medium ion pump (20 l/s to 60 l/s):*  
establish a pressure lower than  $10^{-5}$  mbar/Torr.

*For large ion pumps (120 l/s to 400 l/s):*  
establish a pressure lower than  $2 \times 10^{-6}$  mbar/Torr.

- Plug the controller power cable into a suitable power source.
- Place the ON/OFF switch in the ON position.
- Monitor the Vaclon pump current and the controller high voltage output by watching the LED lit, then read the corresponding current/voltage value (e.g.: if the third LED is increasing its brightness it means that the pump current is between 2 and 3 mA and the high voltage output is between 5 and 4 kV).
- If only the first LED of the bar graph is lit, the current drawn by the pump is less than 1 mA and the voltage output is 5 kV.
- If ten LEDs are lit, the current drawn by the pump is 10 mA and the voltage output is 2 kV.
- For the correct determination of the voltage value, use the voltage vs current diagram shown in the figure "MiniVac Controller Rear Panel Controls".

## **Pressure Determination**

Pressure at the inlet flange of a Vaclon pump is proportional to the current drawn by the pump.

To determine the pressure of the inlet flange of the Vaclon pump, determine the pump current displayed on the front panel or read the recorder output (especially for current lower than 1 mA), and find the corresponding pressure value from the current vs pressure curve of the relevant Vaclon pump.

## **Power Failure**

In the event of a power failure (momentary or long period) the controller is switched off. When power is restored, the controller will automatically restart.

## **Remote Control Mode Operation**

It is possible to remotely switch on and off the high voltage using a permanent contact connected to pins 3 and 7 of J001 accessory connector with the mains power ON/OFF switch to ON.

**MAINTENANCE**

Replacement controllers are available on advance exchange basis through Varian service/sales organization.



**WARNING**

High voltage in the controller can cause severe injury or death. Before servicing, turn power off and remove the power cable.

**Troubleshooting**

- a. No current/voltage LED bar graph lit with mains power ON.
  - Verify mains connections and power fuses
  - Verify on P001 that pins 3-7 are shorted.
- b. Vaclon pump is operating at pressures higher than  $1 \times 10^{-5}$  mbar/Torr and only the first LED is lit.
  - No high voltage output. Replace the unit.
- c. Vaclon pump operating at pressure below  $1 \times 10^{-7}$  mbar/Ton and all LED are lit.
  - Switch power off and disconnect the high voltage cable.
  - Switch power on and verify that only one LED is lit. If this happens the high voltage cable or the pump are shorted.
  - If not, replace the unit.

**Controller Spares and Accessories**

Description	Part number
Mating accessory connector P001	03-648487
24 Vdc mating connector	CANNON XLR-3-11C
Fuse T 3.15A (5x20 mm)	
Rack adapter	969-9191

**Controller to Vaclon Pump Cables**

Description	Part number
H.V. bakeable cable, 4 m long to connect 929-0196 to Star Cell and new Vaclon pump series 919	929-0770
H.V. cable, 3.5 m long to connect 929-0197 to Appendage pumps and conventional Vaclon pump series 911 and 912	924-0741
H.V. bakeable cable, 4 m long to connect 929-0196 to Appendage and conventional Vaclon pump series 911 and 912	929-0780



**VARIAN**

# Request for Return



1. A Return Authorization Number (RA#) **WILL NOT** be issued until this Request for Return is completely filled out, signed and returned to Varian Customer Service.
2. Return shipments shall be made in compliance with local and international **Shipping Regulations** (IATA, DOT, UN).
3. The customer is expected to take the following actions to ensure the **Safety** of workers at Varian: (a) Drain any oils or other liquids, (b) Purge or flush all gasses, (c) Wipe off any excess residues in or on the equipment, (d) Package the equipment to prevent shipping damage, (for Advance Exchanges please use packing material from replacement unit).
4. Make sure the shipping documents clearly show the RA# and then return the package to the Varian location nearest you.

**North and South America**

Varian Vacuum Technologies  
 121 Hartwell Ave  
 Lexington, MA 02421  
 Phone : +1 781 8617200  
 Fax: +1 781 8609252

**Europe and Middle East**

Varian SpA  
 Via Flli Varian 54  
 10040 Leini (TO) – ITALY  
 Phone: +39 011 9979111  
 Fax: +39 011 9979330

**Asia and ROW**

Varian Vacuum Technologies  
 Local Office

**CUSTOMER INFORMATION**

Company name: .....	
Contact person: Name: .....	Tel: .....
Fax: .....	E-Mail: .....
Ship Method: .....	Shipping Collect #: ..... P.O.#: .....
<u>Europe only:</u> VAT reg. Number: .....	<u>USA only:</u> <input type="checkbox"/> Taxable <input type="checkbox"/> Non-taxable
Customer Ship To: .....	Customer Bill To: .....
.....	.....
.....	.....

**PRODUCT IDENTIFICATION**

Product Description	Varian P/N	Varian S/N	Purchase Reference

**TYPE OF RETURN** (check appropriate box)

<input type="checkbox"/> Paid Exchange	<input type="checkbox"/> Paid Repair	<input type="checkbox"/> Warranty Exchange	<input type="checkbox"/> Warranty Repair	<input type="checkbox"/> Loaner Return
<input type="checkbox"/> Credit	<input type="checkbox"/> Shipping Error	<input type="checkbox"/> Evaluation Return	<input type="checkbox"/> Calibration	<input type="checkbox"/> Other .....

**HEALTH and SAFETY CERTIFICATION**

Varian Vacuum Technologies **CAN NOT ACCEPT** any equipment which contains **BIOLOGICAL HAZARDS** or **RADIOACTIVITY**. Call Varian Customer Service to discuss alternatives if this requirement presents a problem.

The equipment listed above (check one):

**HAS NOT** been exposed to any toxic or hazardous materials

OR

**HAS** been exposed to any toxic or hazardous materials. In case of this selection, check boxes for any materials that equipment was exposed to, check all categories that apply:

Toxic    Corrosive    Reactive    Flammable    Explosive    Biological    Radioactive

List all toxic or hazardous materials. Include product name, chemical name and chemical symbol or formula.

.....

Print Name: ..... Customer Authorized Signature: .....

Print Title: ..... Date: ...../...../.....

**NOTE:** If a product is received at Varian which is contaminated with a toxic or hazardous material that was not disclosed, **the customer will be held responsible** for all costs incurred to ensure the safe handling of the product, and **is liable** for any harm or injury to Varian employees as well as to any third party occurring as a result of exposure to toxic or hazardous materials present in the product.

Do not write below this line

Notification (RA)#: ..... Customer ID#: ..... Equipment #: .....



## Request for Return



### FAILURE REPORT

#### TURBO PUMPS and TURBOCONTROLLERS

<input type="checkbox"/> Does not start <input type="checkbox"/> Does not spin freely <input type="checkbox"/> Does not reach full speed <input type="checkbox"/> Mechanical Contact <input type="checkbox"/> Cooling defective	<input type="checkbox"/> Noise <input type="checkbox"/> Vibrations <input type="checkbox"/> Leak <input type="checkbox"/> Overtemperature	<b>POSITION</b> <input type="checkbox"/> Vertical <input type="checkbox"/> Horizontal <input type="checkbox"/> Upside-down <input type="checkbox"/> Other: .....	<b>PARAMETERS</b> Power:                      Rotational Speed: Current:                     Inlet Pressure: Temp 1:                      Foreline Pressure: Temp 2:                      Purge flow: <hr/> OPERATION TIME:
<b>TURBOCONTROLLER ERROR MESSAGE:</b>			

#### ION PUMPS/CONTROLLERS

<input type="checkbox"/> Bad feedthrough <input type="checkbox"/> Vacuum leak <input type="checkbox"/> Error code on display	<input type="checkbox"/> Poor vacuum <input type="checkbox"/> High voltage problem <input type="checkbox"/> Other
Customer application:	

#### VALVES/COMPONENTS

<input type="checkbox"/> Main seal leak <input type="checkbox"/> Solenoid failure <input type="checkbox"/> Damaged sealing area	<input type="checkbox"/> Bellows leak <input type="checkbox"/> Damaged flange <input type="checkbox"/> Other
Customer application:	

#### LEAK DETECTORS

<input type="checkbox"/> Cannot calibrate <input type="checkbox"/> Vacuum system unstable <input type="checkbox"/> Failed to start	<input type="checkbox"/> No zero/high background <input type="checkbox"/> Cannot reach test mode <input type="checkbox"/> Other
Customer application:	

#### INSTRUMENTS

<input type="checkbox"/> Gauge tube not working <input type="checkbox"/> Communication failure <input type="checkbox"/> Error code on display	<input type="checkbox"/> Display problem <input type="checkbox"/> Degas not working <input type="checkbox"/> Other
Customer application:	

#### PRIMARY PUMPS

<input type="checkbox"/> Pump doesn't start <input type="checkbox"/> Doesn't reach vacuum <input type="checkbox"/> Pump seized	<input type="checkbox"/> Noisy pump (describe) <input type="checkbox"/> Over temperature <input type="checkbox"/> Other
Customer application:	

#### DIFFUSION PUMPS

<input type="checkbox"/> Heater failure <input type="checkbox"/> Doesn't reach vacuum <input type="checkbox"/> Vacuum leak	<input type="checkbox"/> Electrical problem <input type="checkbox"/> Cooling coil damage <input type="checkbox"/> Other
Customer application:	

### FAILURE DESCRIPTION

(Please describe in detail the nature of the malfunction to assist us in performing failure analysis):

**NOTA:** Su richiesta questo documento è disponibile anche in Tedesco, Italiano e Francese.

**REMARQUE :** Sur demande ce document est également disponible en allemand, italien et français.

**HINWEIS:** Auf Anfrage ist diese Unterlage auch auf Deutsch, Italienisch und Französisch erhältlich.

## Sales and Service Offices

### United States and Canada Varian, Inc.

121 Hartwell Avenue  
Lexington, MA 02421  
USA  
Tel.: +1 781 861 7200  
Fax: +1 781 860 5437  
Toll-Free: +1 800 882 7426

### Benelux Varian Vacuum Technologies

Herculesweg 8  
4338 PL Middelburg  
The Netherlands  
Tel.: +31 118 671570  
Fax: +31 118 671569

### China Varian Technologies China, Ltd.

Rm 1648 Central Tower South Wing  
Beijing Junefield Plaza  
No. 10 XuanWuMenWai Street  
Beijing 100052, P.R. China  
Tel.: +86 (10) 6310 8550  
Fax: +86 (10) 6310 0141  
Toll-Free: 800 820 6556

### France Varian s.a.

7 Avenue des Tropiques  
Z.A. de Courtaboeuf - B.P. 12  
Les Ulis cedex (Orsay) 91941 France  
Tel: +33 1 69 86 38 84  
Fax: +33 1 69 86 29 88

### Germany and Austria Varian Deutschland GmbH

Alsfelder Strasse 6  
Postfach 11 14 35  
64289 Darmstadt  
Germany  
Tel: +49 6151 703 353  
Fax: +49 6151 703 302

### India Varian India PVT Ltd.

205-A, "A" wing of Galleria,  
2nd floor, Hiranandani Gardens,  
Powai, Mumbai-400 076, India  
Tel.: +91 22-2570 8595 / 8597  
Fax: +91 22- 2570 8599

### Italy Varian S.p.A.

Via F.lli Varian, 54  
10040 Leini (Torino)  
Italy  
Tel: +39 011 997 9111  
Fax: +39 011 997 9350

### Japan Varian Technologies Japan, Ltd.

Sumitomo Shibaura Building, 8th Floor  
4-16-36 Shibaura Minato-ku  
Tokyo 108, Japan  
Tel.: +81 3 5232 1253  
Fax: +81 3 5232 1710  
Toll-Free: 0120 655 040

### Korea Varian Technologies Korea, Ltd.

Shinsa 2nd Bldg. 2F, 966-5 Daechi-dong  
Kangnam-gu, Seoul  
Korea 135-280  
Tel.: +82 2 3452 2452  
Fax: +82 2 3452 2451  
Toll-Free: 080 222 2452

### Mexico Varian, S. de R.L. de C.V.

Concepcion Beistegui No 109  
Col Del Valle  
C.P. 03100  
Mexico, D.F.  
Tel.: +52 5 523 9465  
Fax: +52 5 523 9472

### South East Asia Varian Vacuum Technologies

South East Asia (SEA)  
Tel.: +601 2213 1253  
Fax: +603 6733 8121

### Singapore Varian Vacuum Technologies Singapore

Unit 10-04 Helios  
Biopolis @ one-north  
11 Biopolis Way, 138667 Singapore  
Tel.: +65 92364988  
Fax: +65 64789603

### Taiwan Varian Technologies Asia Ltd.

14F-6, No.77, Hsin Tai Wu Rd., Sec. 1  
Hsi chih, Taipei Hsien  
Taiwan, R.O.C.  
Tel.: +886 2 2698 9555  
Fax: +886 2 2698 9678  
Toll Free: 0800 051 342

### UK and Ireland Varian Ltd.

6 Mead Road  
Oxford Industrial Park - Yarnton  
Oxford OX5 1QU - England  
Tel.: +44 (0) 1865 291570  
Fax: +44 (0) 1865 291571

### Other Countries Varian S.p.A. Vacuum Technologies

Via F.lli Varian, 54  
10040 Leini (Torino)  
Italy  
Tel: +39 011 997 9111  
Fax: +39 011 997 9350

### Customer Support & Service:

**North America**  
Toll-Free: 1 800 882 7426  
vtl.variancare@varianinc.com

**Europe**  
Toll-Free: 00 800 234 234 00  
vtt.variancare@varianinc.com

**China**  
Toll-Free: 800 820 8266  
vtc.technical.support@varianinc.com

**Japan**  
Toll-Free: 0120 655 040  
vtj.technical.support@varianinc.com

**Korea**  
Toll-Free: 080 222 2452  
vtk.technical.support@varianinc.com

**Taiwan**  
Toll-Free: 0 800 051 342  
vtw.technical.support@varianinc.com

**Worldwide Web Site, Catalog  
and Order On-line:**  
www.varianinc.com

Representative in most countries

