

Agilent 1290 Infinity Pump Service Kit

Contents

“Overview of 1290 Infinity Pump Service Kit” on page 2

“Overview of Maintenance parts” on page 2

“Disassembling the Pump Head” on page 3

“Disassembling the Primary Pump Head” on page 5

“Disassembling the Secondary Pump Head” on page 8

“Assembling the Pump Head” on page 12

Pump Alignment Tool (lower part)

Pump Alignment Tool Handle

Pump Alignment Tool (upper part)

Bit Kit

Plunger Assy

**Torque Wrench
2-25Nm**

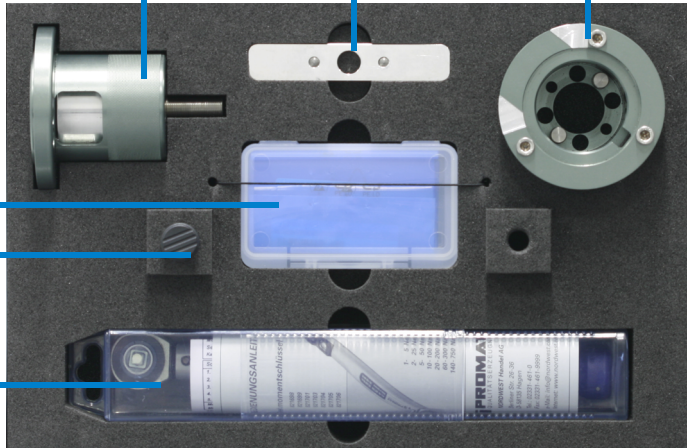

Agilent Technologies

Overview of 1290 Infinity Pump Service Kit

Table 1 1290 Infinity Pump Service Kit

Description	Part Number
Pump Head Alignment Tool	5023-0279
Torque Wrench 2-25Nm	G4220-20012
Bit Kit	5023-0282
4 mm hex bit, 89mm length	
2.5 mm hex bit	
adapter 1/4 inch square to hex	
1290 Infinity Pump Service Kit Note	G4220-90120

Overview of Maintenance parts

Table 2 Maintenance parts

Description	Part Number
Pump Seals PE	0905-1719
Piston 1290 Binary Pump	5067-4603
Gasket (Seal Wash)	G4220-20015
Backup Seal PE (Seal Wash)	0905-1718
PTFE frits, 5 er pack	01018-22707
Gold seal	5001-3707
Cap	5042-1346

Disassembling the Pump Head

When	If parts inside the pump head need to be replaced
Tools required	14mm wrench 4mm Hex key 2.5mm hex bit
Parts required	See Table 2 , "Maintenance parts," on page 2

NOTE

This procedure describes replacements for the pump heads of channel A. Replacement for channel B can be done accordingly. The primary pump head does not have a heat exchanger. Seal wash parts are optional.

1 Do NOT switch off the pump. Use your service user interface, for example Lab Advisor for bringing the pump to its maintenance position. In Lab Advisor go to **Tools > Remove/Install Pump Head** and follow instructions given on the screen.

2 Close the shut-off valve of the respective pump channel.

3 Remove the flow connection between the degassing unit and the primary pump head inlet. Remove the capillary connection at the top of the secondary pump head to the pump valve.

DO NOT REMOVE the capillary connection between the pump heads marked by the red X.

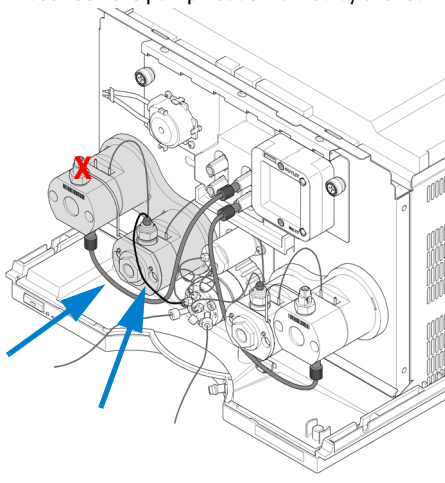

4 Open the 4 screws holding the pump heads.

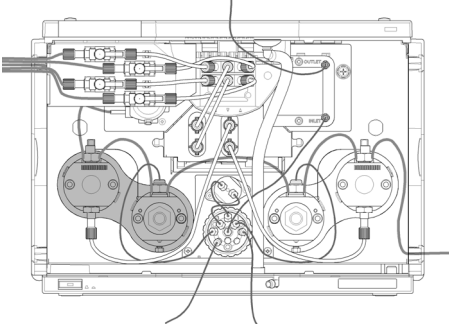

NOTE

Open all screws step by step, not screw by screw.

5 Open the hex screw at the top of the primary pump head, which fixes the connection capillary of the heat exchanger. Then lift up the capillary and remove it from the primary pump head..

Heat exchanger with connection capillary

Link plate

Primary pump head

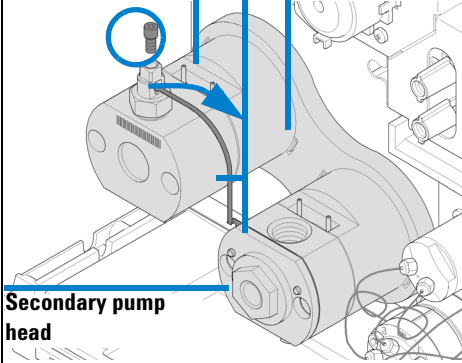

6 Remove both pump heads from the link plate by pushing the clips at the rear of the plate..

Link plate

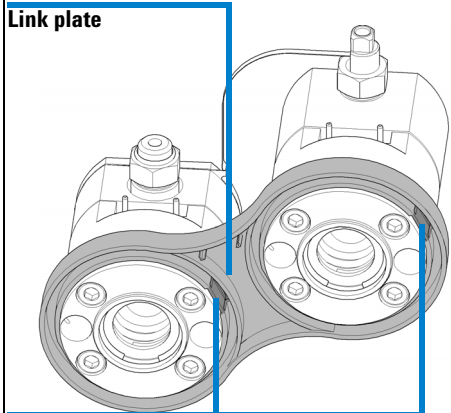

Clips

Disassembling the Primary Pump Head

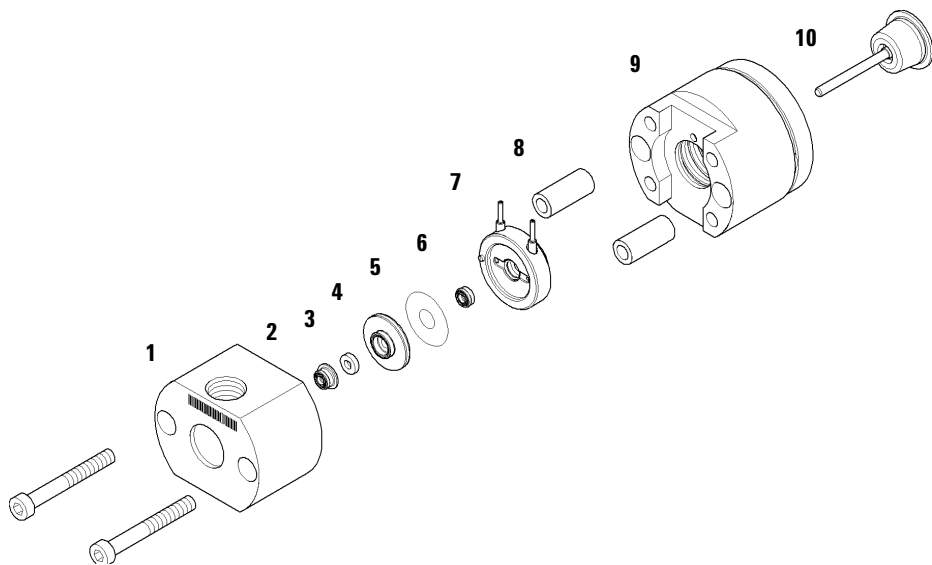

Figure 1 Pump Head (with seal wash option)

1	Pump head chamber housing
2	Pump seal
3	Backup ring for seal holder
4	Seal holder
5	Film washer (seal wash)
6	Backup seal PE for seal wash
7	Support ring (seal wash)
8	Pump head ferrule
9	Piston housing
10	Piston

CAUTION

Damage of pump piston

7 The pump piston has an excellent stability and chemical resistance inside the pump head, but it is sensitive to shearing forces from the side.

- Do not try to remove the pump piston from the rear.
- Do not use the piston for removing pump seals.

1 Remove the outlet valve at the top of the pump head and the inlet valve at the bottom of the pump head..

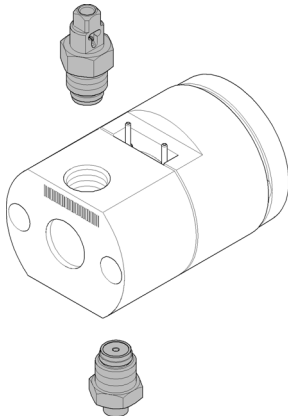

2 For disassembling the pump head, open the 4 hex screws and remove screws at the rear of the pump head.

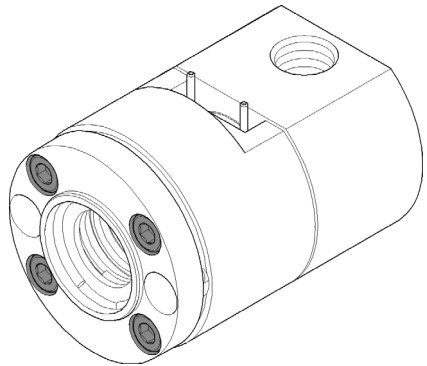

3 Remove the front part of the pump head including pump chamber housing with pump seal and support ring. If the seal wash option is installed, also remove the seal holder with backup seal and gasket.

- Make sure, that the backup ring inside the seal holder does not drop out. Do not remove it from the holder..

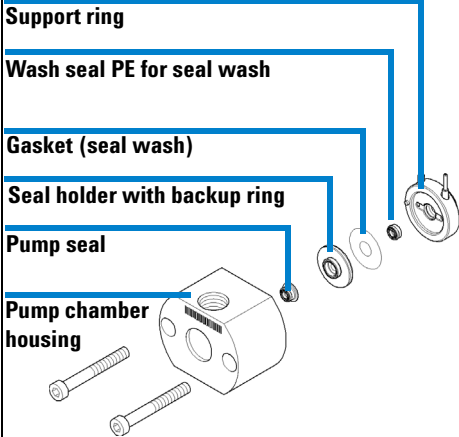

4 Remove the piston from the piston housing by pushing it to the rear, then pull it out from the rear..

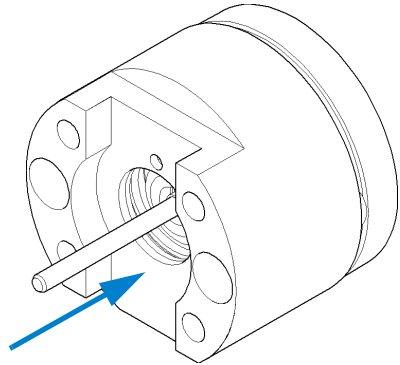

5 Use the insert tool of the pump head alignment tool for removing the pump seal from the pump chamber housing.

- Do not use the pump piston for that purpose!

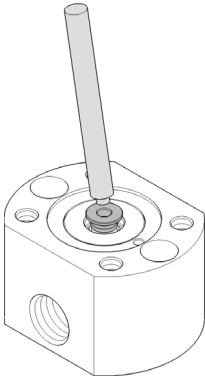

6 If the wash seal shall be replaced by a new one, use a screw driver for removing it.

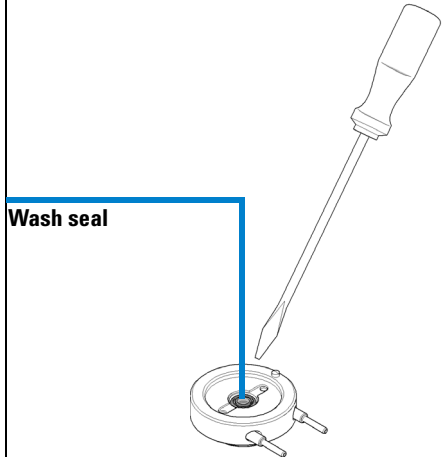

Disassembling the Secondary Pump Head

CAUTION

Loss of small spacer fitting

Inside the secondary pump head is a small spacer fitting, which can be dropped easily when removing the heat exchanger.

→ Be careful when removing the heat exchanger.

CAUTION

Damage of pump piston

The pump piston has an excellent stability and chemical resistance inside the pump head, but it is sensitive to shearing forces from the side.

→ Do not try to remove the pump piston from the rear.

→ Do not use the piston for removing pump seals.

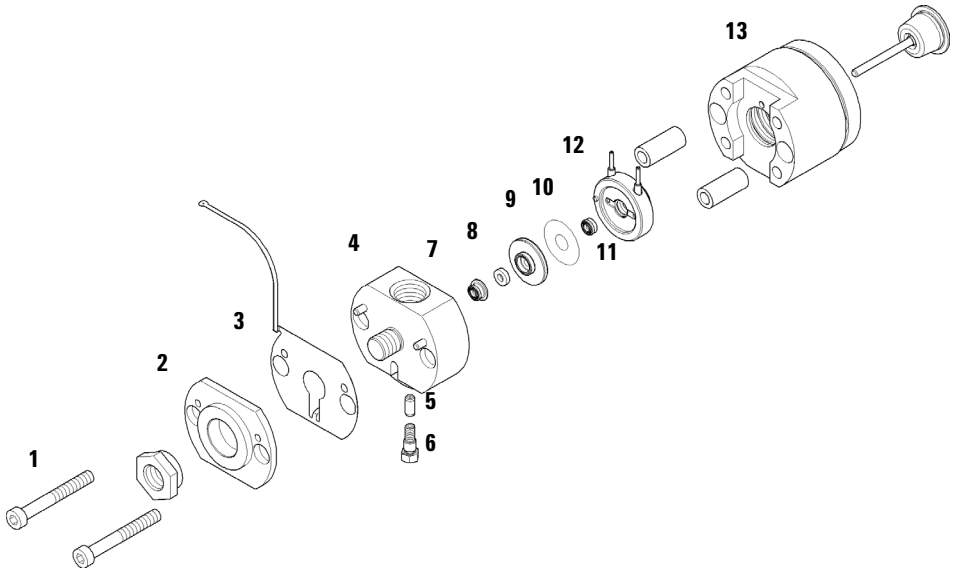

1	Pump head screw
2	Pump head front plate
3	Heat exchanger (primary pump head only)
4	Pump chamber housing
5	Spacer fitting
6	Pump head hex screw
7	Pump seal
8	Backup ring for seal holder
9	Seal holder
10	Gasket (seal wash)
11	Wash Seal PE (seal wash)
12	Support ring (seal wash)
13	Piston housing

1 Remove the filter assembly at the top of the pump head. See *Agilent 1290 Infinity Binary Pump User Manual* for replacing the filter frit..

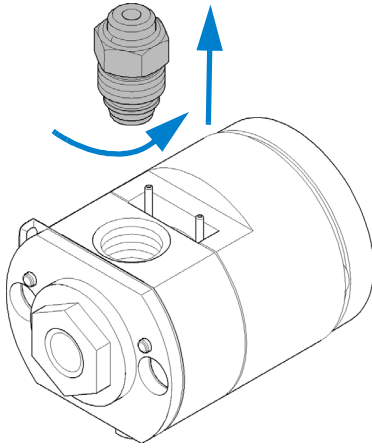

2 For disassembling the pump head, open the 4 hex screws at the rear of the pump head..

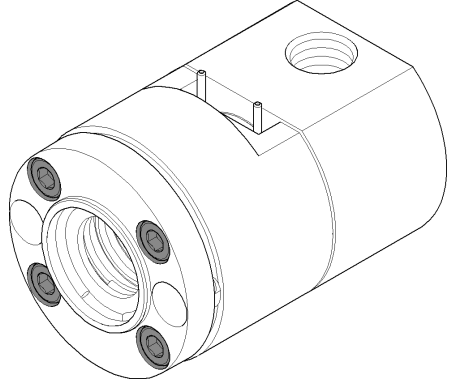

3 Remove the front part of the pump head including pump chamber housing with pump seal and support ring. If the seal wash option is installed, also remove the seal holder with backup seal and gasket.

- Make sure, that the backup ring inside the seal holder does not drop out. Do not remove it from the holder..

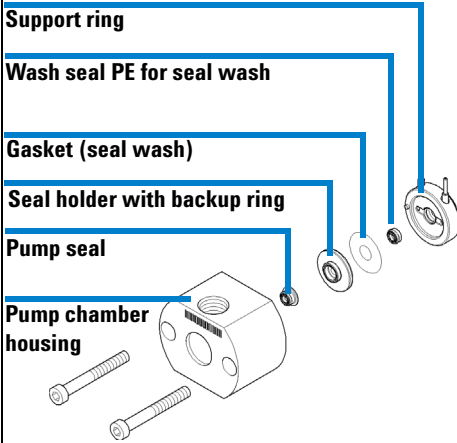

4 Remove the piston from the piston housing by pushing it to the rear, then pull it out from the rear..

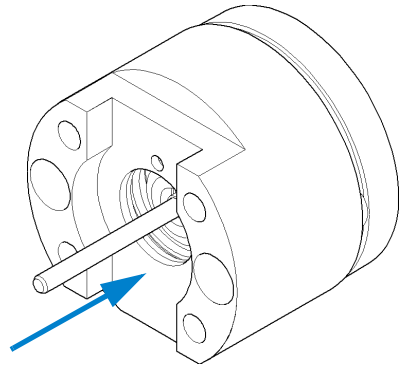

5 Use the insert tool of the pump head alignment tool for removing the pump seal from the pump chamber housing.

- Do not use the pump piston for that purpose!

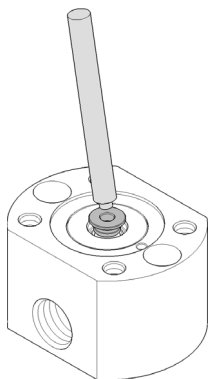

6 If the wash seal shall be replaced by a new one, use a screw driver for removing it.

Wash seal

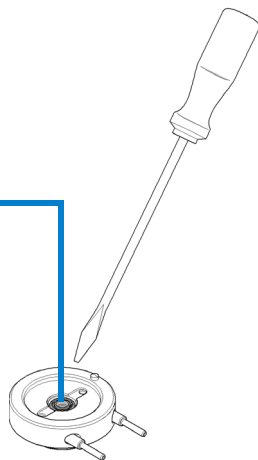

Assembling the Pump Head

When Befor installing the pump.

Tools required	5023-0279	Pump Head Alignment Tool
	G4220-20012	Torque wrench 2-25 Nm
	01018-23702	Insert Tool
	G4220-20013	4 mm Hex bit
	G4220-20015	Adapter ¼ square to hex

CAUTION

Limited life time of the pump head

Inserting the backup seal wrongly may limit the life time of the pump.

→ Please note the correct orientation of the backup seal.

CAUTION

Damage of the pump piston

The pump piston is sensitive to shearing forces from the side.

→ Use the Plunger assy of the pump head alignment tool for the alignment procedure described below.

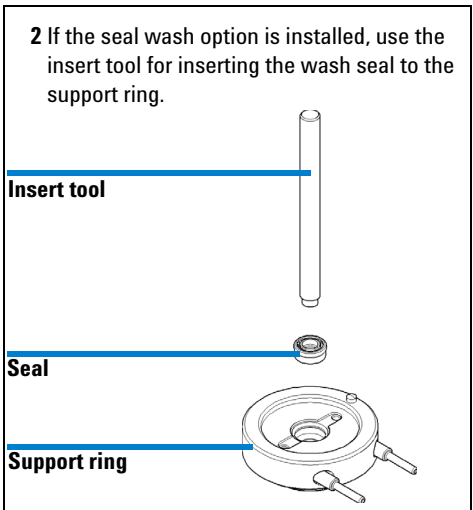
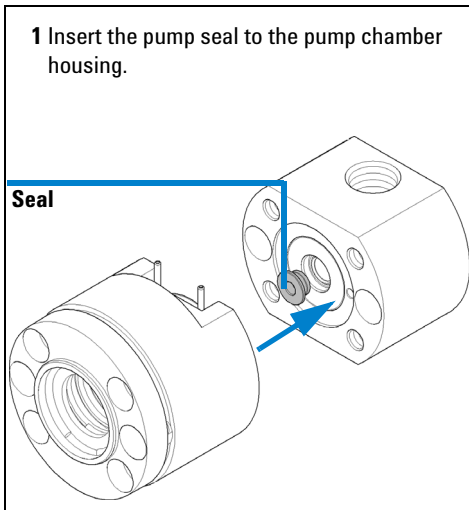

3 If the backup seal has been removed from the seal holder, insert it in the correct orientation as shown below. Ensure that the cut end faces the seal holder..

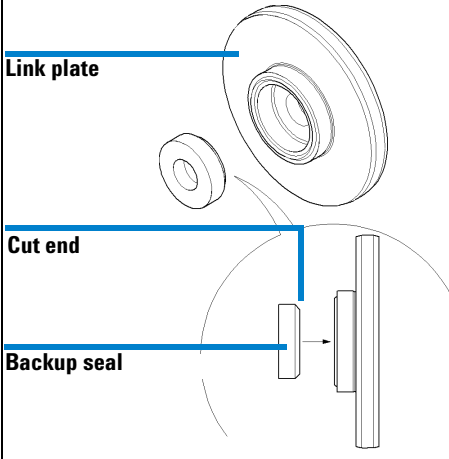

4 If the seal wash option is installed, put the gasket into the support ring and insert the seal holder..

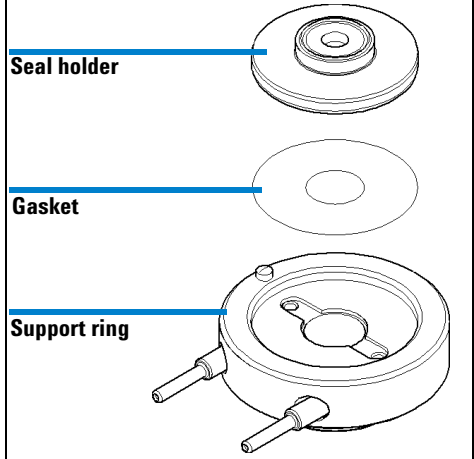

5 Insert the support ring and pump head ferrules into the piston housing. Assemble the pump head by putting the pump chamber housing on top of the support ring.

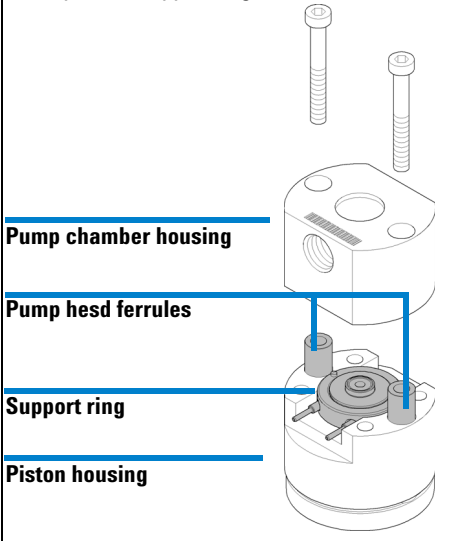

6 Loosely close the 4 screws at the rear of the pump head. The screws will be fixed tightly later. Then insert the plunger assy.

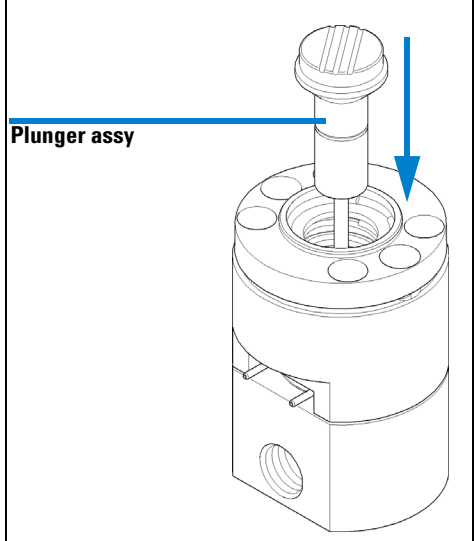

7 Insert the primary or secondary pump head to the pump head alignment tool. There are openings for the seal wash support ring and heat exchanger of the secondary pump head.

Pump head alignment tool (rear)

Pump head (secondary)

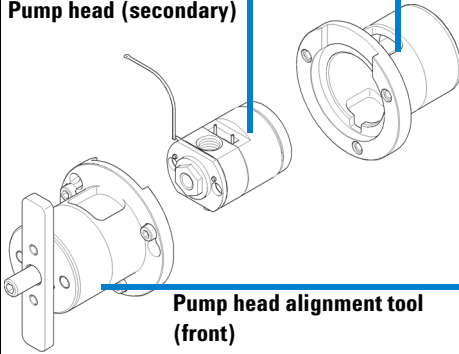

8 Close the tool by closing the 3 screws at the connection ring.

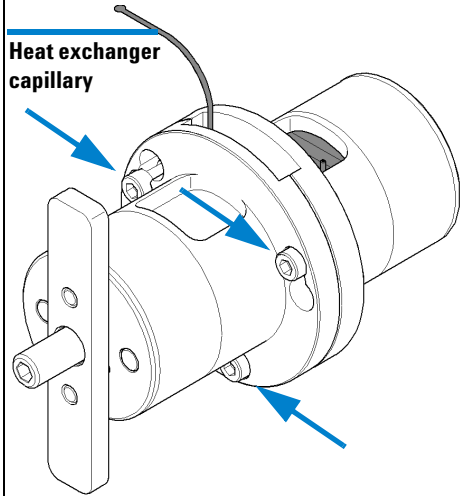

9 Using a torque key, set 5 Nm and close the screw at the front of the pump head alignment tool. Then close the 4 screws at the rear of the pump head with 5 Nm.

front

rear

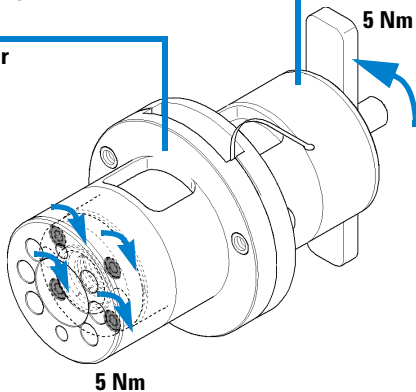

NOTE

This procedure will align pump head parts to their correct positions and close the pump head tightly.

10 Open the 3 screws which have closed the pump head alignment tool and take out the aligned pump head.

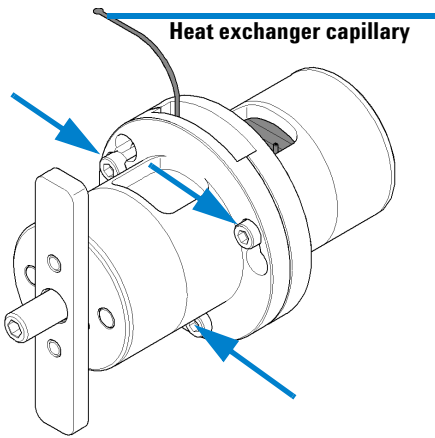

11 For the primary pump head, install the inlet valve and outlet valve.

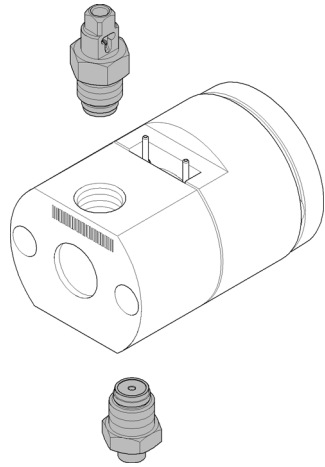

12 For the secondary pump head, assemble and install the outlet valve as shown.

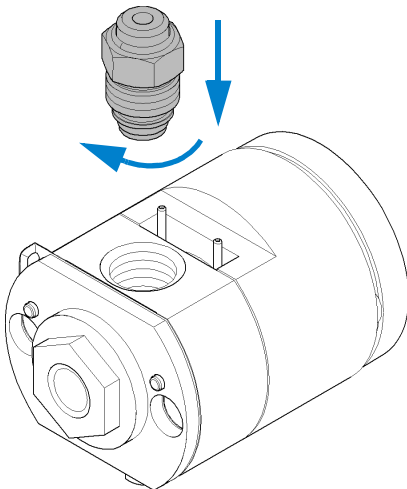

13 Remove plunger assy..

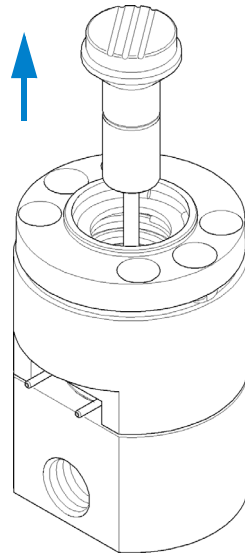

14 Insert pump piston

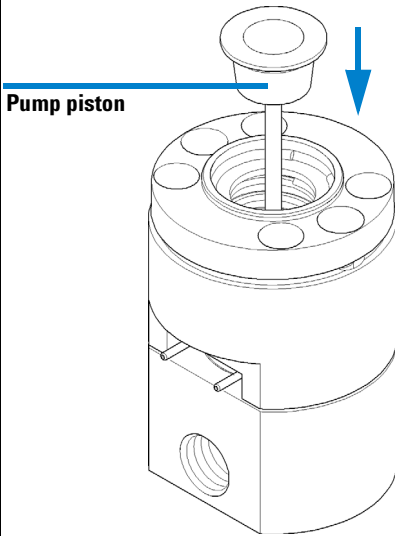

15 Insert both pump heads in the link plate and make sure that the clips snap in that fix the pump heads.

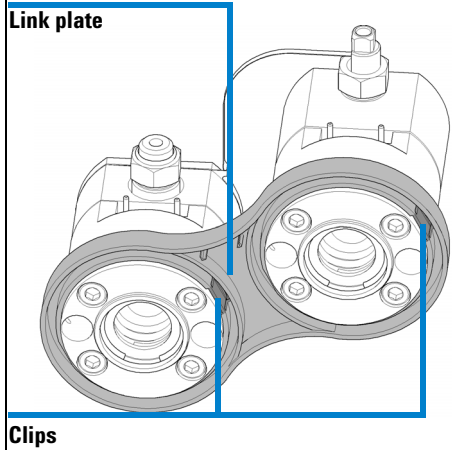

16 Insert the heat exchanger capillary into the outlet of the primary pump head. Using a torque key, set 3 Nm and close the hex screw at the top of the outlet.

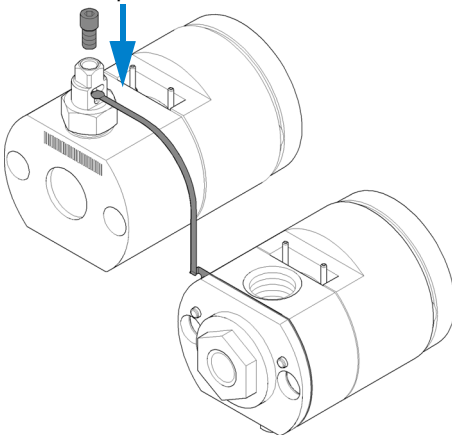

17 Install the pump head assembly and install flow connections as described in Replacing the pump heads, described in the user Manual.

© Agilent Technologies 2010
Part Number: [G4220-90120](#)



Edition: 04/10

Printed in Germany
Agilent Technologies
Hewlett-Packard-Strasse 8
76337 Waldbronn