

Wellplate Autosampler Purge Kit

- Features [2](#)
- General Information [3](#)
- Installing the Wellplate Autosampler Purge Kit [4](#)
- How to Use the Wellplate Autosampler Purge Kit [7](#)
- General Operating Considerations [7](#)
- ChemStation Operation [8](#)
- High Throughput Settings [8](#)
- Cleaning Wellplate Sampler Settings [9](#)
- Control Module Operation [10](#)
- G1373A Wellplate Autosampler Purge Kit Parts [12](#)

The installation and use of the new Wellplate Autosampler Purge Kit are described in detail in this note.



Features

The new Wellplate Autosampler Purge Kit offers the following features:

- Fits for Agilent 1100 Series Wellplate Autosampler (G1367A and G1368A (thermostatted)).
- Minimizes carry over for viscous samples, minimum injection volumes, maximum sensitivity and if the Wellplate Autosampler is purged only for very short times (fast, high throughput injections, bypass mode for Automatic Delay Volume Reduction (ADVR) or Overlapped Injection (OI)).
- Convenient Software control fully operated and controlled through the ChemStation or G1323B Control Module via the Wellplate Autosampler Settings (Requires Agilent ChemStation B.01.03 or higher and Firmware A.06.01 and higher on ALL Agilent 1100 Series modules that are part of the system and Firmware B.04.01 for the Control Module).

General Information

When to use the Wellplate Autosampler Purge Kit

When working with detectors at maximum sensitivity it may become more and more important to remove even minimal traces of previously injected sample mixtures, that can potentially be retained in the needle, seat or in the injection valve of the used Autosampler. The Agilent 1100 Series system itself offers superior design and techniques to minimize the potential sources and impacts of carry over. However for some critical types of sample (if the sample is e.g. extremely viscous) or if the system is used at maximum sensitivity with minimum injection volumes an even further decrease of carry over might be desirable. If an Autosampler is switched to the “Bypass Mode” (for Overlapped Injections (OI) or to minimize the delay volume (ADVR)) the exposure of the Autosampler’s internal flow path parts to the solvent flow coming from the pump may become too short and special treatment might be required to reduce carry over. The Wellplate Autosampler Purge kit was developed for this purpose.

Installing the Wellplate Autosampler Purge Kit

Table 1 Requirements and preparation

| | Description | Part Number |
|--|---|-------------|
| • Tools required | 9/64" hexagonal key (shipped with this kit) | 8710-2394 |
| | 1/4 inch wrench (shipped with every 1100 Series instrument) | 8710- 0510 |
| | paper clip | N/A |
| • Parts required | Wellplate Autosampler Purge Kit (for a detailed ship list please refer to "Parts and Materials" at the end of this note) | G1373A |
| • Preparations for this procedure | <p>Switch off the Online Vacuum Degasser (if present), Pump and Wellplate Autosampler at the main power switch.</p> <p>Remove the front covers (from Online Vacuum Degasser (if present) and Pump).</p> <p>Remove all cables to and from Online Degasser (if present), Pump and Wellplate ALS.</p> <p>Remove all capillaries and tubing to and from pump and Wellplate ALS.</p> | |

- 1 Remove all 1100 Series modules that are placed on top of the Wellplate Autosampler.
- 2 Remove the top plastic cover from the Wellplate Autosampler as described in the *Wellplate Autosampler Reference Manual*.
- 3 Assemble the new top plastic cover which includes the rail for the purge valve on the right side (seen from the front) panel, shipped with this kit. For the assembly of the kit follow the instructions given in the *Wellplate Autosampler Reference Manual*.

NOTE

Don't forget to install the new bolt carrier before mounting the 2 side covers! The bolt carrier is installed in the front of the top cover for mounting the front door. Mind the orientation of the side panels. Be careful not to mix up front and rear, left and right sides. Remove the front door from the old top plastic cover with the help of a flat blade screwdriver to install it into the new top plastic cover. Remove the Agilent name plate from the old top plastic cover with the help of a paper clip, by pushing the plate out from the rear to the front with one stretched end of the paper clip and install it into the new top plastic cover.

- 4 Install the new top plastic cover.
- 5 Place all instrumentation that was previously installed on top of the Wellplate Autosampler on top of the Wellplate Autosampler again.
- 6 Slide the new G1156A 6-Position-7-Port Valve onto the new rail at the right side of the Wellplate Autosampler, in a way, that its ports are facing the user.

- 7 Connect all CAN cables to all modules, again. Include the new G1156A 6-Position-7-Port Valve when connecting the modules with the CAN cables.
- 8 Connect the power cords to all modules, again. Use the DC-CAN cable to connect line power from the Wellplate Autosampler's 24 V DC outlet (at the rear right of the instrument) to the rear of the new G1156A 6-Position-7-Port Valve.
- 9 Using the instructions, given in the *Wellplate Autosampler Reference Manual*, replace the std. rotor seal of the Wellplate Autosampler's injection valve by the new 3-Grove seal (PN 0101-1409), delivered with this kit.

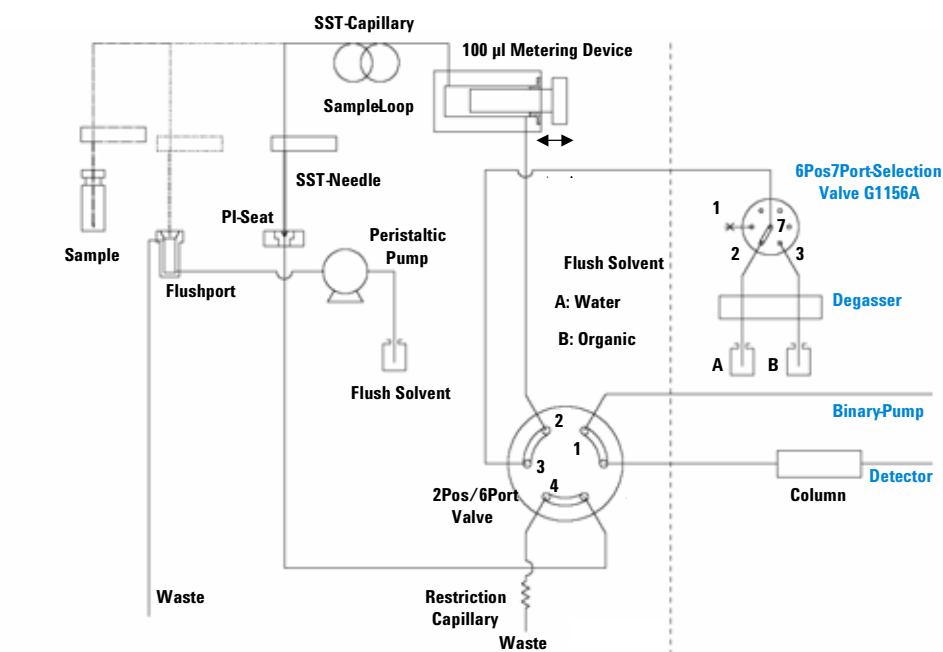

Figure 1 Scheme of the modified flowpath of the Agilent 1100 Series Wellplate Autosampler including the Purge Kit

Connect all capillaries and tubing to the modules, as shown in [Figure 1](#) and as described below:

- 10 Connect the solvent capillary from the pump to port 1 of the Wellplate Autosampler's injection valve.
- 11 Connect the solvent capillary to the column to port 6 of the Wellplate Autosampler's injection valve.
- 12 The capillary from port 2 of the Wellplate Autosampler's injection valve to the metering head remains connected as it is.
- 13 Remove the plug from port 3 and replace it by the flexible flush solvent capillary (PN 5065-9980).
- 14 Connect the other end of the flexible flush solvent capillary to the center port (7) of the new G1156A 6-Position-7-Port Valve.
- 15 Replace the original waste tubing at port 4 of the Wellplate Autosampler's injection valve by the new restriction capillary (PN G1373-87300), delivered with this kit.

Wellplate Autosampler Purge Kit
Installing the Wellplate Autosampler Purge Kit

- 16** The capillary from port 5 of the Wellplate Autosampler’s injection valve to the needle seat remains connected as it is.

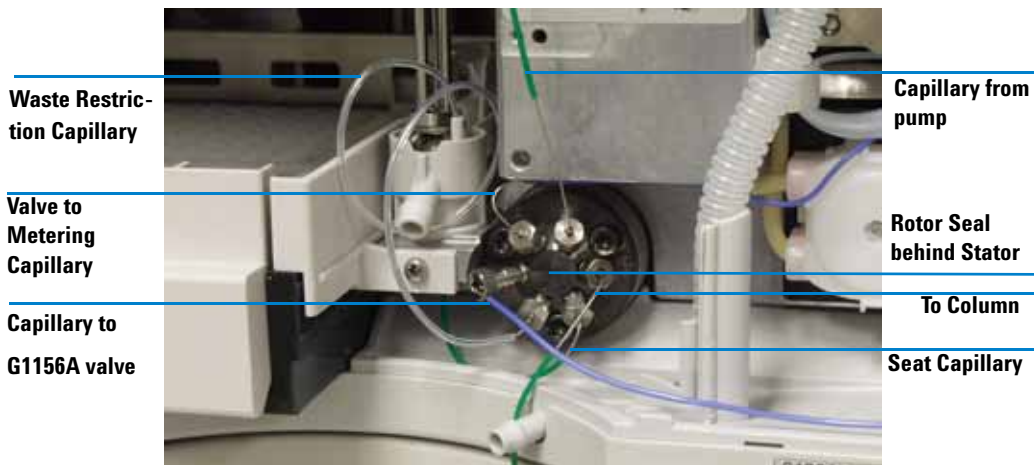

Figure 2 Wellplate Autosampler Injection Valve Connections

- 17** Install the blanking nut (PN 01080-83202) to port 1 of the new G1156A 6-Position-7-Port Valve.
- 18** Connect the flush solvents A and B from their solvent reservoirs using the bottle head assemblies (PN G1311-60003) to the degasser channel inlets that are still unused (if present), and from there
- 19** Connect the 2 tubings of the 100 cm tubing set (G1373-67300) to the degasser outlet ports of the 2 flush solvent channels.

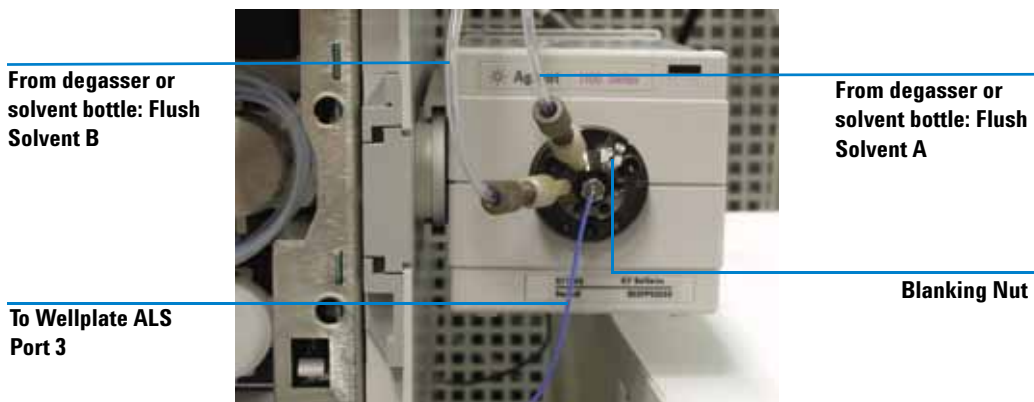

Figure 3 G1156A 6-Position/7-Ports Purge Valve Connections

- 20** Prime the two flush solvent tubings from the degasser, by connecting the priming syringe adapter and the priming syringe to their open ends and pulling at the syringe until the tubings are completely filled with solvent.
- 21** Remove the priming syringe and adapter from the tubings and connect them to ports 2 and 3 of the new G1156A 6-Position-7-Port Valve with the help of the 2 PEEK adapters (PN 0100-1847).
- 22** Close all front doors and powercycle all modules.

How to Use the Wellplate Autosampler Purge Kit

The Wellplate Autosampler Purge Kit is operated and controlled through the ChemStation or G1323B Control Module via the Wellplate Autosampler Settings (Requires Agilent ChemStation B.01.03 or higher and Firmware A.06.01 and higher on ALL Agilent 1100 Series modules that are part of the system and Firmware B.04.01 for the Control Module).

General Operating Considerations

The functionality of the Purge Kit is based on the addition of the 6-Position-7-Port Valve, which is connected to the Wellplate Autosampler and 2 rinsing solvents as shown in figure 1. All parameters for the Purge Kit are set in the ChemStation or in the Control Module. After the injection has been completed the injection valve is switched into the bypass mode. By doing so the delay volume of the Wellplate Autosampler is removed from the flow path and bypassed. After the injection valve inside the Wellplate Autosampler is switched the G1156A 6-Position-7-Port Purge Valve is switched to the position with the strong solvent and the metering device starts to clean the injection system with the strong dissolving liquid. After having cleaned the system, the purge valve is switched to the weak solvent and the injector capillaries, the needle and the seat are rinsed with the weak solvent to ensure, that the separation of the following run is not influenced by remaining strong solvent. The times and volumes at which the system is cleaned with the strong and with the weak solvent can be set independently in the user interface.

Solvent Considerations

The STRONG SOLVENT (highly concentrated or pure organic in reversed phase chromatography, pure water or aqueous solutions for normal phase) should be selected with the same solvent strength as the maximum strength of the solvent during the analysis (for gradient analyses) or even higher. It must at least be strong enough to reliably flush out any remainders of sample from the Autosampler's flow path during the purge cycle.

The WEAK SOLVENT (pure water or a mixture of a low concentration of organic with water for reversed phase analyses and highly concentrated or pure organic solvents for normal phase analyses) should be selected with a solvent strength or composition that is similar or identical to the initial mobile phase composition at the beginning of the run prior to the injection in order to avoid any negative impact of a too strong solvent at the beginning of the analysis.

NOTE

Please refer also to the Application Note "Optimization of Agilent 1100 Series Well Plate Sampler for lowest Carry Over using optional Purge Kit" (Pub.-No. 5989-3357EN) for more information about optimizing the use of the operating parameters using the Purge kit.

ChemStation Operation

Activating the valve is done under
<Settings --> More Injector --> Configuration --> Rinse Valve Enable
(not shown --> in the Screenshots, given below). This must be performed first, before receiving access to all of the Purge-Settings.

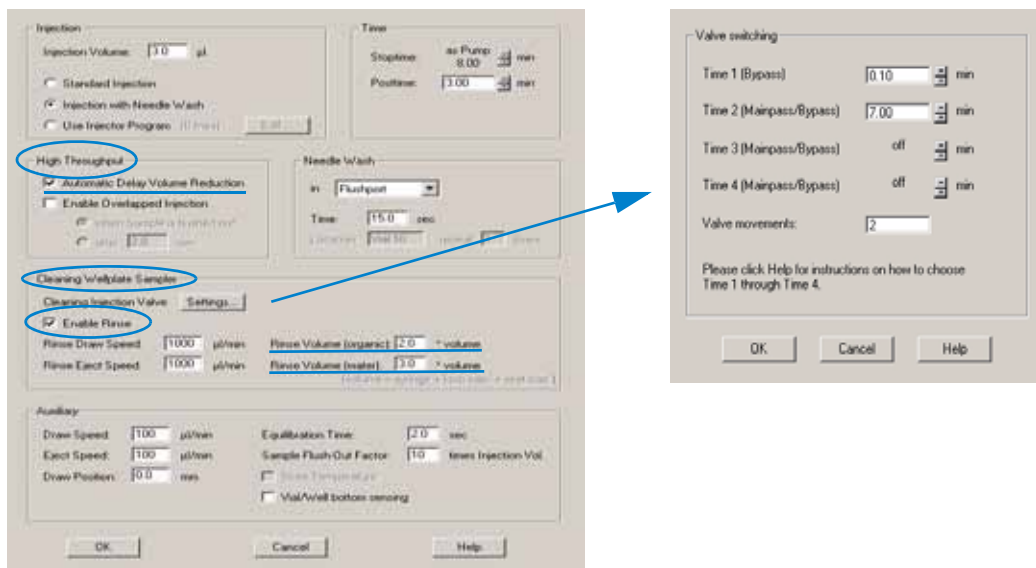

Figure 4 Wellplate Autosampler Settings in the ChemStation

The volume of strong and weak solvent, that should be used for the purging must be entered in the Settings. The time parameters determine when the injection system is cleaned with the strong solvent and when rinsing with the weak solvent should start, see Figure 4.

Figure 4 shows parameters settings for a typical reversed phase analysis, so that lowest carry over can be obtained for a gradient analysis, which is finished at 8min. The rinsing takes place during the runtime and no additional cycle time is needed.

High Throughput Settings

The Wellplate Autosampler Purge Kit is normally used in combination with the Automatic Delay Volume Reduction (ADVR) or Overlapped Injection (OI).

Settings for Automatic Delay Volume Reduction (ADVR)

The automatic delay volume reduction feature switches the injection valve to the bypass, when the sample is flushed out. The switching times are determined, either using a fixed time after the injection or depending on the flush out factor (calculated depending on injection volume, internal volumes between the needle tip and sampler

outlet at the injection valve and the used flow rate). If this option is selected the next sample is drawn, when the rinse cycles are finished. When this option is used, the "Flush-Out Factor must be entered in the More-Settings of the Autosampler.

Settings for Overlapped Injection (OI), using the Purge Valve

In overlapped injection the time for drawing the sample for the next injection can be determined in 2 ways:

One way is to select to select "**When sample is flushed out**". If this option is selected the next sample is drawn, when the rinse cycles are finished. When this option is used, the "**Flush-Out Factor**" must be entered in the More-Settings of the Autosampler.

A second way is to select a time under "**After**". At the selected time the rinse cycle starts and having finished the cleaning process the next sample is drawn.

Cleaning Wellplate Sampler Settings

Settings for Rinsing Parameters

In the Wellplate Autosampler Settings under "**Cleaning Wellplate sampler**" the "**Enable Rinse**" has to be selected, to activate the rinsing part of the method. The "**Rinse draw speed**" and the "**Rinse eject speed**" determine how fast the rinse solvents are drawn and ejected by the metering device.

Rinse speeds of 1 ml/min. are recommended for standard applications, a rinse cycle will then take about 0.75 min. For fast applications between 2 and 5 min. the speed can be increased to 2.5 ml/min. A cycle then takes about 0.4 min.

The "**Rinse Volume (organic) * volume**", i.e. the strong solvent for RP chromatography and the "**Rinse Volume (water) * volume**", i.e. the weak solvent for RP chromatography determine how many times the volume is flushed from the new G1156A 6-Position/7-Port Valve through injection valve, metering, sample loop, needle and seat out through the injection valve, again.

Injection Valve Cleaning Parameters

The times for the rinsing are set under "**Cleaning Injection Valve**" - SETTINGS. An additional screen pops up and the times can be set.

"**Time 1**" determines at what time the injection valve is switched into the bypass position after the sample from the previous injection has been flushed out. The sampler is flushed with the strong, normally organic (for RP analyses), solvent. In the bypass position the autosampler is no longer in the flow path and the pump eluent flows directly to the column, bypassing the Wellplate Autosampler.

"**Time 2**" determines when the injection valves is switched to mainpass and immediately back to bypass. This ensures, that the valve grooves are cleaned at a high organic percentage of the gradient. If this is done the autosampler is flushed with the weak solvent, normally water (for RP analyses) or start conditions of the gradient.

The valve can be switched more often using "**Time 3**" and "**Time 4**" if needed for cleaning or for filling the valve grooves with water or start gradient conditions.

Under "Valve Movements" the number of switching events at the set times can be determined, 2 are the maximum. This to safe the valve from having to many switches, which reduces lifetime of the valve.

NOTE

Please refer also to *Agilent ChemStation's Online Help* for more information about setting and optimizing the other Wellplate Autosampler operating parameters.

Control Module Operation

For accessing the **More Settings - Rinse of the Wellplate Autosampler**, start from the **ANALYSIS** View, press **F1 (Settings)** and select the Wellplate Autosampler. In the upcoming **Setting** screen, press **F1**, again. This will give access to the **<More Autosampler - Settings>** with parameters such as "Draw/Eject Speed", "Draw Position Offset", "Needle Wash Settings", "High Throughput" options like "Automatic Delay Volume Reduction" (ADVR) and "Overlapped Injection" (OI), the "Flush out Factor" and "Rinse".

NOTE

If "High Throughput" options like "Automatic Delay Volume Reduction" (ADVR) and "Overlapped Injection", are used in combination with the Wellplate Autosampler Purge kit, the time for switching into the "Bypass Mode" or the "Flush out Factor" must also be entered in the Settings!

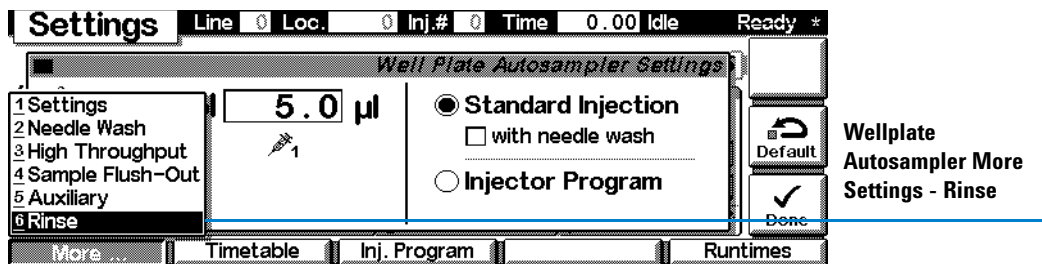

Figure 5 Wellplate Autosampler More Settings - Rinse in the Control Module

By selecting "Rinse", the use of the Injector Purge kit can be enabled and the volumes and draw speeds can be entered.

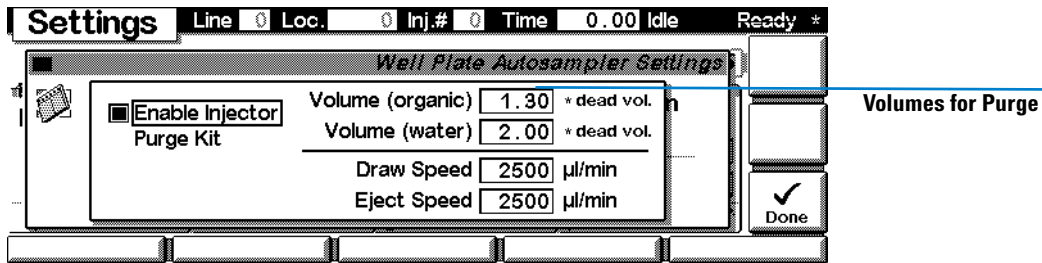

Figure 6 Wellplate Autosampler More Settings - Rinse in the Control Module

Here, you can enter the volume for the organic (strong solvent in RP analysis) and the volume for the water (weak solvent in RP analysis). The entered number determines, how many times the volume from the volume is flushed from the new G1156A 6-Position/7-Port Valve through injection valve, metering, sample loop, needle and seat out through the injection valve, again.

The "**Rinse draw speed**" and the "**Rinse eject speed**" determine how fast the rinse solvents are drawn and ejected by the metering device.

Rinse speeds of 1ml/min are recommended for standard applications, a rinse cycle will then take about 0.75min. For fast applications between 2 and 5 min the speed can be increased to 2.5ml/min. A cycle then takes about 0.4min.

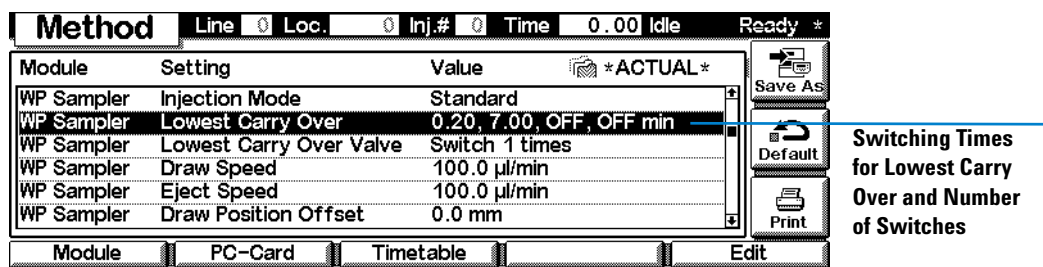

Figure 7 Rinse Parameter Settings in the Method Table of the Control Module

In addition, the Switching times (Time 1, Time 2, Time 3 and Time 4) and the number of Injection valve switches must be entered into the Method Table.

From the **ANALYSIS-View**, press **F3 (Method)** to access the Method Table. Using the **Up** and **Down** arrow, scroll down to the rows for "**Lowest Carry Over**". When the right line is reached, press **Enter** to access and modify the parameters.

In the "**Lowest Carry Over**"-line, the times for switching the injection valve (Time 1, Time 2, Time 3 and Time 4) can be entered, In the "**Lowest Carry Over Valve**"-line, the number of switches of the injection valve (max. 2) can be entered.

"**Time 1**" determines at what time the injection valve is switched into the bypass position after the sample from the previous injection has been flushed out. The sampler is flushed with the strong, mostly organic, solvent. In the bypass position the autosampler is no longer in the flow path and the pump eluent flows directly to the column, bypassing the Wellplate Autosampler.

"**Time 2**" determines when the injection valves is switched to mainpass and immediately back to bypass. This ensures, that the valve grooves are cleaned at a high organic percentage of the gradient. If this is done the autosampler is flushed with the weak solvent, mostly water or start conditions of the gradient.

The valve can be switched more often using "**Time 3**" and "**Time 4**" if needed for cleaning or for filling the valve grooves with water or start gradient conditions.

NOTE

Please refer also to the *Control Module's Online Help* for more information about setting and optimizing the other Wellplate Autosampler operating parameters.

G1373A Wellplate Autosampler Purge Kit Parts

Table 2 Wellplate Autosampler Purge Kit Parts for G1367A, G1368A Agilent 1100 Series Standard and Thermostatted Wellplate Autosamplers

| | Description | Part Number |
|----|--|--------------|
| 1 | Plastic cover cabinet kit with rail (includes top and side covers and the bolt carrier for mounting the front door). | 5065-9973 |
| 2 | 6-Position-7-Ports 1100 Series CAN valve Assay (Reorder number, for repairs, only) | G1156-60001 |
| 3 | Stator for G1156A valve | 0101-1410 |
| 4 | 1-Groove Rotor seal for G1156A valve | 0101-1411 |
| 5 | Wellplate Autosampler Purge Accessory kit (not orderable separately), includes items 6-22 | G1373-68705, |
| 6 | 2x Solvent bottle, clear glass, 1l | 9301-1420 |
| 7 | 2x Bottle head assembly | G1311-60003 |
| 8 | Tubing Set 100 cm (2x, for solvent connection from degasser to the purge valve) | G1373-67300 |
| 9 | 2x PEEK Adapter for tubing from degasser to valve port | 0100-1847 |
| 10 | Blanking Nut SST | 01080-83202 |
| 11 | Flexible Capillary 0.25 mm ID, length 320 mm | 5065-9980 |
| 12 | 1/16" front ferrules for SST capillaries, 1/16" back ferrules for SST capillaries, Fitting Screw long, pack of 10 | 5065-4454 |
| 13 | 3-groove Rotor seal for max. 600 bar (G1367A WPS injection valve, purge kit setup) | 0101-1409 |
| 14 | Restriction capillary for injection valve waste outlet | G1373-87300 |
| 15 | CAN cable, 1 m long (for 1100 Series module to module CAN connections) | 5181-1519 |
| 16 | DC CAN cable (to supply power to the G1156A valve from e.g. the G1367A WP-ALS) | 5181-1533 |
| 17 | Rheotool socket wrench | 8710-2391 |
| 18 | 9/64" Hex key driver | 8710-2394 |
| 19 | Priming Syringe (for solvent inlet tubing, reorder number, pack of 10) | 5062-8534 |
| 20 | Syringe Adapter for priming syringe | 9301-1337 |
| 21 | ChemStation CD ROM Rev. B.01.03 or higher for the use of this kit | N/A |
| 22 | Installation Note (this note) | N/A |

