

942 Extension Module Vario



942 Extension Module Vario Prep 2

Manual

8.942.8001EN / 2017-08-31



Metrohm AG
CH-9100 Herisau
Switzerland
Phone +41 71 353 85 85
Fax +41 71 353 89 01
info@metrohm.com
www.metrohm.com

942 Extension Module Vario

942 Extension Module Vario Prep 2

2.942.0020

Manual

Technical Communication
Metrohm AG
CH-9100 Herisau
techcom@metrohm.com

This documentation is protected by copyright. All rights reserved.

This documentation has been prepared with great care. However, errors can never be entirely ruled out. Please send comments regarding possible errors to the address above.

Table of contents

1	Introduction	1
1.1	Instrument description	1
1.2	Intended use	2
1.3	About the documentation	2
1.3.1	Content and scope	2
1.3.2	Symbols and conventions	2
1.4	Safety instructions	3
1.4.1	General notes on safety	3
1.4.2	Electrical safety	4
1.4.3	Tubing and capillary connections	5
1.4.4	Flammable solvents and chemicals	5
1.4.5	Recycling and disposal	5
2	Overview of the instrument	6
2.1	Front	6
2.2	Rear	7
2.3	Extension Module and 940 Professional IC Vario	7
3	Installation	9
3.1	Installation diagram	9
3.2	Setting up the instrument	10
3.2.1	Packaging	10
3.2.2	Checks	10
3.2.3	Location	10
3.3	Base tray and bottle holder	10
3.3.1	Basic information on base tray and bottle holder	10
3.3.2	Mounting base tray and bottle holder (optional)	11
3.4	Peristaltic pump	16
3.4.1	Installing the peristaltic pump	16
3.4.2	Mode of operation for the peristaltic pump	20
3.5	Installing the 6-port valve	21
3.6	Connecting an Extension Module	22
4	Start-up	23
5	Operation and maintenance	24
5.1	Servicing the door	24
5.2	Peristaltic pump	24
5.2.1	Notes on operating the peristaltic pump	24



5.2.2	Servicing the peristaltic pump	25
6	Quality management and qualification with Metrohm	27
7	Troubleshooting	28
7.1	Problems and their solutions	28
8	Technical specifications	29
8.1	Reference conditions	29
8.2	Ambient conditions	29
8.3	Housing	29
8.4	Weight	30
8.5	Peristaltic pump	30
8.6	6-port valve	30
8.7	Interfaces	30
9	Accessories	31
	Index	32



Table of figures

Figure 1	Front	6
Figure 2	Rear	7
Figure 3	Proposed setup	8
Figure 4	Installation diagram – inline matrix elimination	9
Figure 5	Peristaltic pump	20
Figure 6	6-port valve – Positions	21
Figure 7	Pump tubing connection – Replacing the filter	26

1 Introduction

1.1 Instrument description

942 Extension Module Vario are extension modules used to expand existing 940 Professional IC Vario instruments with additional functions. Each 940 Professional IC Vario instrument can be expanded with up to 3 942 Extension Module Vario instruments.

The **942 Extension Module Vario Prep 2** can be used to expand a 940 Professional IC Vario by adding sample preparation options, such as matrix elimination with transfer method or standard addition with preconcentration.

The 942 Extension Module Vario is operated using **MagIC Net** software, just like the IC instrument. If a 942 Extension Module Vario is connected to a 940 Professional IC Vario instrument, MagIC Net automatically detects the 942 Extension Module Vario and checks its functional capability. It controls and monitors the entire IC system including all connected instruments; it evaluates the measured data and manages it in a database.

The 942 Extension Module Vario Prep 2 consists of the following components:

Peristaltic pump

The peristaltic pump is used for pumping sample and auxiliary solutions. It can rotate in both directions.

6-port valve

The 6-port valve mimics the injection valve in its design. It is used during sample preparation. The 6-port valve serves as a switch-over point between two different liquids, such as switching between sample and auxiliary solution during Inline Matrix Elimination.



1.2 Intended use

The 942 Extension Module Vario Prep 2 expands an IC system by adding sample preparation options, such as inline dialysis.

This instrument is suitable for processing chemicals and flammable samples. Usage of the 942 Extension Module Vario Prep 2 therefore requires the user to have basic knowledge and experience in handling toxic and caustic substances. Knowledge regarding the application of fire prevention measures prescribed for laboratories is also mandatory.

1.3 About the documentation



CAUTION

Read through this documentation carefully before putting the instrument into operation. The documentation contains information and warnings which the user must follow in order to ensure safe operation of the instrument.

1.3.1 Content and scope

This document describes the **942 Extension Module Vario Prep 2** (2.942.0020), its assembly and connection to the IC instrument, as well as the installation, operation and maintenance of individual components. Information on technical specifications, troubleshooting, the scope of delivery and optional accessories make up the rest of the manual.

However, this document does not describe the functions of a unit combining a 940 Professional IC Vario and 942 Extension Module Vario Prep 2, nor does it describe the capillary connections that go beyond the 942 Extension Module Vario Prep 2. Refer to the manual for the 940 Professional IC Vario and Sample Processor in this regard.

Additional information concerning the configuration of MagIC Net can be found in the online help for MagIC Net.







1.3.2 Symbols and conventions

The following symbols and formatting may appear in this documentation:

(5-12)

Cross-reference to figure legend

The first number refers to the figure number, the second to the instrument part in the figure.

1	Instruction step Carry out these steps in the sequence shown.
Method	Dialog text, parameter in the software
File ▶ New	Menu or menu item
[Next]	Button or key
	WARNING This symbol draws attention to a possible life-threatening hazard or risk of injury.
	WARNING This symbol draws attention to a possible hazard due to electrical current.
	WARNING This symbol draws attention to a possible hazard due to heat or hot instrument parts.
	WARNING This symbol draws attention to a possible biological hazard.
	CAUTION This symbol draws attention to possible damage to instruments or instrument parts.
	NOTE This symbol highlights additional information and tips.

1.4 Safety instructions

1.4.1 General notes on safety



WARNING

This instrument may only be operated in accordance with the specifications in this documentation.

This instrument has left the factory in a flawless state in terms of technical safety. To maintain this state and ensure non-hazardous operation of the instrument, the following instructions must be observed carefully.



1.4.2 Electrical safety

The electrical safety when working with the instrument is ensured as part of the international standard IEC 61010.



WARNING

Only personnel qualified by Metrohm are authorized to carry out service work on electronic components.



WARNING

Never open the housing of the instrument. The instrument could be damaged by this. There is also a risk of serious injury if live components are touched.

There are no parts inside the housing which can be serviced or replaced by the user.

Supply voltage



WARNING

An incorrect supply voltage can damage the instrument.

Only operate this instrument with a supply voltage specified for it (see rear panel of the instrument).

Protection against electrostatic charges



WARNING

Electronic components are sensitive to electrostatic charges and can be destroyed by discharges.

Do not fail to pull the power cord out of the power socket before you set up or disconnect electrical plug connections at the rear of the instrument.

1.4.3 Tubing and capillary connections



CAUTION

Leaks in tubing and capillary connections are a safety risk. Tighten all connections well by hand. Avoid applying excessive force to tubing connections. Damaged tubing ends lead to leakage. Appropriate tools can be used to loosen connections.

Check the connections regularly for leakage. If the instrument is used mainly in unattended operation, then weekly inspections are mandatory.

1.4.4 Flammable solvents and chemicals



WARNING

All relevant safety measures are to be observed when working with flammable solvents and chemicals.

- Set up the instrument in a well-ventilated location (e.g. fume cupboard).
- Keep all sources of flame far from the workplace.
- Clean up spilled liquids and solids immediately.
- Follow the safety instructions of the chemical manufacturer.

1.4.5 Recycling and disposal

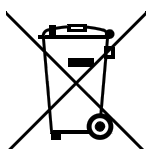

This product is covered by European Directive 2012/19/EU, WEEE – Waste Electrical and Electronic Equipment.

The correct disposal of your old instrument will help to prevent negative effects on the environment and public health.

More details about the disposal of your old instrument can be obtained from your local authorities, from waste disposal companies or from your local dealer.



2 Overview of the instrument

2.1 Front

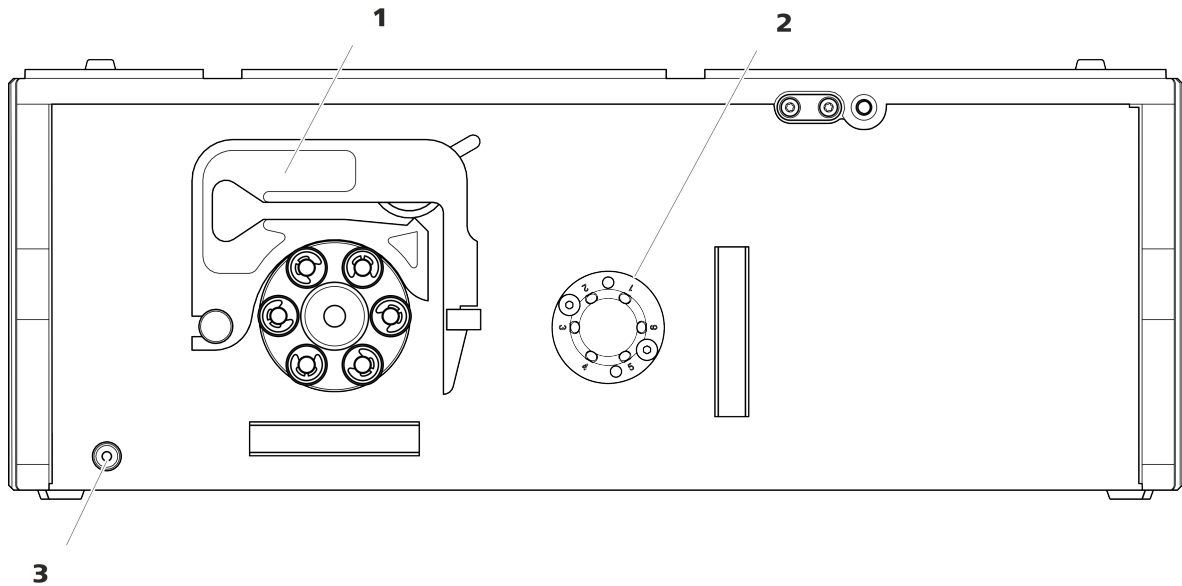

Figure 1 Front

1 Peristaltic pump

2 Switching valve

3 Standby indicator

2.2 Rear

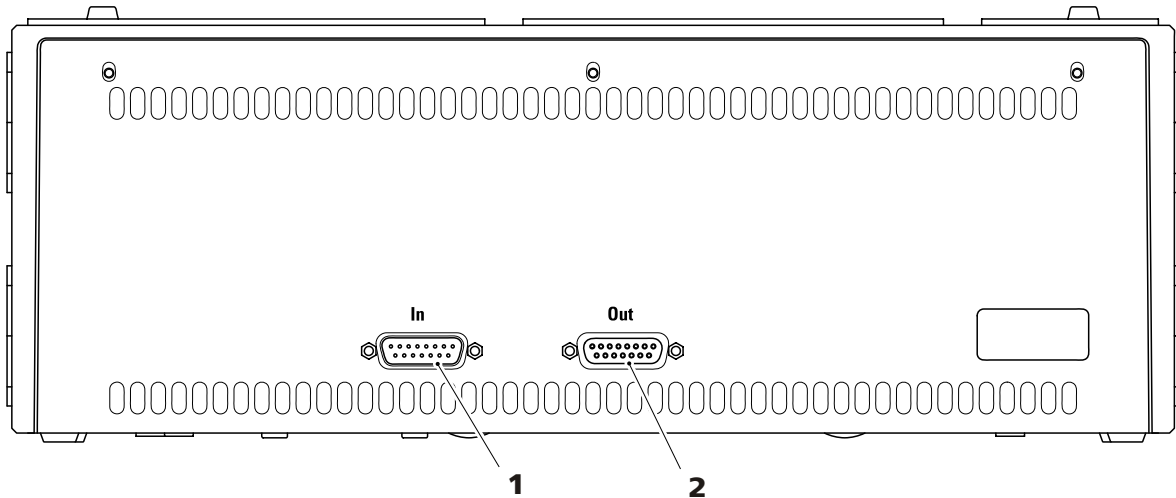

Figure 2 Rear

1 In connection

To connect the Extension Module to the IC instrument or to a previous Extension Module.

2 Out connection

To connect an additional Extension Module.

2.3 Extension Module and 940 Professional IC Vario

The 942 Extension Module Vario units are fitted directly to the 940 Professional IC Vario and connected to it via the connection cable provided. Extension modules have no power supply of their own, but rather draw the electricity they require from the instrument to which they are connected.

Extension modules can be placed in 3 different ways:

- Installed between the instrument and bottle holder (**3-A**).
- Installed between the instrument and base tray (**3-B**).
- Stacked next to the instrument (**3-C**). In this case, we recommend ordering a separate base tray (6.2061.110) and a separate bottle holder (6.2061.100) for the stack.

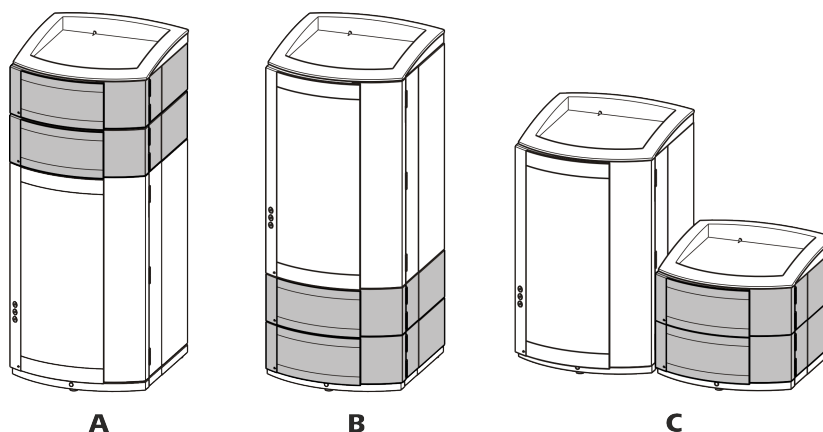

Figure 3 Proposed setup

A Extension module on top

Between the 940 Professional IC Vario and the bottle holder.

B Extension module below

Between the base plate and the 940 Professional IC Vario.

C Extension module separately

Next to the 940 Professional IC Vario with its own base plate and bottle holder.

Up to three extension modules can be connected to an 940 Professional IC Vario. The following restrictions are to be taken into account:

Restrictions

Together, the 940 Professional IC Vario and its extension modules must not contain more than 4 identical components, this means that:

- A maximum of 4 high-pressure pumps,
 - A maximum of 4 peristaltic pumps,
 - A maximum of 4 injection valves,
 - A maximum of 4 suppressors (MSM, incl. SPM),
- BUT**
- Only a maximum of 3 degassers
 - And a maximum of 3 CO₂ suppressors (MCS)



NOTE

If all four high-pressure pumps are being used simultaneously, then all of them must not be operating with their maximum flow for long periods.

Position the Extension Module in such a way that the capillary connections can be kept as short as possible. If several extension modules are being used, they should all be installed at the same location above or below each other. If this is not possible, extension modules that are farther apart have to be connected together using a longer connecting cable (6.2156.070).

3 Installation

3.1 Installation diagram

Depending on the application, the peristaltic pump and the 6-port valve of the 942 Extension Module Vario Prep 2 can be installed differently. *Figure 4: Installation diagram – inline matrix elimination* shows an example of how the peristaltic pump and the 6-port valve can be used for inline matrix elimination.

The graphic arrangement of the modules corresponds to the front of the Extension Module. The liquid containers, Sample Processor and IC instrument are not shown in the diagram.

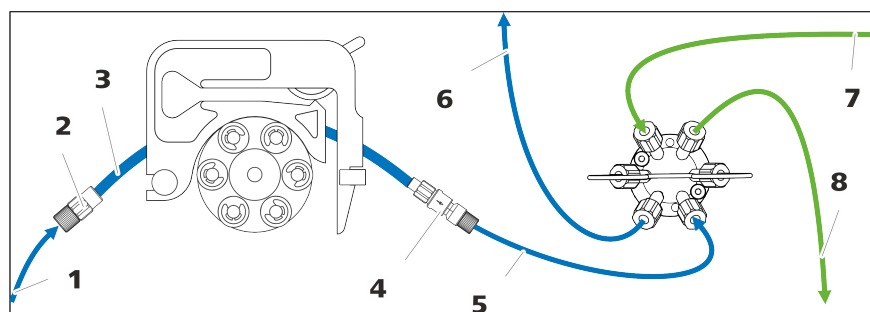

Figure 4 Installation diagram – inline matrix elimination

1	Aspiration capillary for transfer solution	2	Tubing olive (6.2744.034) With pressure screw.
3	Pump tubing	4	Pump tubing connection with locking nut and filter (6.2744.180) With pressure screw.
5	Transfer solution Connection to 6-port valve.	6	Transfer solution Connection to injection valve on ion chromatograph.
7	Sample Connection to Sample Processor.	8	Sample Connection to waste.



3.2 Setting up the instrument

3.2.1 Packaging

The instrument is supplied in protective packaging together with the separately packed accessories. Keep this packaging, as only this ensures safe transportation of the instrument.

3.2.2 Checks

Immediately after receipt, check whether the shipment has arrived complete and without damage by comparing it with the delivery note.

3.2.3 Location

The instrument has been developed for operation indoors and may not be used in explosive environments.

Place the instrument in a location of the laboratory which is suitable for operation, free of vibrations, protected from corrosive atmosphere, and contamination by chemicals.

The instrument should be protected against excessive temperature fluctuations and direct sunlight.

3.3 Base tray and bottle holder

3.3.1 Basic information on base tray and bottle holder

The base tray (6.2061.110) and bottle holder (6.2061.100) protect IC instruments from dust, dirt and leaking fluids. The supply bottles for eluent and auxiliary solutions can be positioned neatly on the bottle holder.

In a complex IC system, several different instruments may be used, such as an analyzer, an extension module and a detector. These instruments can be set up in one or more stacks. We recommend that a base tray and bottle holder be mounted for each stack of IC instruments.

The bottle holder and base tray must be removed or set up every time one of the following instruments is to be mounted on or under a 940 Professional IC Vario:

- One or more 942 Extension Module Vario.
- Or another instrument with the same-sized footprint.

3.3.2 Mounting base tray and bottle holder (optional)

The base tray and bottle holder come fully assembled on a new ion chromatograph. If you wished to install an extension module on the ion chromatograph, you would have to remove the bottle holder and put it back on top of the topmost instrument. If you wished to install an extension module below the ion chromatograph, you would have to remove the base tray and set it under the lowest instrument.

3.3.2.1 Removing/mounting the base tray

The base tray must be removed if you want to install another instrument under the IC instrument.



CAUTION

Do not allow capillaries or leak sensor cables to be pinched!

Pinches in the leak sensor cable or the capillaries fed through the guide ducts between the base tray and the instrument may lead to malfunctions.

Unplug the leak sensor cable. Remove all of the capillaries from the capillary ducts.

Removing the base tray

Before you can remove the base tray, the following preconditions must be met:

- The instrument is switched off.
- The bottle holder is cleared.
- All of the cable connections on the rear have been disconnected.
- The capillaries are removed from the guide ducts between the instrument and the base tray.
- There are no loose parts in the instrument.

To remove the base tray, you need a 3 mm hex key (6.2621.100).

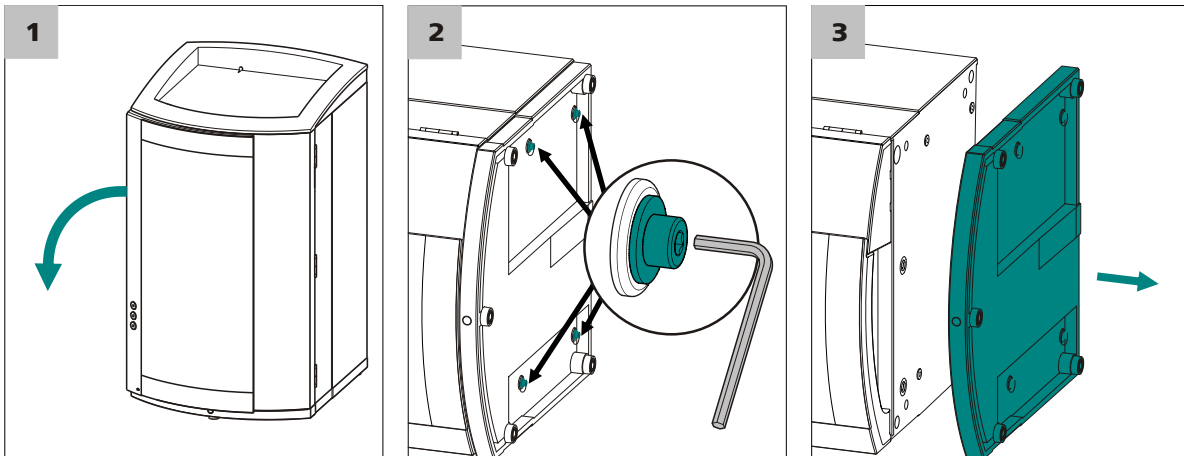

- 1** Tilt the instrument sideways and lay it down flat.
- 2** Loosen the four cylinder screws with the 3 mm hex key and remove them and their washers.
- 3** Remove the base tray.

The base tray must always be mounted under the lowermost instrument of the stack.

Mounting the base tray

Before you can mount the base tray, the following preconditions must be met:

- The instrument is switched off.
- The bottle holder is cleared.
- All of the cable connections on the rear have been disconnected.
- There are no loose parts in the instrument.
- The instrument is lying on its side, and the bottom surface is visible.

To mount the base tray, you need a 3 mm hex key (6.2621.100).

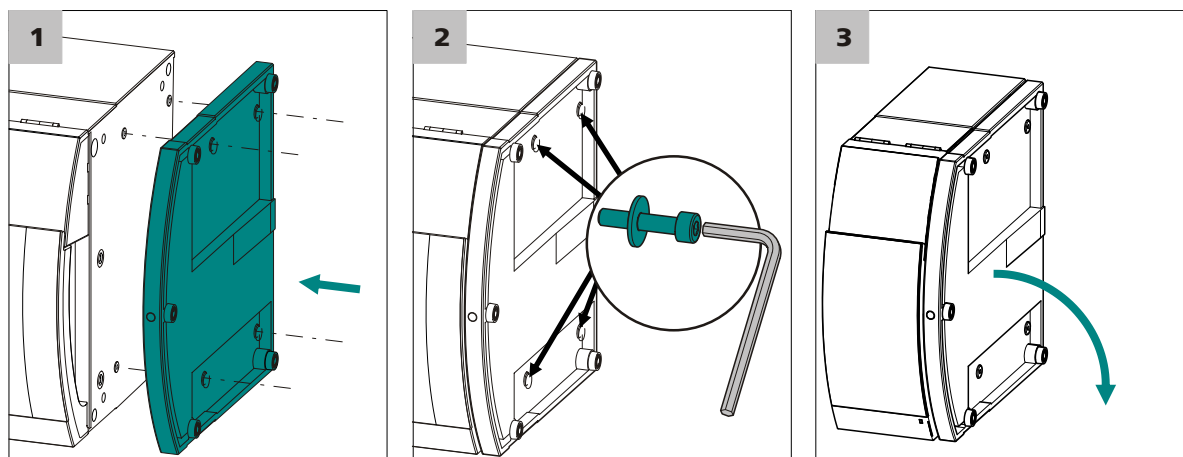

- 1 Place the base tray in such a way that the openings in the base tray match exactly the screw threads in the bottom of the instrument.
- 2 Slide the washers onto the cylinder screws, insert the screws and tighten them with the 3 mm hex key.
- 3 Set the instrument back up on the base tray.

Stack other instruments in the required order. Mount the bottle holder (6.2061.100) onto the topmost instrument on the stack (see "Mounting the bottle holder", page 14).

3.3.2.2 Removing/mounting the bottle holder

The bottle holder must be removed if you want to install another instrument onto the IC instrument.

Removing the bottle holder

Before you can remove the bottle holder, the following preconditions must be met:

- The instrument is switched off.
- The bottle holder is cleared.
- Drainage tubing is disconnected from the drainage tubing connection of the bottle holder.
- The capillaries are removed from the guide ducts between the instrument and the bottle holder.

To remove the bottle holder, you need a 3 mm hex key (6.2621.100).

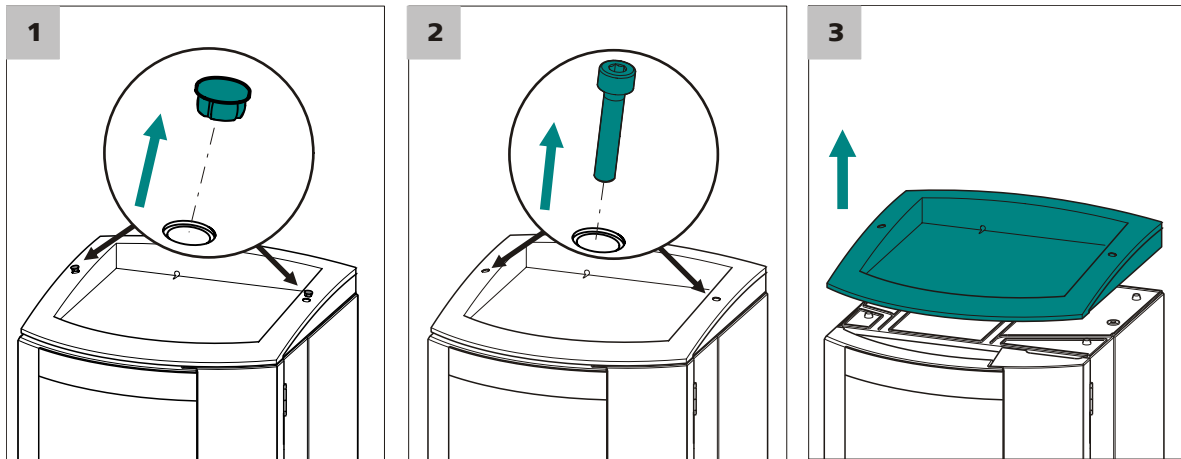

1 Remove the two covering stoppers.

2 Loosen the two cylinder screws with the 3 mm hex key and remove them.

3 Remove the bottle holder.

Stack other instruments in the required order. Mount the bottle holder (6.2061.100) onto the topmost instrument on the stack.

Mounting the bottle holder

Before you can mount the bottle holder, the following preconditions must be met:

- The instrument is switched off.

To mount the bottle holder, you need a 3 mm hex key (6.2621.100).

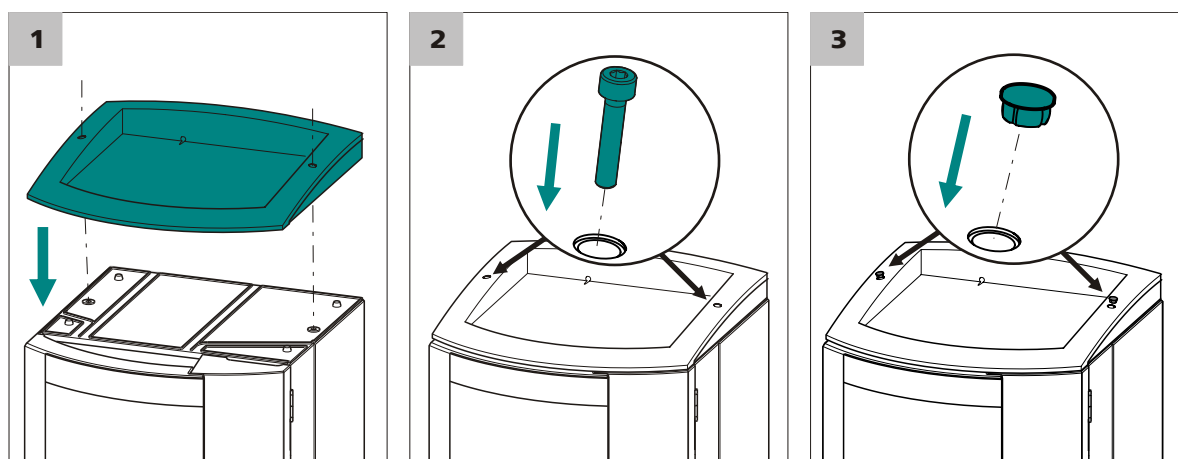

- 1 Place the bottle holder onto the topmost instrument in such a way that the openings in the bottle holder exactly match the screw threads on the top surface of the instrument.
- 2 Insert the two cylinder screws and tighten them with the 3 mm hex key.
- 3 Insert both covering stoppers.

After attaching the bottle holder, all connections that were undone at the beginning of the process must be reconnected.

Restoring the loosened connections

- 1 Plug in all necessary USB cables.
- 2 Plug in all necessary MSB cables.
- 3 Plug in the power supply cable.
- 4 Mount the drainage tubing again (*see manual of the IC instrument*).
A longer section of silicone tubing (6.1816.020) may have to be cut to size and mounted (*see also the manual for the IC instrument*).
- 5 If one of the instruments in the stack is equipped with a leak sensor connection socket, connect the leak sensor (*see manual of the IC instrument*).
- 6 Restore any capillary connections that may have been removed.



3.4 Peristaltic pump

3.4.1 Installing the peristaltic pump

Installing the pump tubing

Pump tubing can differ in terms of material, diameter and thus flow rate. Different pump tubing is used depending on the application.









Table 1 Pump tubings

Order number	Name	Material	Inner diameter	Use
6.1826.310	Pump tubing LFL (orange/green), 3 stoppers	PVC (Tygon®)	0.38 mm	Pump tubing for bromate determination using the triiodide method.
6.1826.320	Pump tubing LFL (orange/yellow), 3 stoppers	PVC (Tygon®)	0.48 mm	For acceptor solutions for Inline Dialysis and for Inline Ultrafiltration.
6.1826.330	Pump tubing LFL (orange/white), 3 stoppers	PVC (Tygon®)	0.64 mm	No special applications.
6.1826.340	Pump tubing LFL (black/black), 3 stoppers	PVC (Tygon®)	0.76 mm	For sample solution in Inline Dialysis.
6.1826.360	Pump tubing LFL (white/white), 3 stoppers	PVC (Tygon®)	1.02 mm	For sample transfer.
6.1826.380	Pump tubing LFL (gray/gray), 3 stoppers	PVC (Tygon®)	1.25 mm	For Inline Dilution.
6.1826.390	Pump tubing LFL (yellow/yellow), 3 stoppers	PVC (Tygon®)	1.37 mm	For sample solution in Inline Ultrafiltration.
6.1826.420	Pump tubing PharMed® (orange/yellow), 3 stoppers	Ismaprene	0.51 mm	For suppressor solutions.

Selecting the pump tubing and adapter

- 1 Select pump tubing suitable for the application (*see Table 1, page 16*).
- 2 Select an adapter suitable for the pump tubing. The adapters are included with the pump tubing connection with locking nut and filter (6.2744.180).

Table 2 Pump tubing and suitable adapters

Pump tubing	Adapter
6.1826.310 (orange/green)	
6.1826.320 (orange/yellow)	
6.1826.330 (orange/white)	
6.1826.340 (black/black)	
6.1826.360 (white/white)	
6.1826.380 (gray/gray)	
6.1826.390 (yellow/yellow)	
6.1826.420 (orange/yellow)	

Installing the pump tubing

For this step, you need the following accessories:

- Tubing cartridge (6.2755.000)
- Pump tubing (6.1826.XXX)
- Coupling olive/UNF 10/32 (6.2744.034)
- Pump tubing connection with locking nut and filter (6.2744.180):
Includes a locknut, 3 adapters and a tubing olive with filter holder.
- 2 × pressure screw, short (6.2744.070)

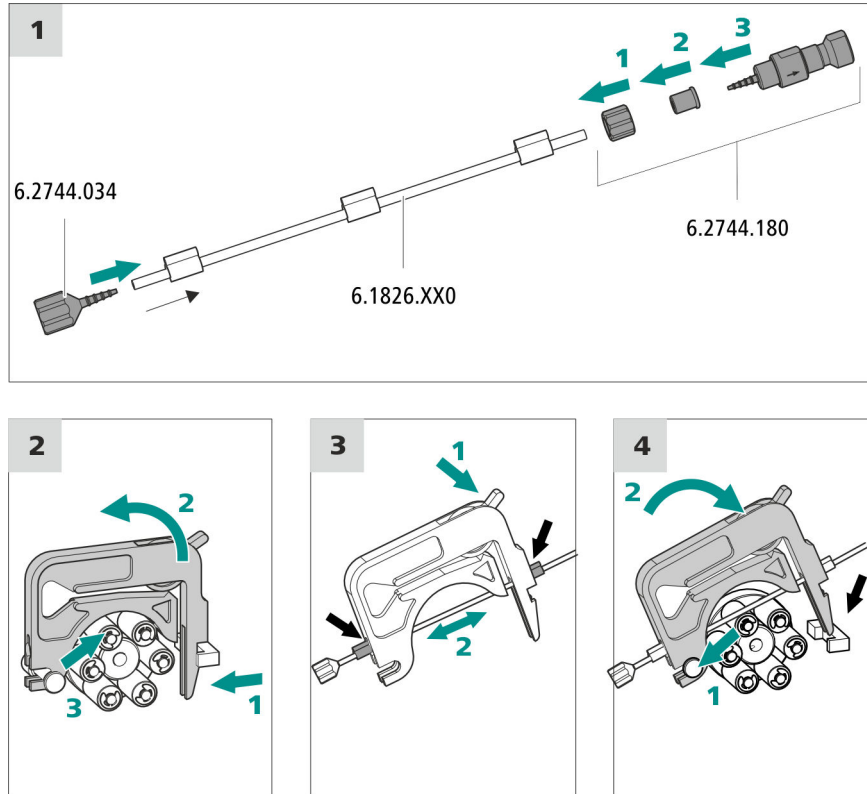

1 Connecting the pump tubing

- Attach the coupling olive/UNF 10/32 (6.2744.034) to the pump tubing entry. Push the end of the pump tubing over at least the second notch of the olive so that the pump tubing is firmly in place.
- Assemble the pump tubing connection with locking nut and filter (6.2744.180) at the pump tubing exit:
 - Push the locknut onto the pump tubing.
 - Push the appropriate adapter onto the pump tubing.
 - Place the tubing olive with the filter holder into the pump tubing so that the pump tubing is firmly in place; push the end of the pump tubing over at least the second notch of the olive.
 - Tighten it using the union nut.

2 Removing the tubing cartridge

- Press in the tubing cartridge's snap-action lever.
- Tilt the tubing cartridge upwards.
- Unhook the tubing cartridge from the mounting bolt.

3 Inserting the pump tubing

- Press the tubing cartridge's contact pressure lever down all the way.
- Place the pump tubing in the tubing cartridge. Fit the tubing cartridge between two stoppers. The stoppers must snap into the corresponding holder of the tubing cartridge.

4 Inserting the tubing cartridge

- Hang the tubing cartridge in the mounting bolt and press it in the cartridge holder until you hear the snap-action lever snap in.

Setting the flow rate

The flow rate of the peristaltic pump depends on many factors:

- The inner diameter of the pump tubing
- The rotational speed of the drive
- The contact pressure of the tubing cartridge



NOTE

Pieces of pump tubing are consumables. The service life of the pump tubing depends on the contact pressure, among other factors.

Setting the contact pressure correctly

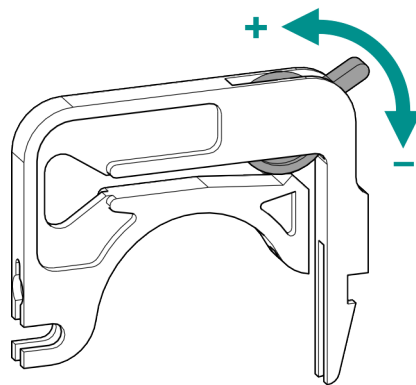

- 1 ▪ Fully loosen the contact pressure lever, i.e. press it all the way down.
 - In the software, activate the drive of the peristaltic pump with the desired speed.
 - Raise the contact pressure lever one step at a time until liquid flows.



- When liquid starts flowing, raise the contact pressure lever by an additional two ratchet increments.

The contact pressure is now set optimally.

3.4.2 Mode of operation for the peristaltic pump

The peristaltic pump is used for pumping sample and auxiliary solutions. It can rotate in both directions.

The peristaltic pump pumps liquids based on the principle of displacement. The pump tubing is clamped between the rollers (5-5) and the tubing cartridge (5-2). During operation, the peristaltic pump drive rotates the roller hub (5-6), so that the rollers (5-5) advance the liquid in the pump tubing.

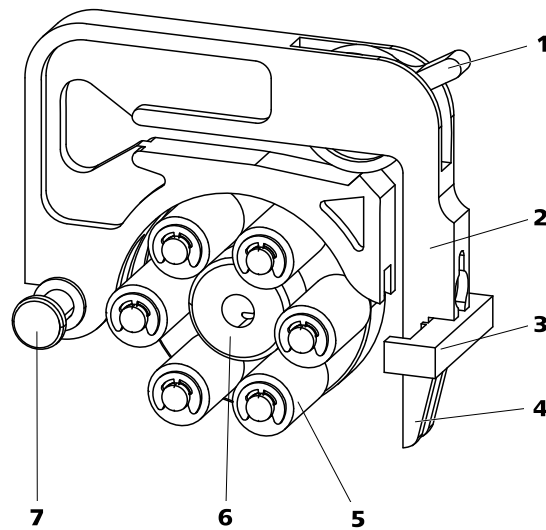

Figure 5 Peristaltic pump

1	Contact pressure lever	2	Tubing cartridge (6.2755.000)
3	Cartridge holder	4	Snap-action lever
5	Rollers	6	Roller hub
7	Mounting bolt		

3.5 Installing the 6-port valve

During sample preparation, the 6-port valve is used as a switch between two different flows.

Connectors

The 6-port valve (like the injection valve) has six connections that can be connected together depending on the application.

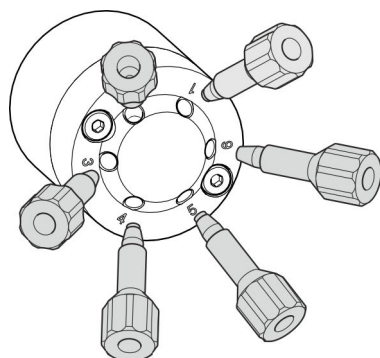

Connecting the 6-port valve

- 1 Connect all capillaries using PEEK pressure screws (6.2744.010).

Valve positions

The 6-port valve (see Figure 6, page 21) can have two valve positions: **Filling** and **Injecting**. Switching is used to connect two different connections together in each case.

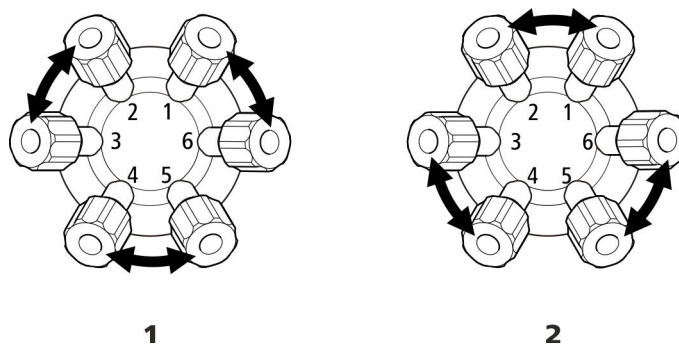

Figure 6 6-port valve – Positions

1 Fill

Filling

Injecting

2 Inject

Ports 2 and 3, 4 and 5 as well as 6 and 1 are connected together in the **Filling** position.

Ports 1 and 2, 3 and 4 as well as 5 and 6 are connected together in the **Injecting** position.



3.6 Connecting an Extension Module



CAUTION

The 940 Professional IC Vario **has to be switched off** when connecting the Extension Module!

Accessories

For this step you need the following accessories:

- 6.2156.060 cable Extension Module - Professional IC, 40 cm
or
- 6.2456.070 cable Extension Module - Professional IC, 1 m (optional accessory)

The connection sockets are located on the rear of the instrument.

Connecting the Extension Module to the IC instrument

- 1 Plug the connecting cable (6.2156.060) into the **In** connection socket on the Extension Module and tighten it in place.
- 2 Plug the other end of the connecting cable into the **Extension Module** connection socket on the IC instrument and tighten it in place.

Only one Extension Module can be connected directly to the IC instrument. The second Extension Module has to be connected to the first and the third to the second.

Connecting an Extension Module to another Extension Module

- 1 Plug the connecting cable (6.2156.060) or the longer connecting cable (6.2156.070) into the **In** connection socket on the second Extension Module and tighten it in place.
- 2 Plug the other end of the connecting cable into the **Out** connection socket on the first Extension Module and tighten it in place.

4 Start-up

The 942 Extension Module Vario Prep 2 is put into operation together with the IC instrument.

The following preconditions must be met before initial start-up:

- The peristaltic pump is installed and connected.
- The 942 Extension Module Vario Prep 2 is connected to the 940 Professional IC Vario.

You can find additional information on carrying out initial start-up in the *Start-up* chapter in the manual for the IC instrument and the MagIC Net online help.



5 Operation and maintenance

5.1 Servicing the door



CAUTION

The door is made of PMMA (poly(methyl methacrylate)). It must never be cleaned with abrasive media or solvents.



CAUTION

Never hold the instrument by the door when lifting it. Only hold the instrument by the housing.

5.2 Peristaltic pump

5.2.1 Notes on operating the peristaltic pump

The flow rate of the peristaltic pump depends on the drive speed (set using the software), the contact pressure and, above all, the inner diameter of the pump tubing. Depending on the application, different pump tubing is used. Select pump tubing that best matches your application (*see Table 1, page 16*).



CAUTION

The service life of the pump tubing primarily depends on the contact pressure.

If the peristaltic pump is switched off for long periods, lift up the tubing cartridges on the right side by releasing the snap-action levers. This ensures that the contact pressure will be maintained once it has been set.



CAUTION

The pump tubing (6.1826.xxx) is made of PVC or PP and therefore must not be used for rinsing with solutions containing organic solvents. In this case, use different pump tubing or use another pump for rinsing.

5.2.2 Servicing the peristaltic pump

5.2.2.1 Replacing the pump tubing

Pieces of pump tubing inserted into the peristaltic pump are consumables with a limited service life.

Pieces of pump tubing with 3 stoppers are tensioned in the tubing cartridge so that they end up positioned between two stoppers. This results in two possible positions for the tubing cartridge. Once the pump tubing exhibits significant signs of wear, it can be tensioned a second time in the other respective position.

Maintenance interval Replace the pump tubing every 2 months.

Replace the pump tubing every 4 weeks if the peristaltic pump is being used continuously.

5.2.2.2 Replacing the filter

The filters inserted into the pump tubing connection with locking nut and filter (6.2744.180) must be replaced regularly.

Maintenance interval We recommend replacing the filters (6.2821.130) (7-2) every three months. The filters may need to be replaced more frequently, depending on the application.

Accessories For this step, you need the following accessories:

- 1 filter from the spare filter set (6.2821.130)
- 2 adjustable wrenches (6.2621.000)
- Tweezers



Replacing the filter

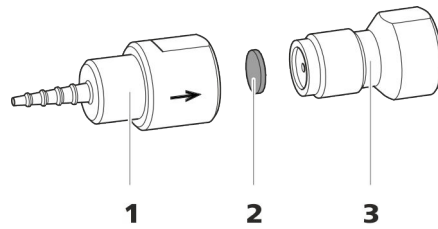

Figure 7 Pump tubing connection – Replacing the filter

1 Tubing olive

2 Filter (6.2821.130)
Pack contains 10 pieces.

3 Filter screw

1 Unscrewing the filter screw

- Unscrew the filter screw (7-3) from the tubing olive (7-1) using the two adjustable wrenches.

2 Replacing the filter

- Remove the old filter (7-2) using tweezers.
- Use tweezers to place the new filter (7-2) on the filter screw (7-3) so that it is **flat** and press it firmly into place with the rear of the tweezers.

3 Installing the filter screw

- Screw the filter screw (7-3) back into the tubing olive (7-1) and start by tightening it by hand. Finish tightening it using the two adjustable wrenches.

6 Quality management and qualification with Metrohm

Quality management

Metrohm offers you comprehensive support in implementing quality management measures for instruments and software.

Qualification

Please contact your local Metrohm representative for support in qualification of instruments and software. The **Installation Qualification** (IQ) and **Operational Qualification** (OQ) are offered by Metrohm representatives as a service. They are carried out by trained employees using standardized qualification documents and in accordance with the currently applicable requirements of the regulated industry.



7 Troubleshooting

7.1 Problems and their solutions

Problem	Cause	Remedy
The peristaltic pump is pumping too little.	<i>Peristaltic pump – Contact pressure too weak.</i>	Correctly set the contact pressure (see "Setting the contact pressure correctly", page 19).
	<i>Peristaltic pump – Filter blocked.</i>	Replace the filter (see "Replacing the filter", page 26).
	<i>Peristaltic pump – Pump tubing defective.</i>	Replace the pump tubing (see Chapter 5.2.2.1, page 25).

8 Technical specifications

8.1 Reference conditions

The technical specifications listed in this chapter refer to the following reference conditions:

<i>Ambient temperature</i>	+25 °C (± 3 °C)
<i>Instrument status</i>	Operating > 40 minutes (in equilibrium)

8.2 Ambient conditions

Operation

<i>Ambient temperature</i>	+5 - +45 °C
<i>Humidity</i>	20 - 80 % relative humidity

Storage

<i>Ambient temperature</i>	-20 - +70 °C
----------------------------	--------------

Transport

<i>Ambient temperature</i>	-40 - +70 °C
----------------------------	--------------

8.3 Housing

Dimensions

<i>Width</i>	365 mm
<i>Height</i>	131 mm
<i>Depth</i>	380 mm

<i>Material of base tray, housing and bottle holder</i>	Polyurethane hard foam (PUR) with flame retardation for fire class UL94V0, CFC-free, coated
---	---



8.4 Weight

2.942.0020 6.12 kg

8.5 Peristaltic pump

Type 2-channel peristaltic pump
Shift direction Clockwise/counterclockwise
Rotational speed 0 - 42 rpm in 7 levels of 6 rpm each
Pumping characteristics 0.3 mL/min at 18 rpm; with standard pump tubing (6.1826.420)
Pump tubing material Recommended: PharMed® (Ismaprene)

8.6 6-port valve

Actuator switching time typ. 100 ms
Maximum operating pressure 35 MPa (350 bar)
Material PEEK

8.7 Interfaces

In 1 15-pin D-sub plug (male)
 Connection to the ion chromatograph or another Extension Module.
Out 1 15-pin D-sub plug (female)
 Connection to another Extension Module or an 891 Professional Analog Out (optional).

9 Accessories

Up-to-date information on the scope of delivery and on optional accessories for your instrument can be found on the Internet. You can download this information using the article number as follows:

Downloading the accessories list

- 1 Type <https://www.metrohm.com/> into your Internet browser.
- 2 Under **Find products, accessories, and applications by**, enter the article number (e.g. **2.942.0020**).
The search result is displayed.
- 3 Under **Products**, click on **More information**.
Detailed information regarding the product is shown on various tabs.
- 4 On the **Included parts** tab, click on **Download the PDF**.
The PDF file with the accessories data will be created.



NOTE

When you receive your new instrument, we recommend downloading the accessories list from the Internet, printing it out and keeping it together with the manual for reference purposes.



Index

6-port valve	1
Fill	21
Inject	21
Installation	21
Technical specifications	30

A	
Ambient conditions	29

B	
Base tray	
Mount	12
Remove	11
Bottle holder	
Mount	14
Remove	13

D	
Diagram	
Installation	9
Dimensions	29
Door	24

E	
Electrostatic charge	4
Extension Module	
Connect	22

F	
Fill	
6-port valve	21
Front	6
Front of the instrument	6

H	
Housing	29
Humidity	29

I	
Inject	
6-port valve	21
Installation	
6-port valve	21
Peristaltic pump	16
Pump tubing	16
Installation diagram	9
Installation qualification	27
Instrument	
Front	6
Rear	7

M	
Maintenance	
Peristaltic pump	24
Maintenance agreement	27
Material	29

O	
Operation	
Peristaltic pump	24
Operational qualification	27
Overview of the instrument	6

P	
Peristaltic pump	
Installation	16
Maintenance	24
Mode of operation	20

Operation	24
Technical specifications	30
Pump tubing	
Install	16
Service life	24
Pump tubings	
Overview	16

Q	
Quality management	27

R	
Rear	7
Reference conditions	29
Rinse	
Pump tubing	24

S	
Safety instructions	3
Service	4
Storage	29
Supply voltage	4

T	
Technical specifications	
6-port valve	30
Peristaltic pump	30
Reference conditions	29
Temperature	29
Transport	29

V	
Valve	
Also see "6-port valve"	21