

940 Professional IC Vario



940 Professional IC Vario ONE/HPG

Manual

8.940.8004EN / 2017-07-31



Metrohm AG

CH-9100 Herisau

Switzerland

Phone +41 71 353 85 85

Fax +41 71 353 89 01

info@metrohm.com

www.metrohm.com

940 Professional IC Vario

940 Professional IC Vario ONE/HPG

2.940.1140

Manual

Technical Communication
Metrohm AG
CH-9100 Herisau
techcom@metrohm.com

This documentation is protected by copyright. All rights reserved.

This documentation has been prepared with great care. However, errors can never be entirely ruled out. Please send comments regarding possible errors to the address above.

Table of contents

1	Introduction	1
1.1	Instrument description	1
1.2	Intended use	3
1.3	Safety instructions	3
1.3.1	General notes on safety	3
1.3.2	Electrical safety	4
1.3.3	Tubing and capillary connections	5
1.3.4	Flammable solvents and chemicals	5
1.3.5	Recycling and disposal	5
1.4	Symbols and conventions	6
2	Overview of the instrument	7
2.1	Front	7
2.2	Rear	9
2.3	Feed-throughs for capillaries and cables	10
3	Installation	14
3.1	Setting up the instrument	14
3.1.1	Packaging	14
3.1.2	Checks	14
3.1.3	Location	14
3.2	Capillary connections in the IC system	14
3.3	Removing the handle	17
3.4	Removing transport locking screws	18
3.5	Connecting the drainage tubing and leak sensor	19
3.5.1	Installing the drainage tubing	19
3.5.2	Connecting the leak sensor	21
3.6	Column thermostat	21
3.7	Connecting the eluent bottle	22
3.8	Connecting the eluent degasser	26
3.9	Installing the high-pressure pump	26
3.10	Installing an inline filter	27
3.11	Installing the pulsation absorber	27
3.12	Injection valve	28
3.13	Installing the conductivity detector	30
3.14	Installing the amperometric detector	31



3.15	Connecting the sample degasser (optional)	31
3.16	Installing the high-pressure gradient module	33
3.17	Connecting the instrument to a computer	33
3.18	Connecting the instrument to the power grid	34
3.19	Initial start-up	35
3.20	Connecting and rinsing the guard column	37
3.21	Connecting the separation column	39
3.22	Conditioning	43
4	Operation	45
5	Operation and maintenance	46
5.1	IC system	46
5.1.1	Operation	46
5.1.2	Care	46
5.1.3	Maintenance by Metrohm Service	46
5.1.4	Shutting down and recommissioning	47
5.2	Capillary connections	48
5.3	Servicing the door	48
5.4	Column thermostat – Replacing the capillaries	48
5.5	Handling the eluent	50
5.5.1	Manufacturing eluent	50
5.5.2	Changing the eluent	51
5.6	Servicing the eluent degasser	51
5.7	Notes on operating the high-pressure pump	52
5.8	Servicing the high-pressure pump	53
5.9	Servicing the inline filter	66
5.10	Servicing the pulsation absorber	69
5.11	Injection valve	69
5.12	Servicing the detector	69
5.13	Rinsing the sample path	69
5.14	Separation column	71
5.14.1	Separating efficiency	71
5.14.2	Protecting the separation column	71
5.14.3	Storing the separation column	71
5.14.4	Regenerating the separation column	71
5.15	Quality management and qualification with Metrohm	72

6	Troubleshooting	73
6.1	73
7	Technical specifications	77
7.1	Reference conditions	77
7.2	Instrument	77
7.3	Ambient conditions	77
7.4	Housing	78
7.5	Weight	78
7.6	Leak sensor	78
7.7	Column thermostat	78
7.8	Eluent degasser	79
7.9	High-pressure pump	79
7.10	Injection valve	80
7.11	Detector	80
7.12	Sample degasser	80
7.13	Power connection	80
7.14	Interfaces	81
8	Accessories	82
	Index	83



Table of figures

Figure 1	Front	7
Figure 2	Rear	9
Figure 3	Feed-throughs on the door	11
Figure 4	Openings for capillaries and cables	12
Figure 5	Ducts for capillaries	13
Figure 6	Removing the transport locking screws	18
Figure 7	Installing the eluent bottle cap	22
Figure 8	Installing tubing weighting and aspiration filter	24
Figure 9	High-pressure pump with purge valve	26
Figure 10	Inline filter	27
Figure 11	Pulsation absorber	28
Figure 12	Exchanging the sample loop	29
Figure 13	Column thermostat	49
Figure 14	High-pressure pump – Parts	53
Figure 15	High-pressure pump – Cross-section	60
Figure 16	Tool for piston seal (6.2617.010)	61
Figure 17	Removing the piston cartridge from the pump head	61
Figure 18	Inserting the piston seal into the tool	62
Figure 19	Parts of the piston cartridge	63
Figure 20	Inline filter – Removing the filter	67

1 Introduction

1.1 Instrument description

The 940 Professional IC Vario is a professional ion chromatograph. It is distinguished by:

- Its intelligence: All of the functions are monitored, optimized and documented in an FDA-compatible manner. Intelligent components, such as iColumns, save important data onto a chip.
- Its compact design: It has a small footprint.
- Its modularity: It provides flexibility for use in various applications. It can hold up to three modules for different functions in its three drawers. Individual modules can be swapped or added as needed.
- Its transparency: All components are easily accessible and located for simple visibility and can be monitored during operation through a large window.
- Its safety: The design separates the wet end and the electronics, thereby preventing liquids from coming into contact with the electronics to a large extent. A leak sensor is integrated into the wet end.
- Its environmental compatibility.
- Its low noise emissions.
- The intelligent MagIC Net software

The 940 Professional IC Vario is operated solely using the MagIC Net software. A USB cable is used to connect the instrument to a computer with MagIC Net installed. The intelligent software detects the instrument automatically and checks its functionality. The software controls and monitors the instrument, evaluates the measured data and manages it in a database.

The 940 Professional IC Vario ONE/HPG consists of the following modules:

Housing

The sturdy housing contains the instrument's electronic components, including their interfaces and three connections for separation columns (two of which are built into the installed column thermostat). In addition, the housing provides space for two detectors (conductivity detectors or amperometric detectors) and up to three plug-ins with different functions. Capillaries and cables can be fed into and out of the instrument through several openings.

**Leak sensor**

The leak sensor detects leaking liquid that collects in the instrument's base tray. Liquid that leaks in the instrument is routed to the base tray using drainage tubing and detected there.

Column thermostat

The column thermostat regulates the temperature for the separation columns and the eluent, thereby providing stable measuring conditions. The interior of the column thermostat can be heated and cooled. There are two column holders with chip readers in the column thermostat.

Eluent degasser

The eluent degasser removes gas bubbles and dissolved gases from the eluent.

High-pressure pump

The intelligent and low-pulsation high-pressure pump pumps the eluent through the IC system. It is equipped with a chip where its technical specifications and "life history" (operating hours, service data, etc.) are stored.

Inline filter

Inline filters protect the separation column reliably from potential contamination from the eluent. The filter pads with 2 µm pore size can be replaced quickly and easily. They remove particles from the solutions, such as bacteria and algae.

Pulsation absorber

The pulsation absorber protects the separation column from damage caused by pressure fluctuations, e.g. when the injection valve is switched, and reduces interfering pulsations during highly sensitive measurements.

Injection valve

The injection valve connects the eluent path to the sample path. By a quick and precise switching of the valve, a quantity of sample solution defined by the size of the sample loop is injected and flushed to the separation column with the eluent.

Detector

Metrohm offers a series of different detectors for various analysis tasks. A suitable detector type must be ordered as a separate device.

Sample degasser

The sample degasser removes gas bubbles and dissolved gases from the sample.

High-pressure gradient module (HPG)

The second high-pressure pump in the instrument allows a gradient to be created from two eluents. The software is used to control the amount of eluent.

Separation column

The intelligent separation column separates different components according to their interactions with the column. Metrohm separation columns are equipped with a chip where their technical specifications and history (start-up, operating hours, injections etc) are stored.

1.2 Intended use

The 940 Professional IC Vario ONE/HPG is used for the determination of cations and anions without suppression using ion chromatography when the complex separation problem requires the use of gradients.

The second high-pressure pump in the lower plug-in allows for the controlled mixing of two eluents.

This instrument is suitable for processing chemicals and flammable samples. Usage of the 940 Professional IC Vario therefore requires the user to have basic knowledge and experience in handling toxic and caustic substances. Knowledge regarding the application of fire prevention measures prescribed for laboratories is also mandatory.

1.3 Safety instructions

1.3.1 General notes on safety



WARNING

This instrument may only be operated in accordance with the specifications in this documentation.

This instrument has left the factory in a flawless state in terms of technical safety. To maintain this state and ensure non-hazardous operation of the instrument, the following instructions must be observed carefully.



1.3.2 Electrical safety

The electrical safety when working with the instrument is ensured as part of the international standard IEC 61010.



WARNING

Only personnel qualified by Metrohm are authorized to carry out service work on electronic components.



WARNING

Never open the housing of the instrument. The instrument could be damaged by this. There is also a risk of serious injury if live components are touched.

There are no parts inside the housing which can be serviced or replaced by the user.

Supply voltage



WARNING

An incorrect supply voltage can damage the instrument.

Only operate this instrument with a supply voltage specified for it (see rear panel of the instrument).

Protection against electrostatic charges



WARNING

Electronic components are sensitive to electrostatic charges and can be destroyed by discharges.

Do not fail to pull the power cord out of the power socket before you set up or disconnect electrical plug connections at the rear of the instrument.

1.3.3 Tubing and capillary connections



CAUTION

Leaks in tubing and capillary connections are a safety risk. Tighten all connections well by hand. Avoid applying excessive force to tubing connections. Damaged tubing ends lead to leakage. Appropriate tools can be used to loosen connections.

Check the connections regularly for leakage. If the instrument is used mainly in unattended operation, then weekly inspections are mandatory.

1.3.4 Flammable solvents and chemicals



WARNING

All relevant safety measures are to be observed when working with flammable solvents and chemicals.

- Set up the instrument in a well-ventilated location (e.g. fume cupboard).
- Keep all sources of flame far from the workplace.
- Clean up spilled liquids and solids immediately.
- Follow the safety instructions of the chemical manufacturer.

1.3.5 Recycling and disposal

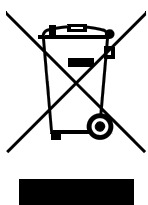

This product is covered by European Directive 2012/19/EU, WEEE – Waste Electrical and Electronic Equipment.







The correct disposal of your old instrument will help to prevent negative effects on the environment and public health.

More details about the disposal of your old instrument can be obtained from your local authorities, from waste disposal companies or from your local dealer.



1.4 Symbols and conventions

The following symbols and formatting may appear in this documentation:

<i>(5-12)</i>	Cross-reference to figure legend The first number refers to the figure number, the second to the instrument part in the figure.
1	Instruction step Carry out these steps in the sequence shown.
Method	Dialog text, parameter in the software
File ▶ New	Menu or menu item
[Next]	Button or key
	WARNING This symbol draws attention to a possible life-threatening hazard or risk of injury.
	WARNING This symbol draws attention to a possible hazard due to electrical current.
	WARNING This symbol draws attention to a possible hazard due to heat or hot instrument parts.
	WARNING This symbol draws attention to a possible biological hazard.
	CAUTION This symbol draws attention to possible damage to instruments or instrument parts.
	NOTE This symbol highlights additional information and tips.

2 Overview of the instrument

2.1 Front

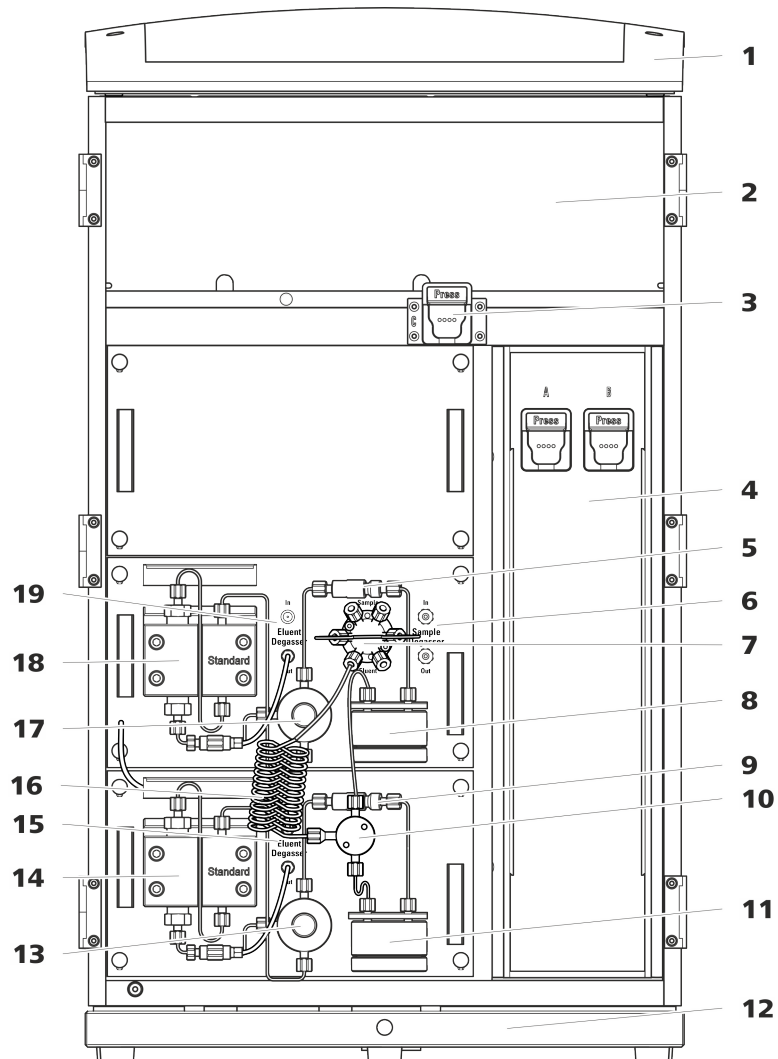

Figure 1 Front

1 Bottle holder

Offers space for the eluent bottle(s) and additional accessories.

3 Column holder

For a third separation column outside the column thermostat.

5 Inline filter

2 Detector chamber

Offers space for two embedded detectors and additional accessories.

4 Column thermostat

With two column holders for two separation columns.

6 Sample degasser



7	Injection valve	8	Pulsation absorber
9	Inline filter	10	T connector
11	Pulsation absorber	12	Base tray With leak sensor.
13	Purge valve For deaerating the high-pressure pump.	14	Gradient pump B
15	Eluent degasser	16	Mixing coil
17	Purge valve For deaerating the high-pressure pump.	18	Gradient pump A
19	Eluent degasser Removes air bubbles from the eluent.		

2.2 Rear

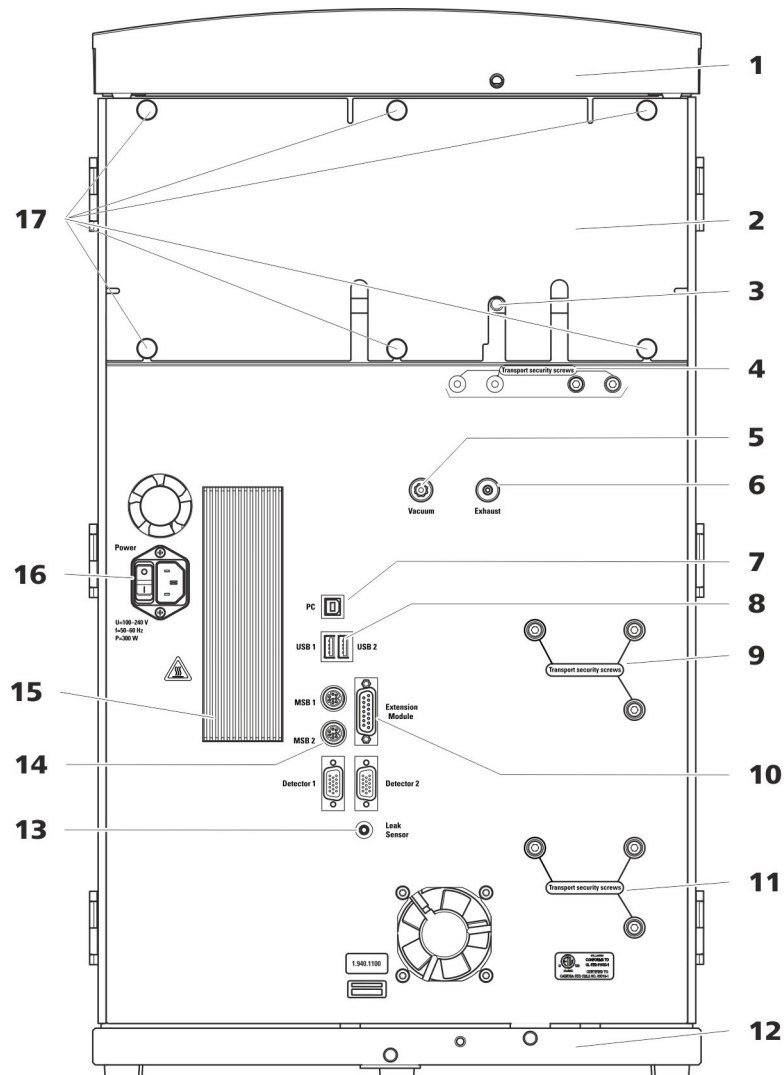

Figure 2 Rear

1 Bottle holder

Offers space for the eluent bottle(s) and additional accessories.

3 Drainage tubing connection

For connecting the drainage tubing, which guides escaped liquids away from the detector chamber.

2 Back panel

Removable. Enables access to the detector chamber.

4 Transport locking screws

For securing the vacuum pump(s) when transporting the instrument. Up to two vacuum pumps can be installed in an instrument. Only two transport locking screws are used if just one vacuum pump is installed.



<p>5 Vacuum connection For connecting an Extension Module that has a degasser but not its own vacuum pump. This connection has to be firmly sealed with a stopper when not in use.</p>	<p>6 Exhaust opening Labeled <i>Exhaust</i>. For extracting the air from the vacuum chamber.</p>
<p>7 PC connection socket For connecting the instrument to the computer with the USB cable (6.2151.020).</p>	<p>8 USB connection sockets Labeled <i>USB 1</i> and <i>USB 2</i>. For connecting USB devices.</p>
<p>9 Transport locking screws For securing the high-pressure pump (in the middle plug-in) when transporting the instrument.</p>	<p>10 Extension Module connection socket Labeled <i>Extension Module</i>. For connecting the cable (6.2156.060) used for connecting the instrument to the Extension Module.</p>
<p>11 Transport locking screws For securing the high-pressure pump (in the bottom plug-in) when transporting the instrument. These screws are only installed if a plug-in with a high-pressure pump is used in the bottom slot.</p>	<p>12 Base tray With leak sensor and leak sensor cable.</p>
<p>13 Leak sensor connection socket Labeled <i>Leak Sensor</i>. For connecting the leak sensor connection cable coiled up in the base tray.</p>	<p>14 MSB connection sockets Labeled <i>MSB 1</i> and <i>MSB 2</i>. For connecting MSB devices.</p>
<p>15 Cooler For cooling the power supply unit. May become hot!</p>	<p>16 Power socket Power socket for connecting the power cable and power switch for switching the instrument on and off.</p>
<p>17 Knurled screws For fastening the removable back panel.</p>	

2.3 Feed-throughs for capillaries and cables

Multiple openings are available for leading capillaries into the instrument and for leading capillaries and cables out of the instrument:

- Openings on the door (see *Figure 3, page 11*)
- Openings on the back panel
- Ducts between the instrument and the base tray as well as between the instrument and the bottle holder (see *Figure 5, page 13*)

Openings on the door



Figure 3 Feed-throughs on the door

1 Luer connector

For connecting a capillary from inside and for inserting a syringe (6.2816.020) from outside. For manual sample injection.

2 Opening for capillaries

For up to 3 capillaries.

An opening for up to 3 capillaries is located on the door of the instrument.

The two Luer connections above are not actually openings; the capillaries are fastened to the Luer connection from within using PEEK pressure screws. You can use a syringe to inject or draw out liquid from the outside.



Openings on the back panel

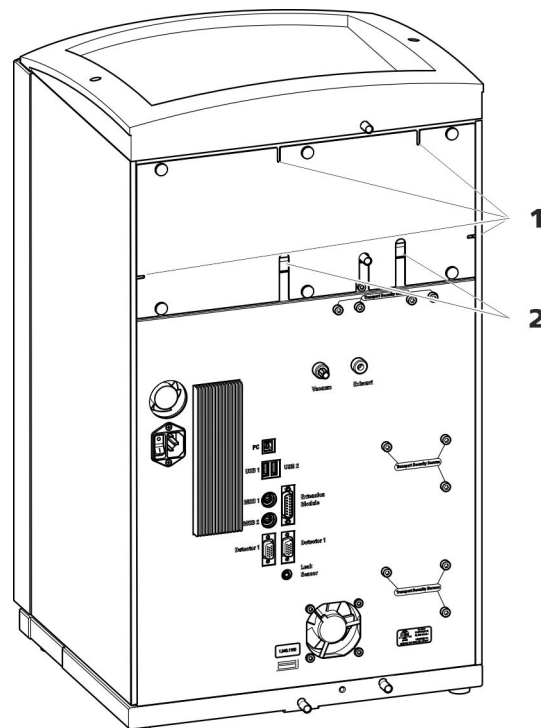

Figure 4 Openings for capillaries and cables

1 Openings for capillaries

2 Openings for cables

The removable back panel is outfitted with openings through which capillaries and cables can be lead out of the detector chamber.

Ducts for capillaries

There are ducts for capillaries between the instrument and base tray as well as between the instrument and the bottle holder. The capillaries can be fed to the front of the instrument from both sides of the instrument and from the front of the instrument to the back of the instrument.

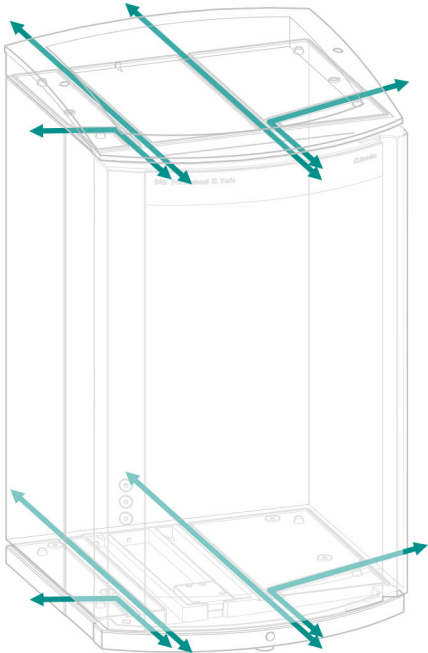

Figure 5 Ducts for capillaries



3 Installation

3.1 Setting up the instrument

3.1.1 Packaging

The instrument is supplied in protective packaging together with the separately packed accessories. Keep this packaging, as only this ensures safe transportation of the instrument.

3.1.2 Checks

Immediately after receipt, check whether the shipment has arrived complete and without damage by comparing it with the delivery note.

3.1.3 Location

The instrument has been developed for operation indoors and may not be used in explosive environments.

Place the instrument in a location of the laboratory which is suitable for operation, free of vibrations, protected from corrosive atmosphere, and contamination by chemicals.

The instrument should be protected against excessive temperature fluctuations and direct sunlight.

3.2 Capillary connections in the IC system

Generally speaking, capillary connections between two components of an IC system are made up of one connection capillary and two pressure screws used to connect the capillary to the respective components.

Pressure screws

Three types of pressure screws are used in the IC system:

Number	Designation	Use
6.2744.010 / 6.2744.014	Pressure screw	On the injection valve
6.2744.070	Pressure screw, short	High-pressure pump, purge valve, inline filter, pulsation absorber, separation columns
6.2744.090	Pressure screw, long	MCS, sample degasser, 10-port valve

Pressure screws are tightened and loosened by hand. A tool is not needed.

Also see: *PEEK pressure screws 1x1* video on the Internet <http://ic-help.metrohm.com>.

Connection capillaries

PEEK capillaries and PTFE capillaries are used in the IC system.

PEEK capillaries (polyetheretherketone)

PEEK capillaries are pressure-stable up to 400 bar (depending on the inner diameter), flexible, chemically inert and have an extremely smooth surface. They can be readily cut down to the desired length with the capillary cutter (6.2621.080).

Use:

- PEEK capillaries with an inner diameter of 0.25 mm (6.1831.010) for the entire high-pressure section.
- PEEK capillaries with an inner diameter of 0.5 mm (6.1831.180) for the sample path.

PTFE capillaries (poly(tetrafluoroethylene))

PTFE capillaries are transparent and enable visual tracing of the liquids to be pumped. They are chemically inert, flexible and temperature-resistant up to 80 °C. They can be readily cut down to the desired length with the capillary cutter (6.2621.080).

Use:

PTFE capillaries (6.1803.0x0) are used for the low-pressure section.

- PTFE capillaries with an inner diameter of 0.5 mm for sample processing and for the transfer of rinsing solutions (they are not necessarily included in the scope of delivery of the instrument).

Capillary connections



NOTE

Sprays of chemicals caused by capillaries slipping out

If you work with an increased system pressure (> 15 MPa), capillaries may slip out of the pressure screws. This can lead to sprays of chemicals.

To avoid this, we recommend

- degreasing the ends of the capillaries before installing them. Dampen a cloth with acetone and wipe off the ends of the capillaries before connecting them with the pressure screws.
- tightening the pressure screws firmly using a wrench (6.2739.000).

In order to achieve optimum analysis results, capillary connections in an IC system must be absolutely tight and free of dead volume. Dead volume



occurs if two capillary ends connected to each other do not fit exactly, thus allowing liquid to escape. There are two possible causes for this:

- The capillary ends do not have exactly flat edges.
- The two capillary ends do not completely meet.

One prerequisite for dead-volume-free capillary connection is that both capillary ends are cut exactly flat. Therefore we recommend cutting PEEK capillaries only with a capillary cutter (6.2621.080).

Also see: *Cutting capillaries* video on the Internet <http://ic-help.met-rohm.com>.

Creating dead-volume-free capillary connections

To create dead-volume-free capillary connections, proceed as follows:

- 1** Wipe off the end of the capillary with a cloth dampened with acetone.
- 2** Slide the pressure screw over the capillary. Ensure that the capillary protrudes 1 to 2 mm from the tip of the pressure screw.
- 3** Push the capillary into the connection or coupling as far as it will go and hold it there.
- 4** Only then start turning the pressure screw. Hold the capillary in the stop position while turning it shut.

Colored sleeves for PEEK capillaries

The enclosed set of varicolored sleeves for PEEK capillaries (6.2251.000) serves to easily differentiate the various flows of liquid in the system through color coding. Each capillary conveying a given liquid (e.g. eluent) can be marked with sleeves of the same color.

- 1** Slide a colored sleeve of a selected color over a capillary and move it to an easily visible position.
- 2** Heat the colored sleeve, e.g. with a hairdryer.

The colored sleeve shrinks and adapts to the shape of the capillary.



NOTE

In order to arrange capillaries more clearly, they can be bundled with the spiral band (6.1815.010).

3.3 Removing the handle

The instrument is equipped with a handle in order to make it easier to transport. The handle can be removed once the instrument is in place in the lab.

Accessories

You do not need any accessories for the following work steps.

Removing the handle

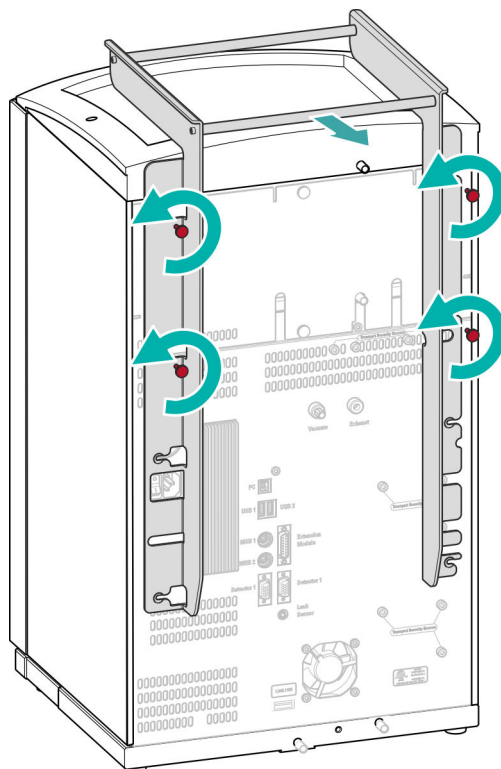

1 Removing the handle

- Unscrew the four knurled screws.
- Remove the handle.



3.4 Removing transport locking screws

To avoid damage to the drives for the high-pressure pump and the vacuum pump during transport, the pumps are secured with transport locking screws. These are located at the rear of the instrument and labeled with **Transport security screws**.

Remove these transport locking screws before the initial start-up.

Accessories

For this step you need:

- 4 mm hex key (6.2621.030)

Removing the transport locking screws

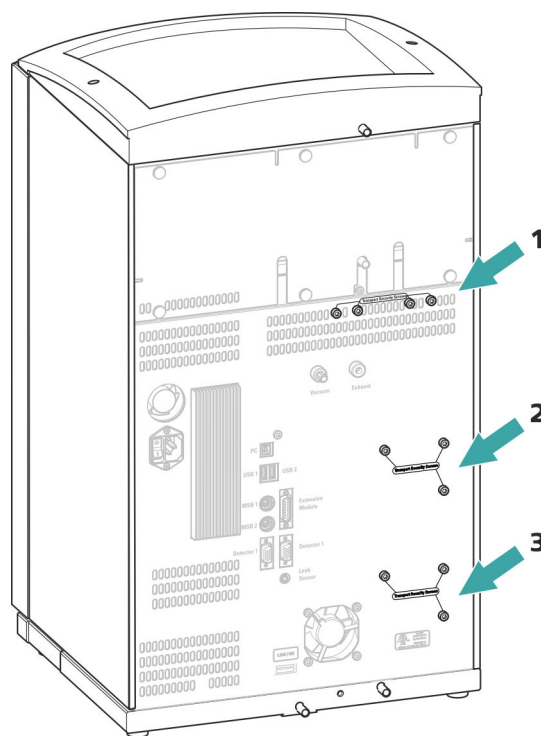

Figure 6 Removing the transport locking screws

1 Transport locking screws
For the vacuum pump.

2 Transport locking screws
For the high-pressure pump.

3 Transport locking screws
For an additional high-pressure pump in the bottom drawer.

- 1** Remove all of the transport locking screws with the hex key.

Store the transport locking screws in a safe place. Reinsert the transport locking screws each time you transport the instrument a significant distance.



CAUTION

The pumps may be damaged if you transport the instrument without inserting the transport locking screws.

3.5 Connecting the drainage tubing and leak sensor

The leak sensor detects leaking liquid that collects in the instrument's base tray. Liquid that leaks in the bottle holder or in the detector chamber is conveyed to the base tray using drainage tubing and is detected there.

If the leak sensor detects a leak in the IC system, the IC instrument is switched off. The software displays a warning.

The leak sensor functions properly only if the following preconditions are met:

- The drainage tubing is connected.
- The leak sensor connection cable is inserted into the leak sensor connection socket.
- The 940 Professional IC Vario is switched on.
- The leak sensor is switched to **active** in the software.

3.5.1 Installing the drainage tubing

Liquid that leaks in the bottle holder or detector chamber flows to the rear of the instrument. Openings on the bottle holder and in the detector chamber allow the liquid to drain. The drainage tubing has to be mounted at these openings. This drainage tubing guides the leaking liquid to the base tray where the leak sensor is located.

Accessories

For this step you need the following parts from the accessory kit: Vario/Flex Basic (6.5000.000):

- 2 × silicone tubing (6.1816.020)
- Y connector (6.1807.010)

You also need scissors.



Connecting the drainage tubing

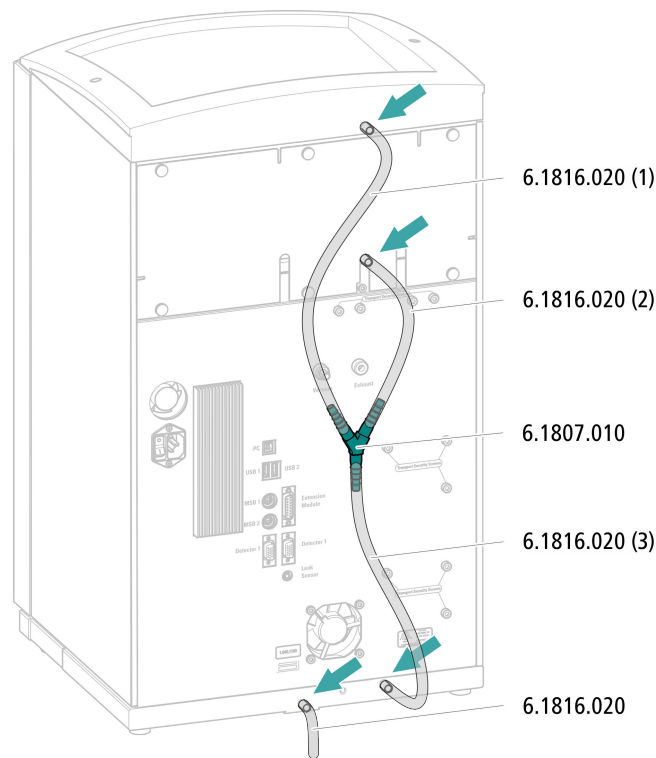

- 1** Cut a piece of silicone tubing into three pieces using scissors: 2 × approx. 40 cm and 1 × 20 cm.
- 2** Attach one end of the 40 cm long piece to the drainage tubing connection on the bottle holder.
- 3** Attach one end of the 20 cm long piece to the drainage tubing connection on the detector chamber.
- 4** Attach each of the loose ends of both pieces of silicone tubing to one end of the Y connector.
- 5** Attach one end of the second 40 cm long piece to the third end of the Y connector.
Attach the loose end to the right-side drainage tubing connection on the base tray.
- 6** Attach one end of the second piece of silicone tubing to the left-side drainage tubing connection on the base tray.

Route the loose end into a waste container.

3.5.2 Connecting the leak sensor

Plugging in the leak sensor connection cable

The leak sensor connection cable is coiled up in the base tray.

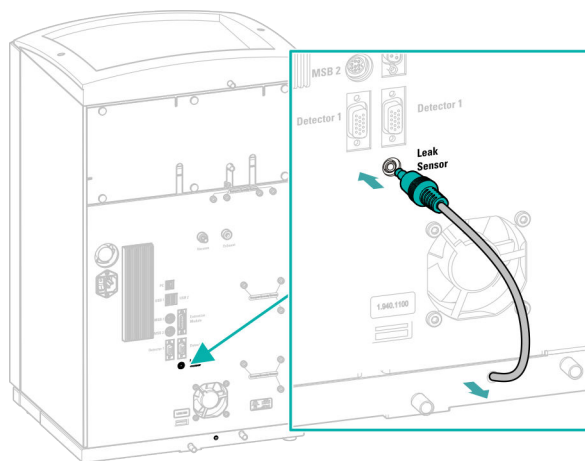

- 1 Pull the leak sensor connection cable out of the base tray as far as needed.
- 2 Plug the plug for the leak sensor connection cable into the leak sensor connection socket (labeled **Leak Sensor**).

3.6 Column thermostat

The column thermostat ensures that the flow of eluent and the separation column(s) are at a constant temperature. It is firmly sealed by the instrument's smaller door and is well insulated. The capillaries are fed through small openings on the inner front edge, so that they do not get pinched when the door is closed.

The column thermostat is completely connected. No installation work is required.



3.7 Connecting the eluent bottle

The eluent is aspirated out of the eluent bottle via the eluent aspiration tubing. The eluent aspiration tubing is installed on the entry to the eluent degasser.

The tubing must be fed out of the instrument through a suitable opening (see "Openings on the back panel", page 12) before the loose end can be connected to the eluent bottle.

Accessories

For this step, you need the following accessories:

These parts are part of the accessory kit *Vario/Flex ONE* (6.5000.010).

- Eluent bottle (6.1608.070)
- The *eluent bottle cap GL 45* accessory set (6.1602.160)
This accessory set contains the bottle cap, an M6 tubing nipple, an M8 tubing nipple, two O-rings and an M6 and M8 threaded stopper.
- The *tubing adapter for aspiration filter* accessory set (6.2744.210)
This accessory set contains a filter holder, a clamping screw and tubing weighting.
- An aspiration filter (6.2821.090)
- The adsorber tube (6.1609.000)
- The SGJ clip (6.2023.020)

Connecting the eluent aspiration tubing

1 Installing the eluent bottle cap (6.1602.160)

- Start by pushing the M8 tubing nipple onto the loose end of the eluent aspiration tubing, followed by the O-ring.
- Push the loose end of the eluent aspiration tubing through the M8 opening of the bottle cap and screw it on for the time being.

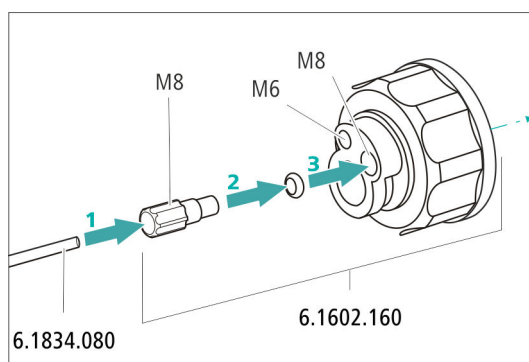

Figure 7 Installing the eluent bottle cap

2 Mounting the tubing adapter

Install the parts of the *tubing adapter for aspiration filter* (6.2744.210) accessory set:

- Start by pushing the tubing weighting onto the loose end of the eluent aspiration tubing.
- Then push the clamping screw onto the loose end of the eluent aspiration tubing.
- Lastly, push the filter holder onto the loose end of the eluent aspiration tubing and screw it onto the tubing nipple.
The end of the tubing should extend approximately 1 cm.

3 Pre-rinsing the aspiration filter



NOTE

Always wear gloves when handling the aspiration filter.

In order to avoid air bubbles after the installation of the aspiration filter, we recommend pre-rinsing the aspiration filter with water or eluent.

For pre-rinsing, you will need the holder for the eluent aspiration filter (6.2744.360), a syringe and the purge needle (6.2816.040).

This procedure can also be found in the video "Inserting a new aspiration filter" at the following link: ic-help.metrohm.com

4 Mounting aspiration filter



NOTE

Always wear gloves when handling the aspiration filter.

- Place the loose end of the eluent aspiration tubing into the aspiration filter.
The end of the tubing should reach approximately to the center of the aspiration filter.
- Tighten the aspiration filter to the filter holder.

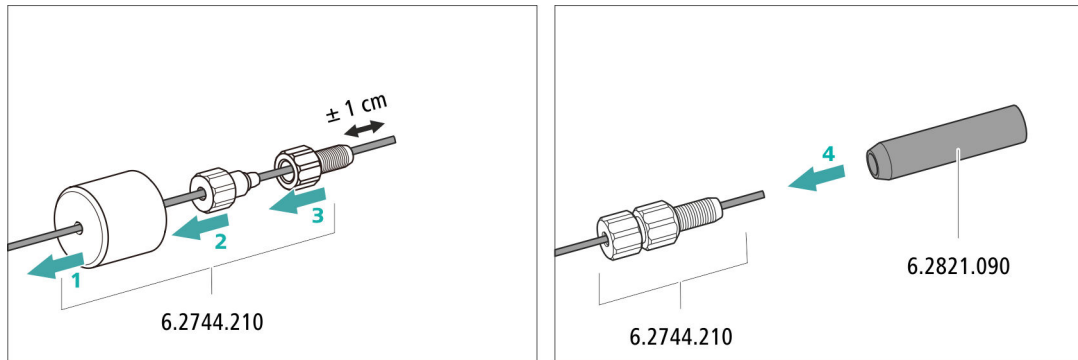
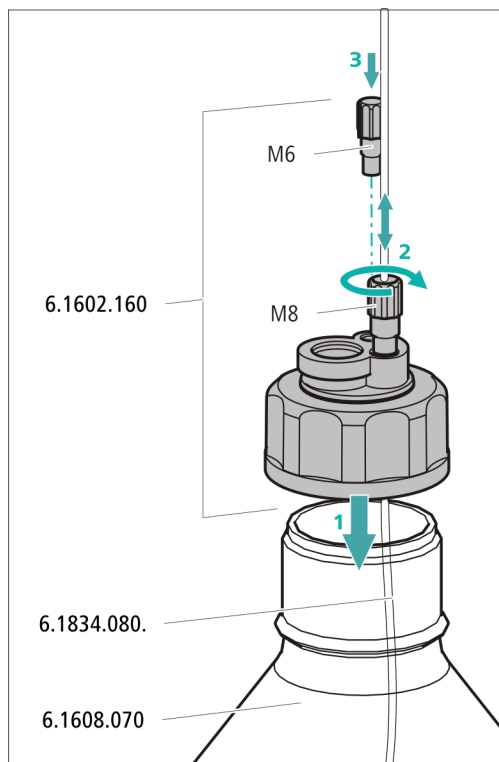

Figure 8 Installing tubing weighting and aspiration filter

5 Installing the eluent bottle cap on the eluent bottle

- Insert the eluent aspiration tubing into the eluent bottle (6.1608.070).
- Tighten the bottle cap on the eluent bottle.
- Adjust the length of the eluent aspiration tubing so that the aspiration filter is at the bottom of the eluent bottle. Then fix it in place using the M8 tubing nipple.
- Seal the M6 opening on the bottle cap with the M6 threaded stopper from the accessory set.



6 Mounting the adsorber tube



NOTE

Depending on the eluent used, the adsorber tube (6.1609.000) must be filled differently:

- For alkaline eluents or eluents with a low buffer capacity: first a little cotton, then with CO₂ adsorber material.
 - For all other eluents: only with cotton.
- Remove the plastic cover from the large opening of the adsorber tube. Fill the adsorber tube and close it again using the plastic cover.
 - Insert the adsorber tube into the bottle cap's large opening. Fasten it to the bottle cap using the SGJ clip (6.2023.020).

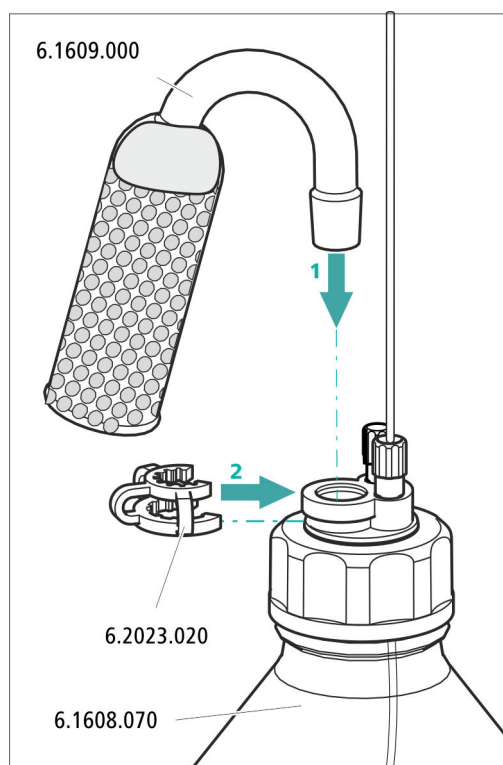



3.8 Connecting the eluent degasser

The high-pressure pump cannot generate uniform flow if the eluent contains small gas bubbles or dissolved gas. As a result, the baseline cannot be stabilized correctly. In order to achieve good measurement results, the eluent has to be degassed before it goes into the high-pressure pump.

The eluent degasser is completely connected. No installation work is required.

3.9 Installing the high-pressure pump

The intelligent and low-pulsation high-pressure pump pumps the eluent through the system. It is equipped with a chip where its technical specifications and "life history" (operating hours, service data, etc.) are saved.

The high-pressure pump consists of:

- The pump head, which pumps the eluent through the system.
- The purge valve used for bleeding the pump head.

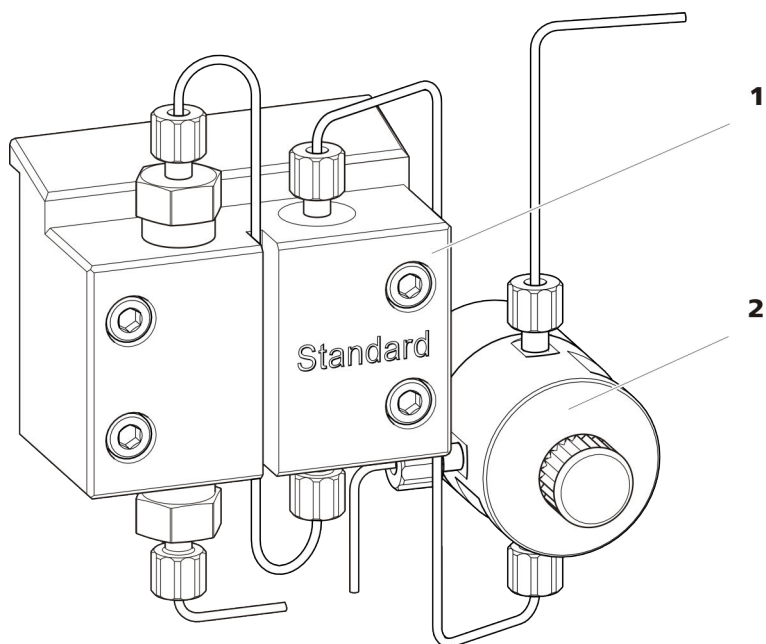

Figure 9 High-pressure pump with purge valve

1 Pump head

2 Purge valve

The high-pressure pump is completely connected. No installation work is required.

3.10 Installing an inline filter

Inline filters protect the separation column reliably from potential contamination from the eluent. The small filter pads with 2 µm pore size can be replaced quickly and easily. They remove particles from the solutions.

An inline filter (6.2821.120) is installed between the purge valve and the pulsation absorber as protection against particles.

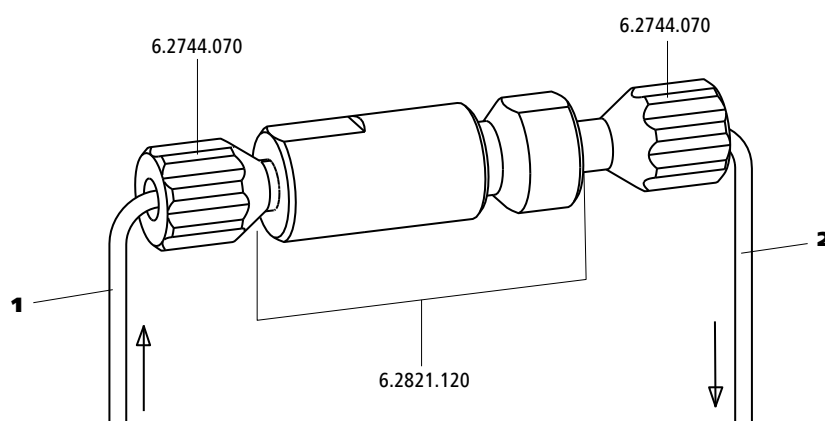

Figure 10 Inline filter

1 Inlet capillary

Connected to the purge valve.

2 Outlet capillary

Connected to the pulsation absorber.

The inline filter is completely connected. No installation work is required.

3.11 Installing the pulsation absorber

The pulsation absorber is installed between the high-pressure pump and the injection valve. It protects the separation column from damage caused by pressure fluctuations, e.g. when the injection valve is switched, and reduces interfering pulsations during highly sensitive measurements.

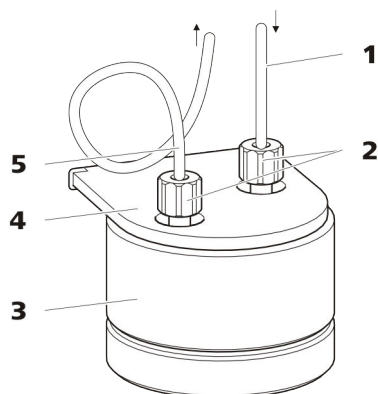

Figure 11 Pulsation absorber

1	Connection capillary Connection to inline filter.	2	PEEK pressure screws, short (6.2744.070)
3	Pulsation absorber (6.2620.150)	4	Holder for pulsation absorber
5	Connection capillary Connection to injection valve.		

The pulsation absorber is completely connected. No installation work is required.

3.12 Injection valve

The injection valve connects the eluent path to the sample path. By a quick and precise switching of the valve a defined quantity of sample solution is injected and flushed to the separation column with the eluent.

The quantity of sample solution injected is determined by:

- the volume of the sample loop or
- by an 800 Dosino when the Metrohm intelligent Partial Loop Injection Technique (MiPT), the Metrohm intelligent Pick-up Injection Technique (MiPuT) or the Metrohm Inline Preconcentration (MiPCT, MiPCT-ME) is used.

The choice of sample loop depends on the application. The following sample loops are normally used:

Table 1 Which sample loop do I need?

Application	Sample loop
Cation determination	20 μ L
Anion determination with suppression	20 μ L
Anion determination without suppression	100 μ L
MiPT, MiPuT	250 μ L

Application	Sample loop
MiPCT, MiPCT-ME	Preconcentration column

The injection valve is completely connected. No installation work is required.

Optional: Exchanging the sample loop

The sample loop can be replaced to match the application (see Table 1, page 28).



NOTE

Only use PEEK pressure screws (6.2744.010) to connect capillaries and the sample loop to the injection valve.

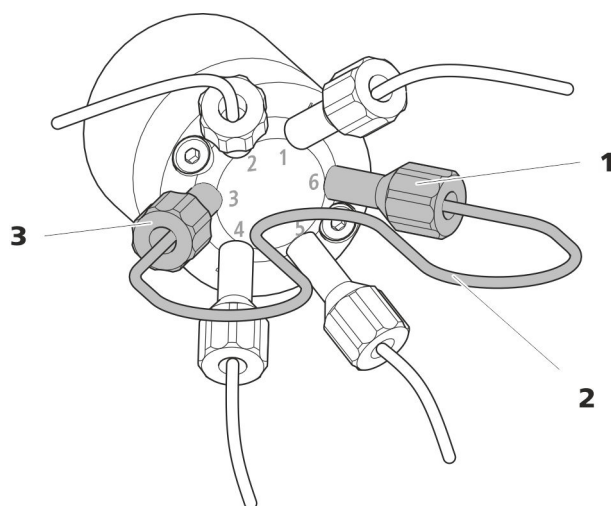

Figure 12 Exchanging the sample loop

1 Pressure screw
Fastened to Port 6.

2 Sample loop

3 Pressure screw
Fastened to Port 3.



Exchanging the sample loop



NOTE

Observe a dead-volume-free installation of the sample loop (see "Creating dead-volume-free capillary connections", page 16).

1 Removing the existing sample loop

- Loosen the pressure screws (6.2744.010) at Port 3 and Port 6.
- Remove the sample loop.

2 Installing a new sample loop

- Fasten one end of the sample loop to Port 3 using a PEEK pressure screw (6.2744.010).
- Use the second PEEK pressure screw (6.2744.010) to fasten the other end of the sample loop to Port 6.

3.13 Installing the conductivity detector

The 940 Professional IC Vario provides enough space for two detectors and additional accessories in the detector chamber. The detectors are available as separate devices and are supplied with separate manuals.

Placing the detector in the instrument

Follow the instructions in the chapter *Inserting the detector* in the manual for the detector.

Connecting the detector to the eluent path



NOTE

The separation column is not inserted into the instrument until it is being started up for the first time. Until then, the detector inlet capillary has to be connected directly to the column inlet capillary using a coupling (6.2744.040).

Accessories

For this step, you need the following accessories:

- Coupling (6.2744.040)
- 2 × pressure screw (6.2744.010)

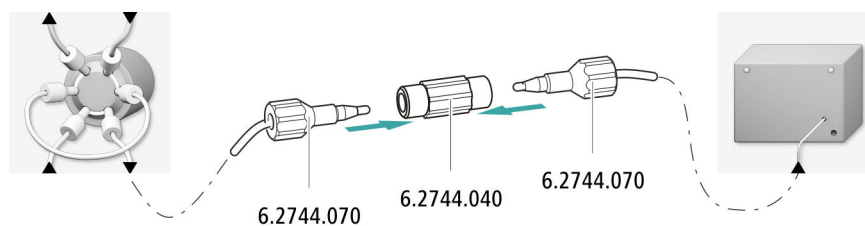

- 1 Connect the column inlet capillary and the detector inlet capillary to one another using a coupling (6.2744.040) and two short pressure screws (6.2744.070).

3.14 Installing the amperometric detector

The 940 Professional IC Vario provides enough space for two detectors and additional accessories in the detector chamber. The detectors are available as separate devices and are supplied with separate manuals.

Placing the detector in the instrument

Follow the instructions in the chapter *Inserting the detector* in the manual for the detector.

3.15 Connecting the sample degasser (optional)

Gas bubbles in the sample lead to poor reproducibility, as the amount of sample in the sample loop is not always the same. Therefore, we recommend degassing samples that contain gas before injection.



NOTE

The sample degasser does not have to be connected. We recommend only using the sample degasser if the application requires it.

The rinsing time increases by at least two minutes when the sample degasser is connected.

Accessories

For this step, you need the following accessories:

- 2 × pressure screw, long (6.2744.090)
- PTFE capillary (6.1803.040)



Connecting the sample degasser

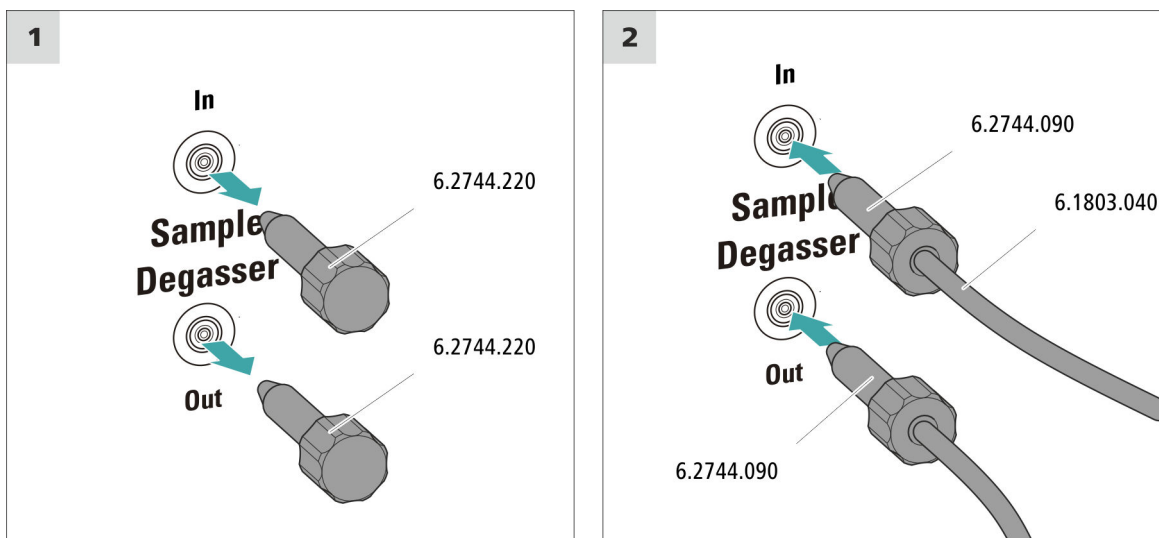

CAUTION

If the sample degasser is not used, the inlet and outlet **must** be sealed with threaded stoppers (6.2744.220).

1 Removing the threaded stoppers

Remove and keep the threaded stoppers (6.2744.220) from the inlet and outlet of the sample degasser.

2 Connecting the outlet capillary

- Push a long pressure screw over the loose end of the capillary connected to Port 1 of the injection valve.
- Tighten the pressure screw to the outlet of the sample degasser (labeled **Out**).

Try to ensure the shortest possible connections (shorten the capillary if necessary).

3 Connecting the inlet capillary

- Push a long pressure screw over one end of the PTFE capillary (6.1803.040) and tighten the pressure screw to the inlet of the sample degasser (labeled **In**).

- Guide the other end of the PTFE capillary (6.1803.040) out of the instrument through a capillary feed-through and connect it to the Sample Processor, if applicable.
Try to ensure the shortest possible connections (shorten the capillary if necessary).

3.16 Installing the high-pressure gradient module

The outlets of the two high-pressure pumps are connected to the injection valve's eluent inlet after the pulsation absorber using the mixing coil for high-pressure gradients (6.2758.000).

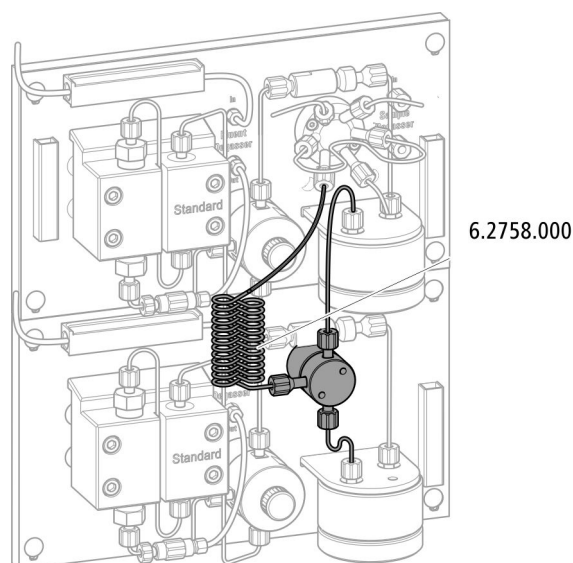

Connect the two pieces of eluent aspiration tubing to an eluent bottle (see Chapter 3.7, page 22).

3.17 Connecting the instrument to a computer



NOTE

If the instrument is connected to the computer, then it must be switched off.

Accessories

For this step, you need the following accessories:

- USB connecting cable (6.2151.020)



Connecting the USB cable

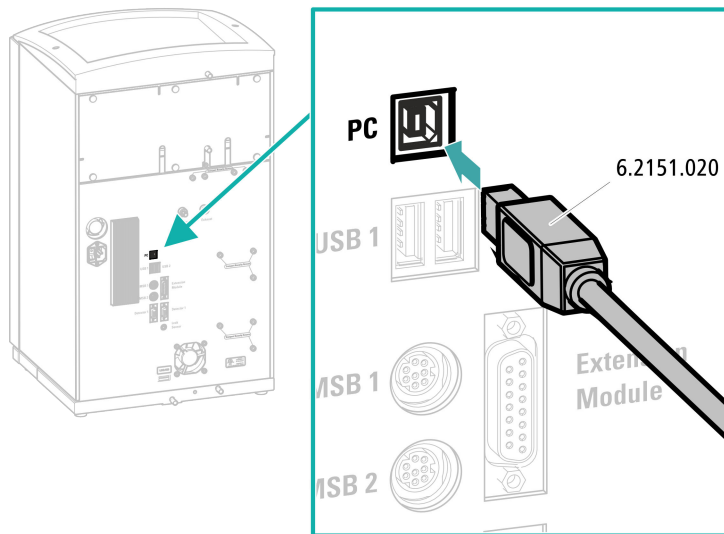

- 1 Insert the USB cable into the computer connection socket on the rear of the instrument labeled *PC*.
- 2 Insert the other end into a USB port on the computer.

3.18 Connecting the instrument to the power grid



WARNING

Electric shock from electrical potential

Risk of injury by touching live components or through moisture on live parts.

- Never open the housing of the instrument while the power cord is still connected.
- Protect live parts (e.g. power supply unit, power cord, connecting socket) from moisture.
- Unplug the power plug immediately if you suspect that moisture has gotten inside the instrument.
- Only personnel who have been issued Metrohm qualification may perform service and repair work on electrical and electronic parts.

Accessories

Connecting the power cord

Power cord, three-core with IEC 60320 instrument plug type C13. Conductor cross-section 1 mm² / 18 AWG. Power plug according to customer requirement (6.2122.XX0).

Do not use a not permitted power cord.

1 Plugging in the power cord

- Plug the power cord into the instrument's power socket.
- Connect the power cord to the power grid.

The power cord is three-core and provided with a plug with grounding. If another plug has to be mounted, connect the yellow/green conductor (IEC standard) to the protective ground (protection class I).

3.19 Initial start-up

Even before the guard column and separation column are installed, the entire system must be completely rinsed with eluent for the first time.

Rinsing the IC system**CAUTION**

The separation column and the guard column are not permitted to be installed at the time of the initial start-up.

Make sure that a coupling (6.2744.040) is being used instead of the columns.

1 Preparing the software

- Start the **MagIC Net** computer program.
- Open the **Equilibration** tab in MagIC Net: **Workplace ▶ Run ▶ Equilibration**.
- Import (or create) a suitable method.
Also see: *MagIC Net Tutorial* and online help.

2 Preparing the instrument

- Ensure that the eluent aspiration tubing is immersed in the eluent and that there is enough eluent in the eluent bottle.
- Switch on the instrument.



MagIC Net detects the instrument and all of its modules.

3 Starting equilibration

- Start the equilibration in MagIC Net: **Workplace ▶ Run ▶ Equilibration ▶ Start HW.**

4 Deaerating the high-pressure pump

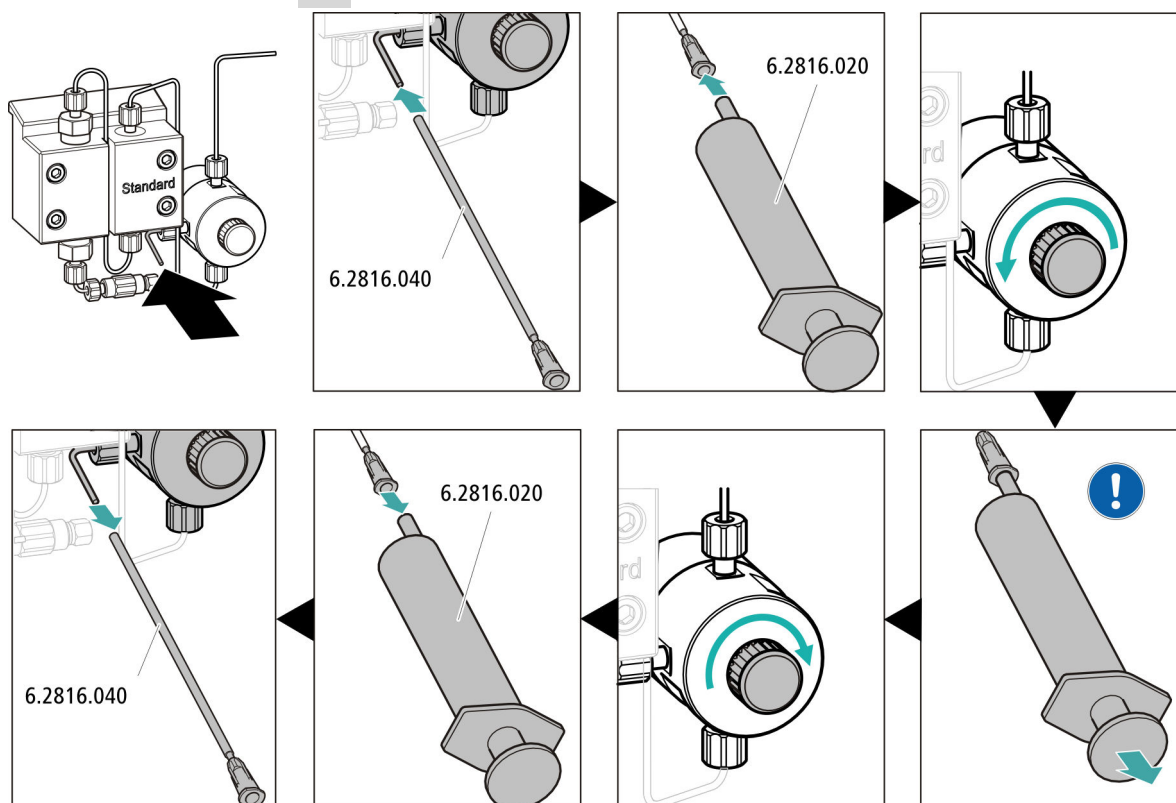

- Push the end of the purge needle (6.2816.040) over the end of the purge capillary on the purge valve.
- Insert the syringe (6.2816.020) in the Luer connector of the purge needle.
- Open the purge valve using the rotary knob (approx. $\frac{1}{2}$ turn).
- Switch on the high-pressure pump in MagIC Net.
- Use the syringe to aspirate eluent until there are no more air bubbles in the eluent aspiration tubing.
- Switch off the high-pressure pump in MagIC Net.
- Seal the purge valve using the rotary knob.
- Remove the syringe from the purge needle.
- Pull the purge needle out of the purge capillary.

5 Rinsing the instrument without columns

- Rinse the instrument (without columns) with eluent for 10 minutes.

3.20 Connecting and rinsing the guard column

Guard columns protect separation columns and significantly increase their service life. The guard columns available from Metrohm are either actual guard columns or guard column cartridges used together with a cartridge holder. The process of installing a guard column cartridge into the corresponding holder is described in the guard column leaflet.



NOTE

Metrohm recommends always working with guard columns. They protect the separation columns and can be replaced regularly as needed.



NOTE

Information regarding which guard column is suitable for your separation column can be found in the **Metrohm Column Program** (which is available from your Metrohm representative), the leaflet provided along with your separation column or the product information about the separation column at <http://www.metrohm.com> (Ion Chromatography product area), or it can be obtained directly from your representative.



CAUTION

New guard columns are filled with a solution and sealed with stoppers or caps on both sides.

Before inserting the guard column, ensure that this solution can be mixed with the eluent being used (follow the information provided by the manufacturer).

**NOTE**

The guard column may not be connected until after the instrument has already been put into operation once (see *Chapter 3.19, page 35*). The guard column and the separation column have to be replaced by a coupling (6.2744.040) until then.

Accessories

For this step, you need the following accessories:

- Guard column (suitable for separation column)

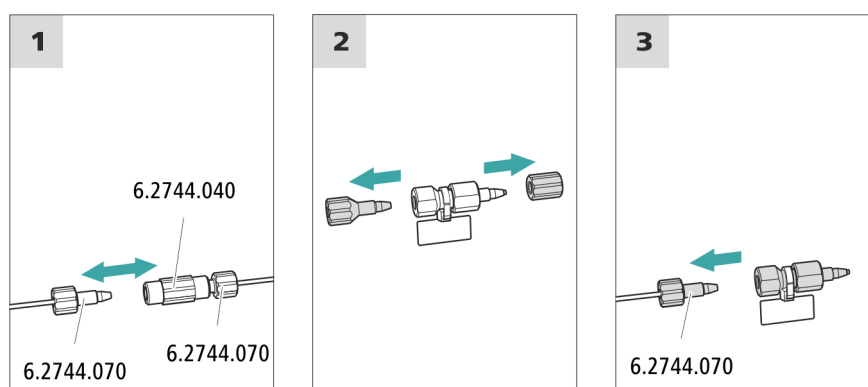
Connecting the guard column**1 Removing the coupling**

Remove the coupling (6.2744.040) installed between the column inlet capillary and the column outlet capillary for the initial start-up.

2 Preparing the guard column

- Remove the stoppers or the stopper and the sealing cap from the guard column.

3 Connecting the guard column**CAUTION**

When inserting the guard column, ensure that it is inserted correctly based on the marked flow direction (if specified).

- Fasten the inlet of the guard column to the column inlet capillary using a short pressure screw (6.2744.070).

- If the guard column is connected to the separation column using a connection capillary, fasten this connection capillary to the guard column outlet with a pressure screw.

Rinsing the guard column

1 Rinsing the guard column

- Place a beaker under the guard column's outlet.
- Start manual control in MagIC Net and select the high-pressure pump: **Manual ▶ Manual control ▶ Pump**
 - **Flow: in accordance with column leaflet**
 - **On**
- Rinse the guard column with eluent for approx. 5 minutes.
- Stop the high-pressure pump in the manual control in MagIC Net again: **Off**.

3.21 Connecting the separation column

The smart separation column (iColumn) is the heart of ion chromatographic analysis. It separates the different components according to their interactions with the column. Metrohm separation columns are equipped with a chip where their technical specifications and history (start-up, operating hours, injections etc) are stored.



NOTE

Information regarding which separation column is suitable for your application can be found in the **Metrohm Column Program**, the product information for the separation column or it can be obtained through your representative.

You can find product information for your separation column at <http://www.metrohm.com> in the Ion Chromatography product area.

A test chromatogram and a leaflet accompanies every column. Detailed information on special IC applications can be found in the corresponding "**Application Bulletins**" or "**Application Notes**". You can find these online at <http://www.metrohm.com> in the Applications area or request them from your responsible Metrohm representative free of charge.

**CAUTION**

New separation columns are filled with a solution and sealed with stoppers on both sides. Before inserting the column, ensure that this solution can be mixed with the eluent being used (follow the information provided by the manufacturer).

**NOTE**

Connect the separation column only after the initial start-up of the instrument. Until that point, insert a coupling (6.2744.040) instead of the guard column and separation column.

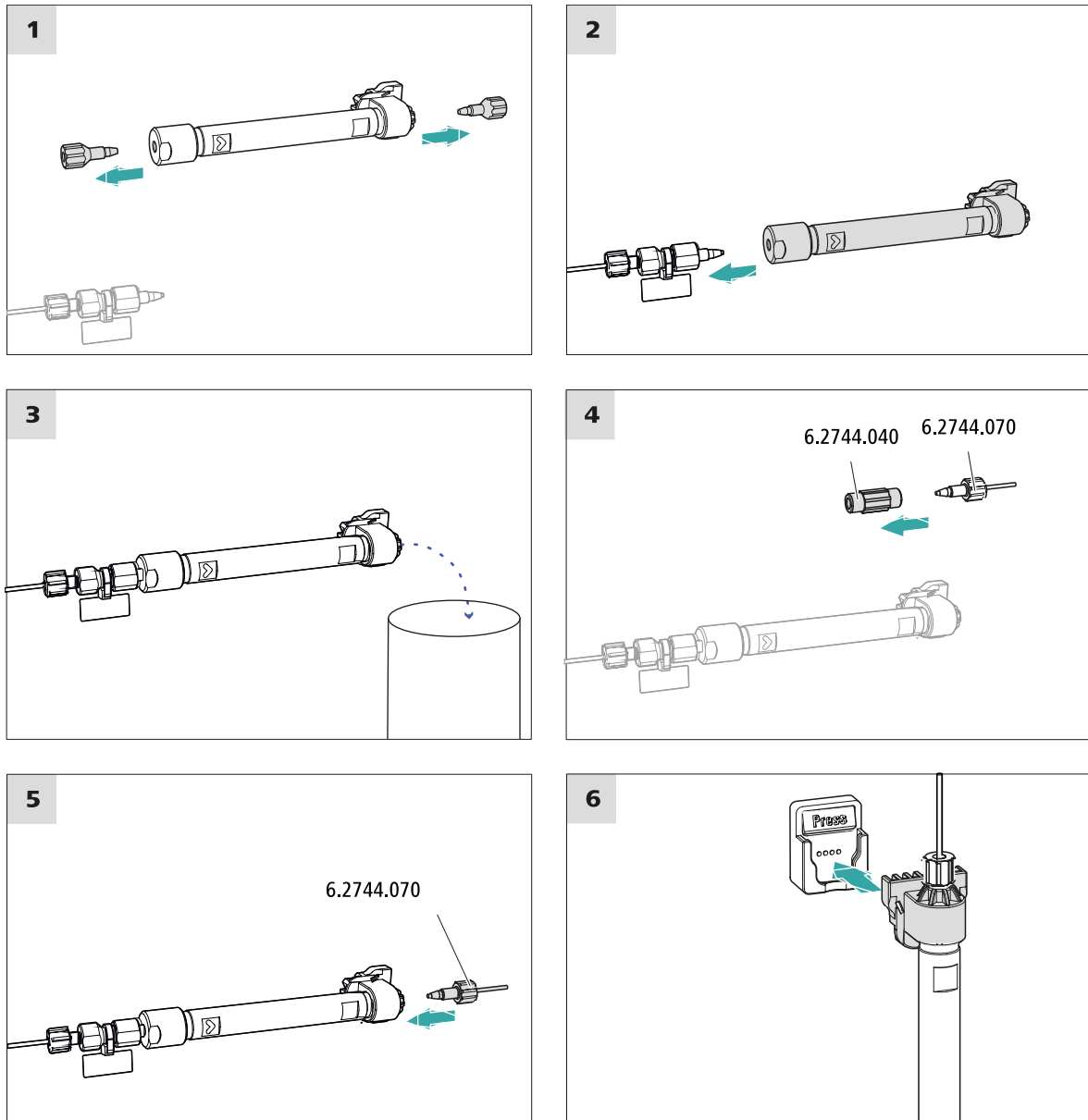

Connecting the separation column

1 Removing the stoppers

- Remove the stoppers from the separation column.



2 Installing the inlet of the separation column



CAUTION

When inserting the column, ensure that it is inserted correctly based on the marked flow direction.

There are three options:

- Attach the column inlet directly onto the guard column or,
- if the guard column is connected to the separation column using a connection capillary: Connect the column inlet to the guard column outlet capillary using a PEEK pressure screw (6.2744.070) or,
- if no guard column is used (not recommended): Connect the column inlet capillary to the inlet of the separation column using a short pressure screw (6.2744.070).

3 Rinsing the separation column

- Place a beaker under the outlet of the separation column.
- Start manual control in MagIC Net and select the high-pressure pump: **Manual ▶ Manual control ▶ Pump**
 - **Flow:** Increase gradually up to the flow rate recommended in the column leaflet.
 - **On**
- Rinse the separation column with eluent for approx. 10 minutes.
- Stop the high-pressure pump in the manual control in MagIC Net again: **Off**.

4 Removing the coupling

- Remove the coupling (6.2744.040) from the column outlet capillary.

5 Installing the outlet of the separation column

- Fasten the column outlet capillary to the column outlet using a short PEEK pressure screw (6.2744.070).

6 Inserting the separation column

- Insert the separation column with the chip into the column holder until you hear it snap in place.

The separation column is now detected by MagIC Net.

3.22 Conditioning

In the following cases, the system must be conditioned with eluent until a stable baseline has been reached:

- After installation
- After each time the instrument is switched on
- After each eluent change



NOTE

The conditioning time can lengthen considerably if the composition of the eluent is modified.

Conditioning the system

1 Preparing the software



CAUTION

Ensure that the configured flow rate is not higher than the flow rate permitted for the corresponding column (refer to the column leaflet and chip data record).

- Start the **MagIC Net** computer program.
- Open the **Equilibration** tab in MagIC Net: **Workplace ▶ Run ▶ Equilibration**.
- Select (or create) a suitable method.
Also see: *MagIC Net Tutorial* and online help.

2 Preparing the instrument

- Ensure that the column is inserted correctly in accordance with the flow direction marked on the sticker (arrow has to point in the direction of flow).
- Ensure that the eluent aspiration tubing is immersed in the eluent and that there is enough eluent in the eluent bottle.

3 Starting equilibration

- Start the equilibration in MagIC Net: **Workplace ▶ Run ▶ Equilibration ▶ Start HW**.



- Visually inspect whether all capillaries and their connections from the high-pressure pump to the detector are leak-tight. If eluent is leaking out anywhere, tighten the corresponding pressure screw further, or loosen the pressure screw, check the end of the capillary and shorten it using the capillary cutter if necessary and retighten the pressure screw.

4 Conditioning the system

Continue rinsing the system with eluent until the desired stability level for the baseline has been attained .

The instrument is now ready for measuring samples.

4 Operation

The 940 Professional IC Vario ONE/HPG is operated solely using the MagIC Net software. You can find information on operating the software in the tutorial for MagIC Net or in the online help.

5.1.4 Shutting down and recommissioning

If the instrument is no longer used for a prolonged period, remove the guard column and the separation column. Rinse the IC system until it is salt-free with a mixture of methanol and ultrapure water (1:4). This prevents eluent salts from crystallizing and then causing damage. This prevents eluent salts from crystallizing and then causing consequential damage.

Rinsing the IC system to be free of salts

- 1** In the software, stop the hardware and wait until the pressure in the high-pressure pump has been released.
- 2** Remove the guard column and the separation column from the eluent path. Connect the connection capillaries directly with each other using a coupling (6.2744.040).
- 3** Rinse the IC system for 15 minutes with methanol/ultrapure water mixture (1:4).
- 4** Optional: Only if the IC system is equipped with a suppressor.
In the software, switch the Metrohm Suppressor Module (MSM) twice during the rinsing process at five-minute intervals in each case (STEP command).
- 5** Optional: Only if the IC system is equipped with a suppressor and a peristaltic pump.
Rinse the pump tubings used for the peristaltic pump with water for 15 minutes at level 1. Finish by releasing the contact pressure at the peristaltic pump.

Putting the IC system back into operation

- 1** Check that a coupling (6.2744.040) is installed in place of the guard column and the separation column.
- 2** Rinse the IC system with freshly prepared eluent for 15 minutes.
- 3** Remove the coupling and install the guard column and the separation column (see Chapter 3.20, page 37 and Chapter 3.21, page 39).



5.2 Capillary connections

All capillary connections between the injection valve, the separation column and the detector must be as short as possible, have a low dead volume and be completely leak-tight.

The PEEK capillary downstream of the detector must be free of blockages.

Use only PEEK capillaries with an inner diameter of 0.25 mm between the high-pressure pump and the detector (high-pressure section).

5.3 Servicing the door



CAUTION

The door is made of PMMA (poly(methyl methacrylate)). It must never be cleaned with abrasive media or solvents.



CAUTION

Never hold the instrument by the door when lifting it. Only hold the instrument by the housing.

5.4 Column thermostat – Replacing the capillaries

There are two preheating grooves on both of the column thermostat's side walls, where the column inlet capillary has already been inserted and fastened in place with a holder plate.

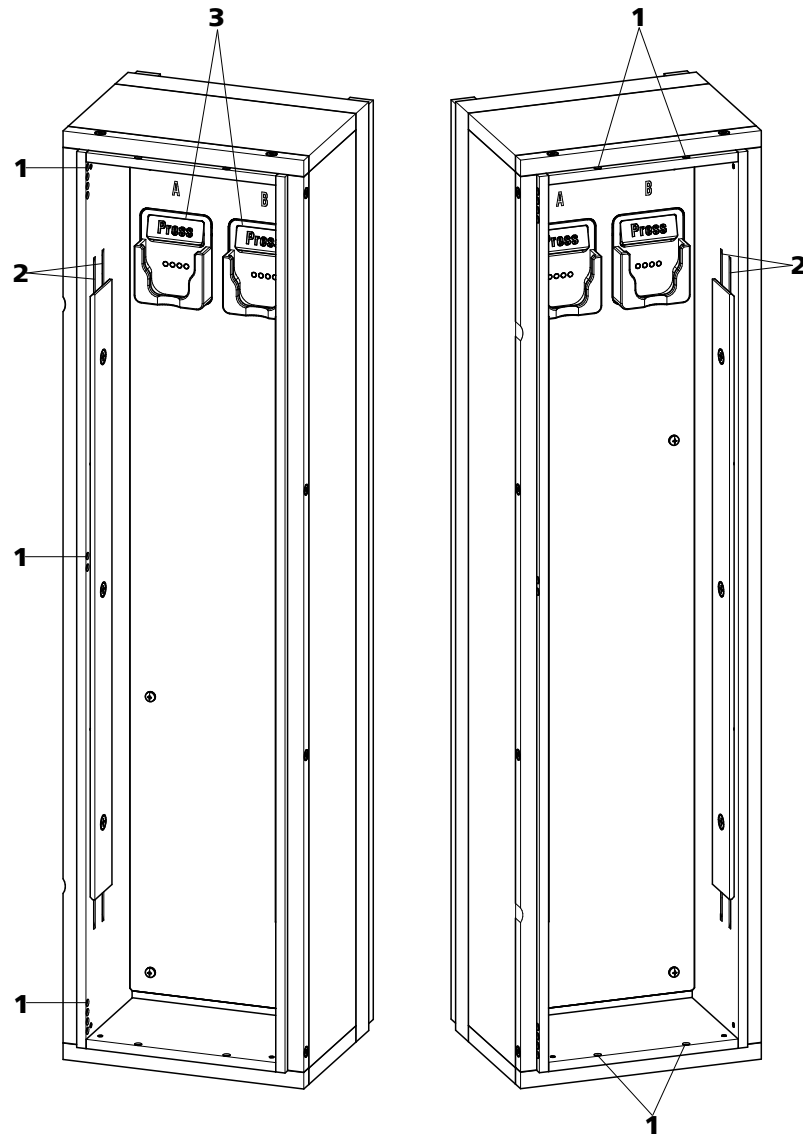

Figure 13 Column thermostat

1 Openings

For feeding capillaries into and out of the instrument.

3 Column holder

With column recognition. For fastening the column.

2 Preheating grooves

For regulating the temperature of the eluent.



Replacing the preheating capillaries

In order to make threading the column inlet capillary into the column thermostat's preheating grooves easier, we recommend loosening the screws for the holder plate a little, but not removing them all the way.

- 1** Guide the column inlet capillary into the column thermostat via a suitable opening (13-1).
- 2** Push the column inlet capillary into the outer preheating groove (13-2) from the bottom. Continue pushing it through under the holder plate until it comes back out the top.
- 3** Carefully bend the column inlet capillary downward and push it through the inner preheating groove until it comes out at the bottom edge of the holder plate.

5.5 Handling the eluent

Careful handling of the eluent ensures stable analysis results. Keep the following general measures in mind when handling the eluent:

- The supply bottle with the eluent must be connected as indicated in *chapter 3.7, page 22*. This is particularly important for eluents with volatile solvents (e.g. acetone).
- Avoid condensation in the eluent bottle. Drop formation can change the concentration ratio in the eluent.
- In the case of very sensitive measurements, we recommend that the eluent be stirred constantly with a magnetic stirrer (e. g. the 2.801.0010 with 6.2070.000).
- To protect the IC system from foreign particles, we recommend aspirating the eluent via an aspiration filter (*see Chapter 3.7, page 22*) (6.2821.090). This aspiration filter must be replaced as soon as it turns yellow but at least every 3 months.

5.5.1 Manufacturing eluent

Chemicals used for manufacturing eluents must have a purity grade of at least "p.a.". They may be diluted only by using ultrapure water (resistance > 18.2 MΩ*cm). (These specifications apply generally for all reagents used in ion chromatography.)

Newly manufactured eluents always need to be microfiltered (0.45 µm filter).

The composition of the eluent plays a critical role in chromatographic analysis:

Concentration	An increase in the concentration generally leads to shorter retention times and faster separation, but also to a higher background conductivity signal.
pH	pH changes lead to shifts in dissociation equilibria and thus to changes in retention times.
Organic solvents	Adding organic solvents (e.g. methanol, acetone or acetonitrile) to a watery eluent generally speeds up lipophilic ions.

5.5.2 Changing the eluent

Ensure that no precipitates can form when changing the eluent. Immediately successive solutions must be miscible. If the system must be rinsed with organic solvents, several solvents with rising or falling lipophilicity must be used.



NOTE

To change the eluent, remove the guard column and the separation column. Connect the capillaries using a coupling (6.2744.040) and two pressure screws (6.2744.070).

5.6 Servicing the eluent degasser

The pieces of connection tubing are connected to the eluent degasser with clamping screws.

Proceed as follows if you have to loosen and reconnect the connection tubing at the eluent degasser:

Accessories

For this step, you need the following accessories:

You can find these parts in the accessory kit: *Vario/Flex Basic* (6.5000.000)

- Wrench (6.2621.050)

Loosening the connecting tubing

- 1 ▪ Loosen the clamping screws with the wrench.
 - Unscrew the clamping screws by hand and pull them out of the connector.



Connecting the connecting tubing

- 1 ■ Insert the clamping screws on the connector and screw them in by hand.
 - Tighten the clamping screws with the wrench.

5.7 Notes on operating the high-pressure pump



CAUTION

The pump head is filled ex works with methanol/ultrapure water. Ensure that the eluent used is miscible with this solvent.

Keep the following recommendations in mind in order to protect the high-pressure pump from damage as much as possible during operation:

- To protect the high-pressure pump from **foreign particles**, we recommend filtering the eluent through a filter with a pore size of 0.45 µm and aspirating it via an aspiration filter (6.2821.090).
- Ensure that no precipitates can form when changing the eluent. Salt crystals between the piston and seal cause abrasive particles that can find their way into the eluent. These particles lead to contaminated valves, an increase in pressure and, in extreme cases, scratched pistons and thus to leakages in the high-pressure pump. Immediately successive solutions must always be miscible. If the system must be rinsed with organic solvents, use several solvents with rising or falling lipophilicity.
- In order to protect the pump seals, ensure that the pump is never operated dry. Therefore ensure that the eluent supply is correctly connected and that there is enough eluent in the eluent bottle each time before turning on the pump.

5.8 Servicing the high-pressure pump



NOTE

You can find a video sequence for this task in the *Multimedia Guide IC Maintenance* or on the Internet at <http://ic-help.metrohm.com/>.

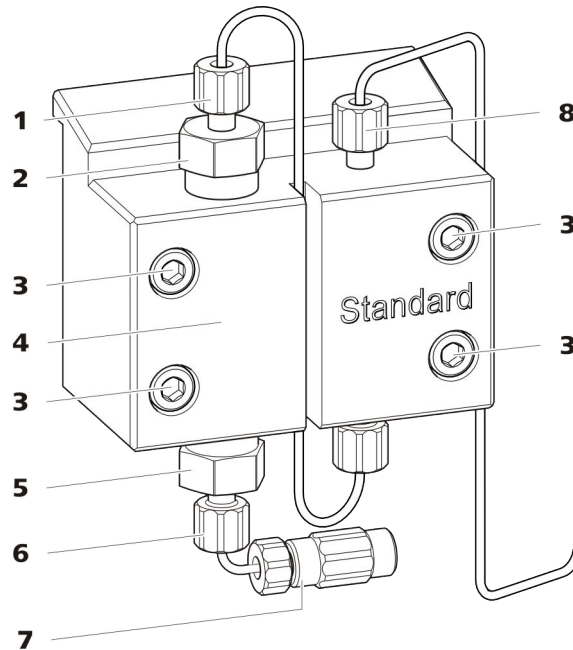

Figure 14 High-pressure pump – Parts

1 Pressure screw, short (6.2744.070) Fastened to the outlet valve holder.	2 Outlet valve holder
3 Fastening screw	4 Pump head
5 Inlet valve holder	6 Pressure screw, short (6.2744.070) Fastened to the inlet valve holder.
7 Eluent aspiration tubing connector Consists of a coupling with a pressure screw.	8 Pressure screw, short (6.2744.070) Fastened to the pump output.

Maintenance interval The following parts of the high-pressure pump must be serviced at least once per year:

- Inlet valve (6.2824.170)
- Outlet valve (6.2824.160)
- Piston seal (6.2741.020)
- Zirconium oxide piston (6.2824.070)

Maintenance tasks can also be carried out if the following problems occur:



- Unstable baseline (pulsations, flow fluctuations)



CAUTION

Maintenance work on the high-pressure pump may not be carried out unless the **instrument is switched off**.

Recommended procedure

We recommend the following procedure for the maintenance of the pump head:

1. Service the inlet valve and the outlet valve.
2. Remove the pump head.
3. Service both pistons, one after the other.
 - a. Remove piston.
 - b. Dismantle the piston.
 - c. Replace the piston seal.
 - d. Replace the zirconium oxide piston.
 - e. Assemble the piston.
 - f. Insert the piston.
4. Reinstall the pump head.

You can find brief video sequences on the following maintenance steps on the Internet at <http://ic-help.metrohm.com/>.

Servicing the outlet valve and inlet valve

Accessories

For this step, you need the following accessories:

You can find these parts in the accessory kit: *Vario/Flex Basic* (6.5000.000).

- Adjustable wrench (6.2621.000)

Cleaning the outlet valve

Spare parts

If the outlet valve cannot be cleaned, you will need a new outlet valve (6.2824.160) for this step.

1 Removing the outlet valve

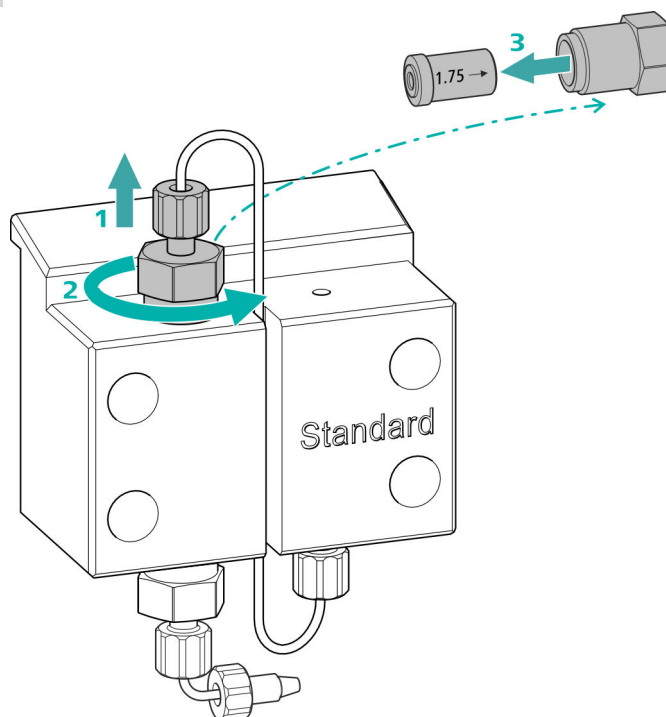

- Unscrew the connection capillary to the auxiliary piston from the outlet valve holder (14-2) (1).
- Start by loosening the outlet valve holder with the adjustable wrench and then unscrew it by hand (2) and remove it.
- Remove the outlet valve from the outlet valve holder (3).

2 Cleaning the outlet valve

- Start by rinsing the outlet valve in the direction of eluent flow using a wash bottle filled with ultrapure water, RBS™ solution or acetone. (The direction of eluent flow is marked on the valve by an arrow.)
The rinsing solution must come out at the valve outlet.
If no more solution comes out, then the valve is blocked.
- Rinse the outlet valve in the direction opposite the eluent flow using a wash bottle filled with ultrapure water, RBS™ solution or acetone.
The rinsing solution may only come out at the valve outlet.

The outlet valve must be replaced if it is still clogged after cleaning.



3 Reinserting the outlet valve into the pump head

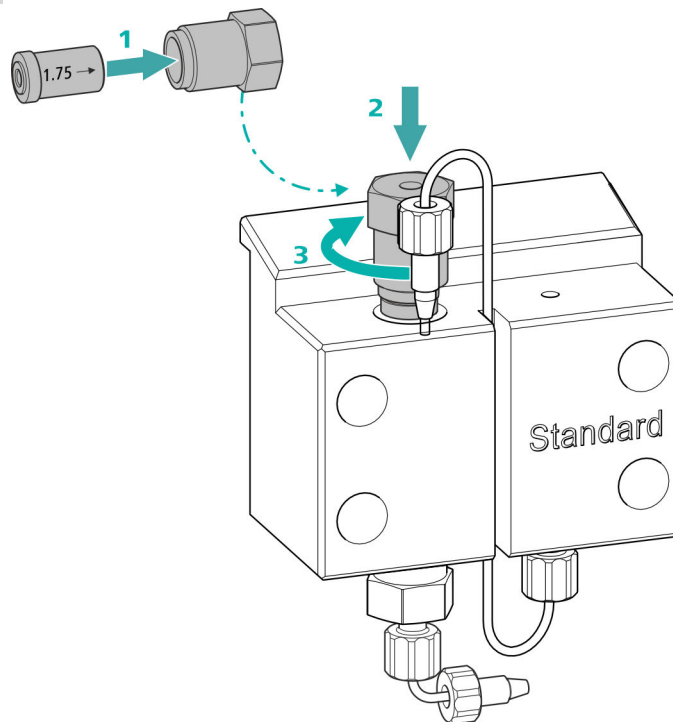

- Insert the outlet valve into the outlet valve holder (the seal must be visible) (1).
- Screw the outlet valve holder up into the pump head (2) and tighten it firmly by hand and then retighten it one additional $\frac{1}{4}$ turn using the adjustable wrench (3).
- Tighten the connection capillary to the auxiliary piston back onto the outlet valve holder.

Cleaning the inlet valve

Spare parts

If the inlet valve cannot be cleaned, you will need a new inlet valve (6.2824.170) for this step.

1 Removing the inlet valve

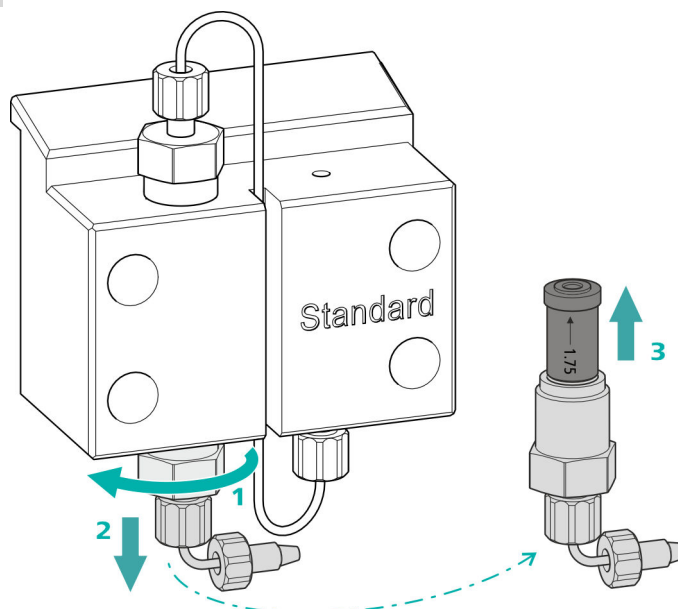

- Unscrew the connection capillary to the connection of the eluent aspiration tubing (14-7).
- Start by loosening the inlet valve holder with the adjustable wrench (1) and then unscrew it by hand (2) and remove it.
- Remove the inlet valve from the inlet valve holder (3).

2 Cleaning the inlet valve

- Start by rinsing the inlet valve in the direction of eluent flow using a wash bottle filled with ultrapure water, RBS™ solution or acetone. (The direction of eluent flow is marked on the valve by an arrow.)

The rinsing solution must come out at the valve outlet.

If no more solution comes out, then the valve is blocked.

- Rinse the inlet valve in the direction opposite the eluent flow using a wash bottle filled with ultrapure water, RBS™ solution or acetone.

The rinsing solution may only come out at the valve outlet.

The inlet valve must be replaced if it is still clogged after cleaning.



3 Reinserting the inlet valve into the pump head

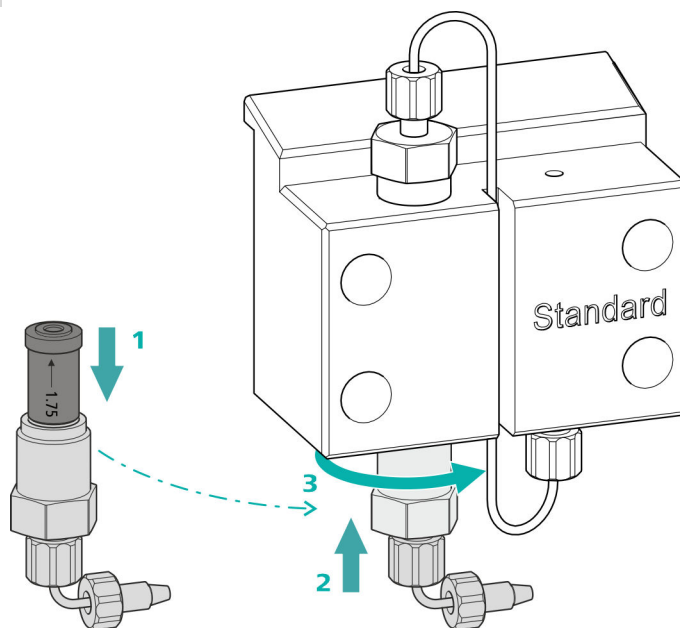

- Insert the inlet valve into the inlet valve holder (the seal must be visible) (1).
- Screw the inlet valve holder up into the pump head (2) and tighten it firmly by hand and then retighten it one additional $\frac{1}{4}$ turn using the adjustable wrench (3).
- Refasten the connection capillary to the connection of the eluent aspiration tubing (14-7).

Removing the pump head

Accessories

For this step, you need the following accessories:

You can find these parts in the accessory kit: *Vario/Flex Basic* (6.5000.000).

- 4 mm hex key (6.2621.030)

Removing the pump head

Prerequisites:

- Is the high-pressure pump switched off?
- Has the pressure been released?
- Is the instrument switched off?

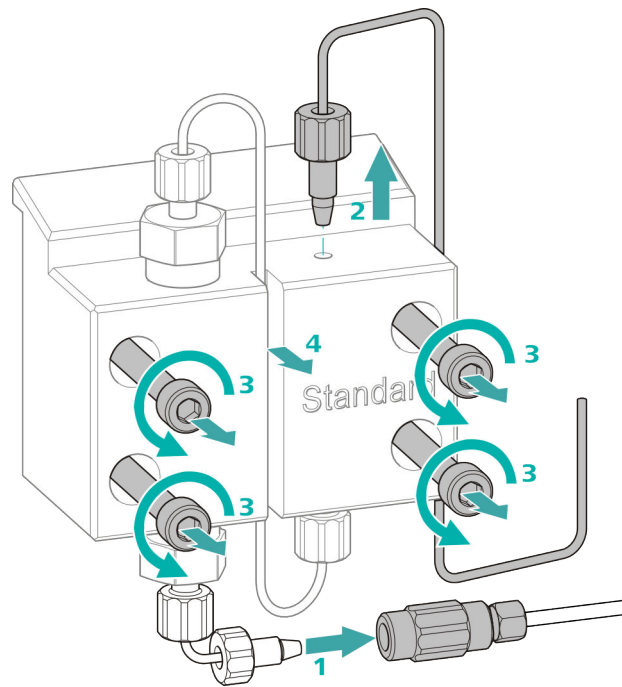

- 1** Release the coupling from the pressure screw and seal it with a stopper.
- 2** Unscrew and remove the pressure screw on the pump head's outlet (14-8).
- 3** Loosen and remove the four fastening screws (14-3) using the hex key.
- 4** Remove the pump head (14-4).

Servicing the piston

Carry out the following work on both pistons in turn.

Servicing a piston consists of the following tasks:

1. Replace the piston seal.
2. Clean or replace the zirconium oxide piston.
3. Reinstall the piston.

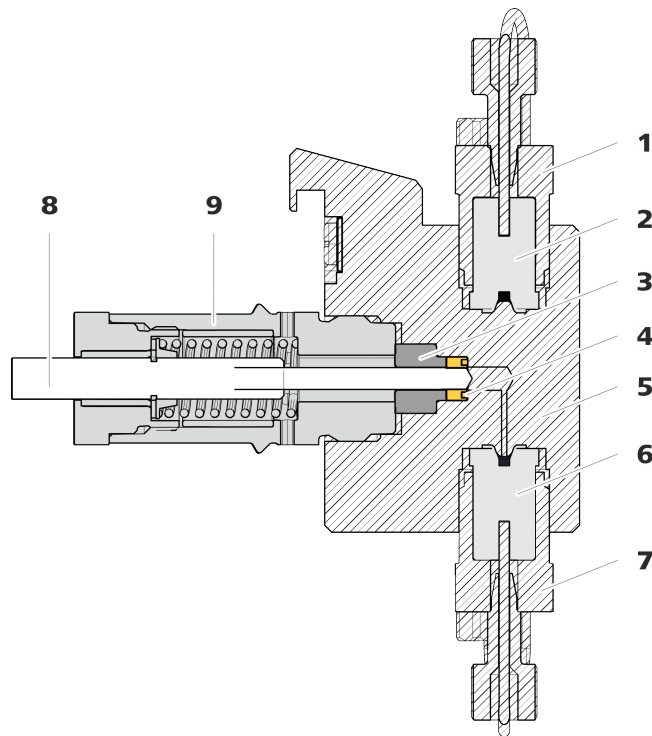

Figure 15 High-pressure pump – Cross-section

1	Outlet valve holder	2	Outlet valve (6.2824.160)
3	Backup ring	4	Piston seal (6.2741.020)
5	Pump head	6	Inlet valve (6.2824.170)
7	Inlet valve holder	8	Zirconium oxide piston (6.2824.070)
9	Piston cartridge		

Accessories

For this step, you need the following accessories:

You can find these parts in the accessory kit: *Vario/Flex Basic* (6.5000.000).

- Adjustable wrench (6.2621.000)
- Tool for piston seals (6.2617.010) consisting of a tip (16-1) for removing the old piston seal and a sleeve (16-2) for inserting the new piston seal.

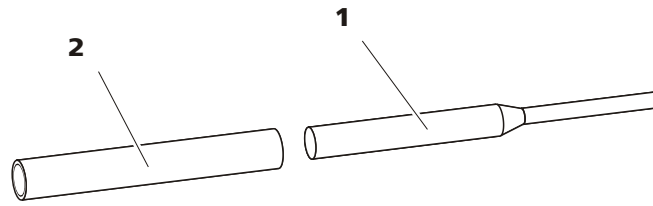

Figure 16 Tool for piston seal (6.2617.010)

1 Tip

2 Sleeve

Spare part

For this step, you need a new piston seal (6.2741.020).

Replacing the piston seal

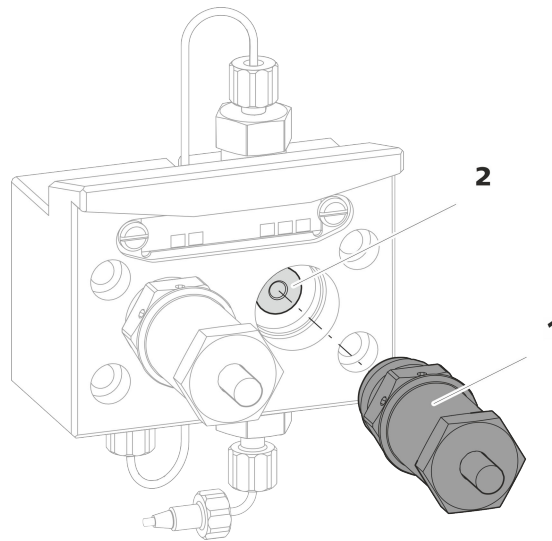

Figure 17 Removing the piston cartridge from the pump head

1 Piston cartridge

2 Backup ring

1 Removing the piston cartridge

Loosen the piston cartridge (17-**1**) using the adjustable wrench and then unscrew it from the pump head by hand. Set it aside.

2 Removing the backup ring

Shake the backup ring (17-**2**) out of the piston opening. Set it aside.



3 Removing the old piston seal



CAUTION

Screwing the (6.2617.010) special tool for the piston seal into the piston seal destroys this completely!



CAUTION

Avoid touching the sealing surface in the pump head with the tool!

Only screw the tip (16-1) of the tool for the piston seal far enough into the piston seal that the seal can be pulled out.

4 Inserting the new piston seal into the tool

Insert the new piston seal into the recess of the sleeve (18-1) of the tool for piston seal. The sealing spring must be visible from the outside.

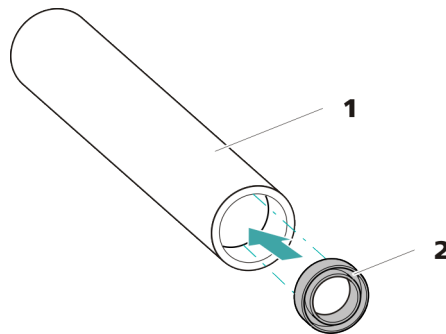

Figure 18 Inserting the piston seal into the tool

1 Tool for piston seal (6.2617.010)
Sleeve for inserting the new piston seal.

2 Piston seal (6.2741.020)

5 Inserting the new piston seal into the pump head

Guide the sleeve (16-2) of the tool for the piston seal with inserted piston seal into the pump head. Press the seal into the pump head recess using the wide end of the tip (16-1) of the tool.

Cleaning or replacing the zirconium oxide piston

Prerequisites:

- The pump head has been removed (see "Removing the pump head", page 58).
- The piston cartridge is removed (see "Replacing the piston seal", page 61).

For this task, you need the following accessories:

- Zirconium oxide piston (6.2824.070)
- Adjustable wrench (6.2621.000) from the accessory kit: *Vario/Flex Basic* (6.5000.000).

1 Breaking down the piston cartridge



CAUTION

Inside the piston cartridge there is a taut spring that can launch out of the piston cartridge if the tension is released suddenly.

When opening the piston cartridge, counteract the pressure from the spring and carefully unscrew the cartridge.

- Loosen the piston cartridge's screw with an adjustable wrench and carefully unscrew the screw by hand while counteracting the pressure from the taut spring.
- Remove the zirconium oxide piston and place it on a paper towel.
- Remove the spring retainer, the spring and the inner plastic sleeve from the piston cartridge and lay them next to the piston.
- Place the backup ring you put aside with the remaining parts.

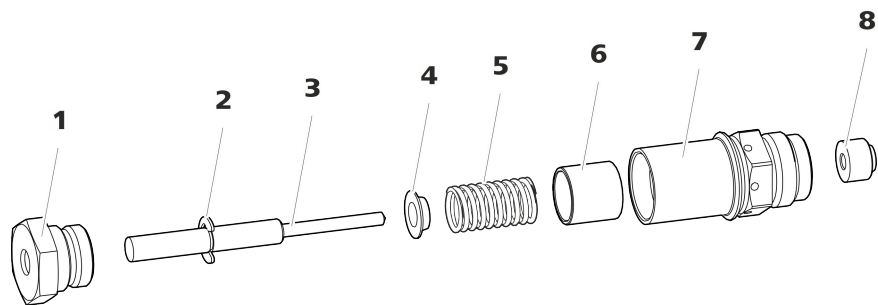

Figure 19 Parts of the piston cartridge

1	Piston cartridge screw	2	Retaining washer
3	Zirconium oxide piston (6.2824.070)	4	Spring retainer
5	Spring (6.2824.060)	6	Inner plastic sleeve Protects from metallic abrasion.
7	Piston cartridge	8	Backup ring



2 Cleaning the parts of the piston cartridge

- If the zirconium oxide piston has become contaminated due to abrasion or deposits, then clean it using a fine abrasive cleaning powder, rinse it using ultrapure water until it is free of particles and dry it.

The zirconium oxide piston must be replaced if it is heavily contaminated or scratched.

- Rinse the other parts of the piston with ultrapure water and dry with a lint-free cloth.

3 Replacing the zirconium oxide piston

- Remove the retaining washer (19-2) from the old piston. If the retaining washer sits too tightly, use a pointed object to loosen the retaining washer.
- Assemble the retaining washer at the same point on the new piston.

4 Putting the piston cartridge together

- Insert the inner plastic sleeve, the spring and the spring retainer into the piston cartridge.
- Slide the zirconium oxide piston carefully into the piston cartridge until its tip emerges from the small opening of the piston cartridge.
- Attach the screw and tighten it by hand.

Mounting the piston

1 Reinserting the backup ring

Clean the backup ring (15-3) with ultrapure water and reinsert it.

2 Reinserting the piston cartridge

Screw the assembled piston cartridge back into the pump head and tighten, first by hand, then also using an adjustable wrench by approx. 15°.

Clean the second piston cartridge in the same way.

Mounting the pump head

For this step, you need the following accessories:

You can find these parts in the accessory kit: *Vario/Flex Basic* (6.5000.000).

Accessories

- 4 mm hex key (6.2621.030)

Mounting the pump head



NOTE

The pump head cannot be mounted the wrong way, as it has fastening bolts with different bore hole depths, i.e., one fastening bolt is longer than all others. The bore hole with the greatest depth must therefore be aligned with the longest bolt.

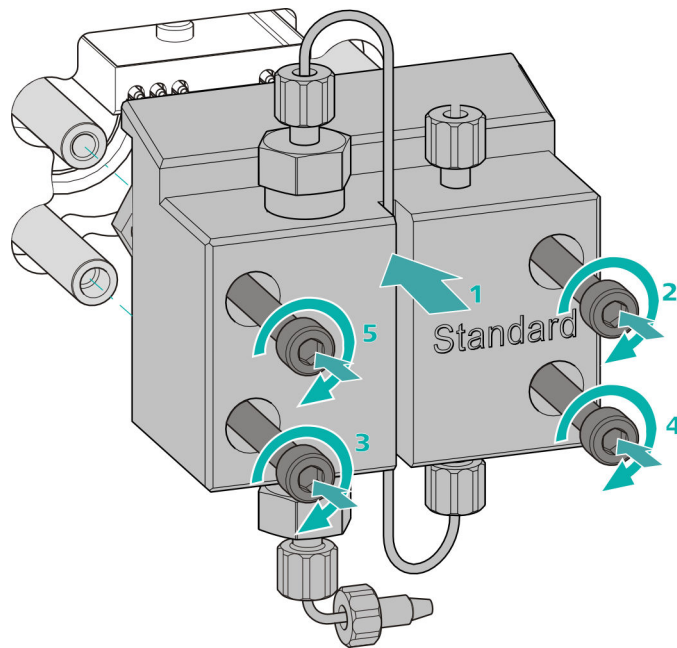

- 1
 - Push the pump head onto the four fastening bolts (1).
 - Tighten the four fastening screws using the hex key (6.2621.030) alternating crosswise.



Connecting the entry and exit for the high-pressure pump

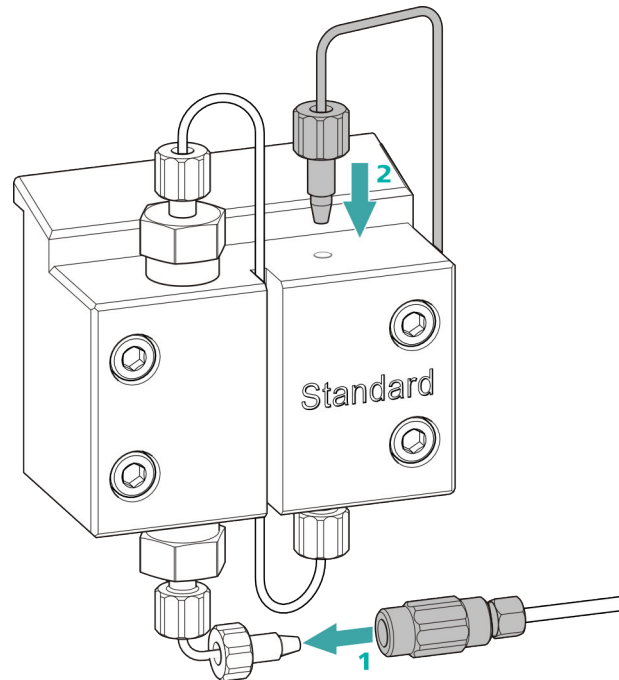

- 1
 - Remove the stopper from the coupling. Tighten the coupling to the pressure screw located on the pump head inlet capillary (1).
 - Reconnect the pump head outlet capillary to the pump head outlet (2).

5.9 Servicing the inline filter



NOTE

You can find a video sequence for this task in the *Multimedia Guide IC Maintenance* or on the Internet at <http://ic-help.metrohm.com/>.

Maintenance interval

The filter must be replaced at least every 3 months; it may need to be replaced more frequently, depending on the application.

Accessories

For this task, you need the following accessories:

- Two adjustable wrenches (6.2621.000) from the accessory kit: Vario/Flex Basic (6.5000.000)
- Tweezers
- A new filter from the packaging (6.2821.130)

Removing the filter

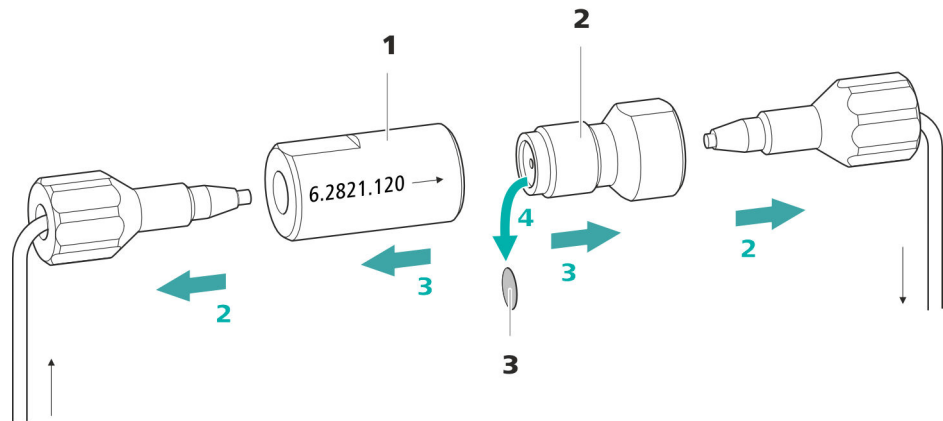

Figure 20 Inline filter – Removing the filter

1 Filter housing

Inline filter housing. Part of the accessories (6.2821.120).

2 Filter screw

Screw for the inline filter. Part of the accessories (6.2821.120).

3 Filter (6.2821.130)

Pack contains 10 pieces.

1 Shutting off the flow

Switch off the high-pressure pump in the software.

2 Removing the inline filter

Unscrew both pressure screws from the inline filter.

3 Unscrewing the filter screw

Use two adjustable wrenches (6.2621.000) to loosen the filter screw (20-2) from the filter housing (20-1) and unscrew it by hand.

4 Removing the filter

Remove the old filter (20-3) using tweezers.



Inserting a new filter

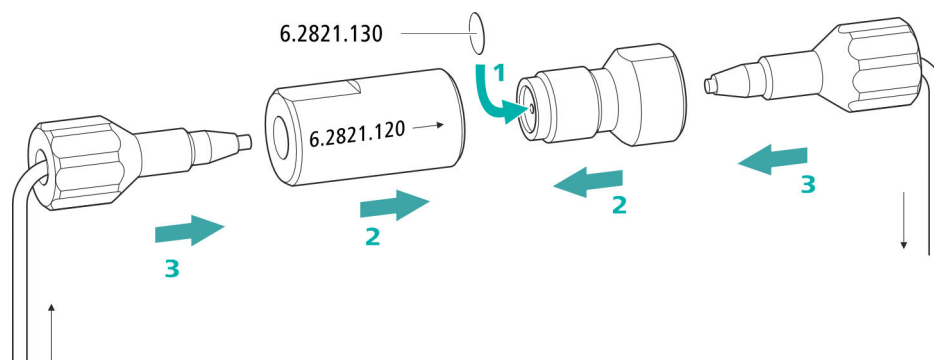

1 Inserting a new filter

- Use tweezers to carefully place a new filter into the filter screw (20-2) so that it is flat and press it firmly into place with the rear of the tweezers.

2 Installing the filter screw

- Screw the filter screw (20-2) back into the filter housing (20-1) and tighten by hand. Then use two adjustable wrenches (6.2621.000) to tighten it slightly.

3 Remounting the inline filter

- Screw pressure screws back onto the inline filter. Take care to ensure that the flow direction matches that inscribed on the inline filter.

4 Rinsing the inline filter

- Dismantle the guard column (if present) and the separation column and replace with a coupling (6.2744.040).
- Rinse the instrument with eluent.
- Reinsert the columns after 10 minutes.

5.10 Servicing the pulsation absorber



CAUTION

The pulsation absorber is maintenance-free and must not be opened.

5.11 Injection valve

Maintenance on the injection valve is best performed by specialist personnel from Metrohm during annual service.

5.12 Servicing the detector

Follow the maintenance instructions in the the detector's manual.

5.13 Rinsing the sample path

Before a new sample is measured, the sample path must be rinsed with it long enough to prevent the measuring result from being falsified by the previous sample (sample carry-over).

The time required to rinse the sample path with the new sample is called the rinsing time. The rinsing time depends on the transfer time.

The transfer time corresponds to the time the sample needs to flow from the sample vessel to the end of the sample loop. The transfer time depends on the following factors:

- The pump capacity of the peristaltic pump or of the Dosino that is used for the sample transfer.
- The total capillary volume
- The volume of the gas removed from the sample by the sample degasser (if a sample degasser is present and connected)

The transfer time can be determined as follows:

Determining the transfer time

1 Emptying the sample path

Pump air through the sample path (pump tubing, tubing connections, capillary in the degasser, sample loop) for several minutes until all liquid is displaced by the air.

**2 Unscrewing the sample loop**

Unscrew the end of the sample loop.

3 Aspirating the sample and measuring the time

Aspirate a sample typical for the later application and use a stop-watch to measure the time the sample needs to go from the sample vessel to the end of the sample loop.

The time upon stopping the watch is the "transfer time".

4 Tightening the sample loop again

Tighten the sample loop again.

If the sample is injected automatically, the rinsing time must be at least three times the **transfer time**.

Checking the rinsing time

You can determine if the applied rinsing time is sufficient by measuring the sample carry-over directly. Proceed as follows to do this:

1 Preparing two samples

- **Sample A:** A typical sample for the application.
- **Sample B:** Ultrapure water.

2 Determining "Sample A"

Allow "Sample A" to run through the sample path for the duration of the rinsing time; inject and then measure it.

3 Determining "Sample B"

Allow "Sample B" to run through the sample path for the duration of the rinsing time; inject and then measure it.

4 Calculating the sample carry-over

The sample carry-over corresponds to the ratio of the peak areas of the measurement from Sample B to the measurement from Sample A. The smaller this ratio, the smaller the amount of sample carry-over. This ratio can be changed by varying the rinsing time. This can be used to determine the required rinsing time for the application.

5.14 Separation column

5.14.1 Separating efficiency

The analysis quality that can be attained depends in a large part on the separating efficiency of the separation column being used. The separating efficiency of the selected separation column must be sufficient for the current analysis problems. If difficulties arise, start by checking the quality of the separation column in each case by recording a standard chromatogram.

You can find detailed information on the separation columns available from Metrohm in the leaflet provided along with your separation column, in the **Metrohm IC Column Program** (available from your Metrohm representative) or on the Internet at <http://www.metrohm.com> in the Ion Chromatography product area. You can find information on special IC applications in the corresponding "**Application Bulletins**" or "**Application Notes**", which are available on the Internet at <http://www.metrohm.com> in the Applications area or free of charge upon request from your responsible Metrohm representative.

5.14.2 Protecting the separation column

We recommend using the following protective measures so that the separation column retains its separating efficiency for as long as possible:

- Microfilter both the sample and the eluent (0.45 µm filter) and aspirate the eluent via the aspiration filter (6.2821.090) as well.
- Always use a guard column. Information regarding which guard column is suitable for your separation column can be found in the **Metrohm IC Column Program** (which is available from your Metrohm representative), the leaflet provided along with your separation column or the product information about the separation column at <http://www.metrohm.com> (Ion Chromatography product area), or it can be obtained directly from your representative.
- Use the pulsation absorber.

5.14.3 Storing the separation column

Always store separation columns you do not need in a sealed and filled state according to the column manufacturer's specifications.

5.14.4 Regenerating the separation column

The separation column can be regenerated according to the column manufacturer's specifications if the separation characteristics of the column have deteriorated. You can find information on regenerating separation columns available from Metrohm on the leaflet provided with every column.

**NOTE**

Regeneration is intended as a last resort. It should not be carried out regularly.

5.15 Quality management and qualification with Metrohm

Quality management

Metrohm offers you comprehensive support in implementing quality management measures for instruments and software.

Qualification

Please contact your local Metrohm representative for support in qualification of instruments and software. The **Installation Qualification** (IQ) and **Operational Qualification** (OQ) are offered by Metrohm representatives as a service. They are carried out by trained employees using standardized qualification documents and in accordance with the currently applicable requirements of the regulated industry.

6 Troubleshooting

Problem	Cause	Remedy
Marked drop in pressure.	<i>Leak in the system.</i>	Check the capillary connections and seal leaks, if necessary (see Chapter 3.2, page 14).
The baseline has a large amount of noise.	<i>The eluent is not sufficiently degassed.</i>	Ensure that the connectors for the eluent degasser are firmly connected (see Chapter 5.6, page 51).
	<i>The eluent path has a leak.</i>	Check the eluent path and fix the leak. If necessary, tighten the pressure screws using a wrench (6.2739.000).
	<i>High-pressure pump – Contaminated pump valves.</i>	Clean the pump valves (see Chapter 5.8, page 53).
	<i>The eluent path is blocked.</i>	Check the eluent path and eliminate the blockage.
	<i>Contaminations in the eluent</i>	Check the quality of the chemicals and the water.
	<i>High-pressure pump – Defective piston seals.</i>	Replace the piston seals (see Chapter 5.8, page 53).
	<i>The pulsation absorber is not connected or is defective.</i>	Connect (see Chapter 3.11, page 27) or replace the pulsation absorber.
The baseline is drifting.	<i>Thermal equilibrium is not yet attained.</i>	Condition the instrument with the column thermostat enabled until the baseline is stable .
	<i>Leak in the system.</i>	Check all capillary connections and seal leaks, if necessary (see Chapter 3.2, page 14).
	<i>The organic solvent in the eluent is evaporating.</i>	<ul style="list-style-type: none"> ▪ Check the eluent bottle cap (see Chapter 3.7, page 22). ▪ Constantly stir the eluent.
The pressure in the system markedly increases.	<i>The inline filter (6.2821.120) is blocked.</i>	Replace the filter (6.2821.130) .



Problem	Cause	Remedy
	<i>Guard column – Blocked.</i>	Replace the guard column (see Chapter 3.20, page 37).
	<i>Separation column – Blocked.</i>	<ul style="list-style-type: none"> ▪ Regenerate the separation column (see Chapter 5.14.4, page 71). ▪ Replace the separation column (see "Connecting the separation column", page 41). Note: Samples should always be microfiltered .
	<i>Injection valve – blocked.</i>	Have the valve cleaned (by a Metrohm service engineer).
The retention times in the chromatogram have changed unexpectedly.	<i>Eluent - Incorrect concentration</i>	Create eluent with correct concentration.
	<i>Separation column – Diminished separating efficiency.</i>	<ul style="list-style-type: none"> ▪ Regenerate the separation column (see Chapter 5.14.4, page 71). ▪ Replace the separation column (see "Connecting the separation column", page 41).
	<i>The eluent contains gas bubbles.</i>	<ul style="list-style-type: none"> ▪ Ensure that the connectors for the eluent degasser are firmly connected . ▪ Deaerate the high-pressure pump (see Figure , page 36).
	<i>High-pressure pump – Defective.</i>	Request Metrohm Service.
Peak areas are lower than expected.	<i>Sample – There is a leak in the sample path.</i>	Find and fix the leak in the sample path.
	<i>Sample – The sample path is blocked.</i>	Find and eliminate the blockage in the sample path.
	<i>Sample – The sample loop is not (completely) filled.</i>	Adjust the transfer time for the sample (see "Determining the transfer time", page 69).
	<i>Sample – There are gas bubbles in the sample.</i>	Use the sample degasser .
Data of the separation column cannot be read.	<i>Column chip dirty.</i>	Clean the contact surfaces of the column chip with ethanol.
	<i>Column chip is defective.</i>	<ol style="list-style-type: none"> 1. Save column configuration in MagIC Net. 2. Notify Metrohm Service.

Problem	Cause	Remedy
Individual peaks are greater than expected.	<i>Sample – Sample carry-over from previous measurements.</i>	Check the rinsing time (see "Checking the rinsing time", page 70).
The background conductivity is too high.	<i>The incorrect eluent is being used.</i>	Change the eluent (see Chapter 5.5.2, page 51).
The retention times are poorly reproducible.	<i>The eluent path has a leak.</i>	Check all of the connections along the eluent path and fix the leak.
	<i>The eluent path is blocked.</i>	Check the eluent path and eliminate the blockage.
	<i>The eluent contains gas bubbles.</i>	<ul style="list-style-type: none"> ▪ Check the connectors of the eluent degasser . ▪ Deaerate the high-pressure pump (see Chapter 3.19, page 35).
Chromatograms have poor resolution	<i>Separation column – Diminished separating efficiency.</i>	<ul style="list-style-type: none"> ▪ Regenerate the separation column (see Chapter 5.14.4, page 71). ▪ Replace the separation column (see "Connecting the separation column", page 41).
Extreme spread of the peaks in the chromatogram. Splitting (dual peaks)	<i>Capillary connections – Dead volume in the system.</i>	Check the capillary connections (see Chapter 3.2, page 14) (use PEEK capillaries with an inner diameter of 0.25 mm between the injection valve and detector).
	<i>Guard column – Diminished efficiency.</i>	Replace the guard column (see Chapter 3.20, page 37).
	<i>Separation column – Dead volume at the column head.</i>	<ul style="list-style-type: none"> ▪ Install the separation column in the opposite flow direction (if the leaflet says this is permissible) and rinse into a beaker. ▪ Replace the separation column (see "Connecting the separation column", page 41).
Precision problems - the measured values are highly scattered.	<i>Injection valve – Sample loop.</i>	Check the installation of the sample loop (see "Optional: Exchanging the sample loop", page 29).
	<i>Sample – There are gas bubbles in the sample.</i>	Use the sample degasser .
	<i>Sample – The rinsing volume is too small.</i>	Increase the rinsing time (see Chapter 5.13, page 69).



Problem	Cause	Remedy
	<i>Injection valve – Defective.</i>	Request Metrohm Service.
Vacuum is not being built	<i>Eluent degasser – Vacuum connection on the rear of the instrument is not (tightly) sealed.</i>	<ul style="list-style-type: none">Seal the Vacuum connector tightly with a threaded stopper (6.1446.040).

7 Technical specifications

7.1 Reference conditions

The technical specifications listed in this chapter refer to the following reference conditions:

<i>Ambient temperature</i>	+25 °C (± 3 °C)
<i>Instrument status</i>	Operating > 40 minutes (in equilibrium)

7.2 Instrument

<i>IC system</i>	<ul style="list-style-type: none"> ▪ Metal-free IC system ▪ Compact system with modular design ▪ Up to two complete chromatographic systems in one housing
<i>Material</i>	Painted, CFC-free polyurethane hard foam, fire class V0
<i>Operating pressure range</i>	<ul style="list-style-type: none"> ▪ 0 - 50 MPa (500 bar) high-pressure pump ▪ 0 - 35 MPa (350 bar) standard PEEK system
<i>Intelligent components</i>	iPump, iDetector, iColumn, iCell, iReactor, Dosino, MagIC Net

7.3 Ambient conditions

<i>Operation</i>	
<i>Ambient temperature</i>	+5 - +45 °C
<i>Humidity</i>	20 - 80% relative humidity
<i>Storage</i>	
<i>Ambient temperature</i>	-20 - +70 °C
<i>Transport</i>	
<i>Ambient temperature</i>	-40 - +70 °C



7.4 Housing

Dimensions

<i>Width</i>	365 mm
<i>Height</i>	642 mm
<i>Depth</i>	380 mm

Controls

<i>Indicators</i>	LED standby indicator
<i>On/off switch</i>	On the rear of the instrument

7.5 Weight

2.940.1140	36.43 kg (without accessories)
------------	--------------------------------

7.6 Leak sensor

<i>Type</i>	Electronic, no calibration necessary
-------------	--------------------------------------

7.7 Column thermostat

<i>Type</i>	Thermostat using Peltier technology for two intelligent separation columns
<i>Adjustable temperature range</i>	0 - +80 °C, in 0.1 °C increments
<i>Heating</i>	Up to 50 °C above the ambient temperature
<i>Cooling</i>	Down to 20 °C below the ambient temperature
<i>Temperature reproducibility</i>	±0.2 °C
<i>Stability</i>	< 0.05 °C
<i>Heating time</i>	< 30 minutes from 20 to 50 °C
<i>Cooling time</i>	< 40 minutes from 50 to 20 °C

7.8 Eluent degasser

<i>Material</i>	Fluoropolymer
<i>Resistance to solvents</i>	No restriction (except PFC)
<i>Time to establish vacuum</i>	< 60 s

7.9 High-pressure pump

<i>Type</i>	<ul style="list-style-type: none"> ▪ Serial dual-piston pump ▪ Intelligent pump head recognition ▪ Chemically inert ▪ Metal-free pump heads ▪ Materials in contact with the eluent: PEEK, ZrO₂, PTFE/PE ▪ Self-optimizing flow and pressure
<i>Flow rate</i>	
<i>Adjustable flow range</i>	0.001 - 20 mL/min 0.01 - 5 mL/min with standard PEEK pump head
<i>Flow increment</i>	1 µL/min
<i>Reproducibility of the eluent flow</i>	< 0.1% deviation
<i>Pressure range</i>	
<i>Pump</i>	0 - 50.0 MPa (0 - 500 bar)
<i>Pump head</i>	0 - 35.0 MPa (0 - 350 bar) (applies for the standard PEEK pump head)
<i>Residual pulsation</i>	< 1%
<i>Safety shutdown</i>	
<i>Function</i>	Automatic shutdown upon reaching the pressure limits
<i>Maximum pressure limit</i>	<ul style="list-style-type: none"> ▪ Adjustable from 0.1 - 50 MPa (1 - 500 bar) ▪ The pump is automatically shut down at the first piston stroke above the maximum limit value
<i>Minimum pressure limit</i>	<ul style="list-style-type: none"> ▪ Adjustable from 0 - 49 MPa (0 - 490 bar) ▪ The shutdown mechanism is inactive at 0 MPa ▪ The shutdown mechanism becomes active two minutes after system start ▪ The pump is automatically shut down after three piston strokes below the minimum pressure limit



<i>Gradient capability</i>	Isocratic or gradient (extendable to quaternary)
<i>Profile</i>	Step, linear, convex and concave
<i>Resolution</i>	< 1 nL/min

7.10 Injection valve

<i>Actuator switching time</i>	typ. 100 ms
<i>Maximum operating pressure</i>	35 MPa (350 bar)
<i>Material</i>	PEEK

7.11 Detector

You can find the technical specifications for the detector in the manual for the detector.

7.12 Sample degasser

<i>Material</i>	Fluoropolymer
<i>Resistance to solvents</i>	No restriction (except PFC)
<i>Time to establish vacuum</i>	< 60 s

7.13 Power connection

<i>Required supply voltage</i>	100 - 240 V \pm 10% (autosensing)
<i>Required frequency</i>	50 - 60 Hz \pm 3 Hz (autosensing)
<i>Power consumption</i>	<ul style="list-style-type: none"> ▪ 65 W for typical analysis application ▪ 25 W standby (conductivity detector to 40 °C)
<i>Power supply unit</i>	<ul style="list-style-type: none"> ▪ Up to 300 W maximum, electronically monitored ▪ internal fuse 3.15 A

7.14 Interfaces

USB

Input 1 USB upstream, type B (labeled **PC** for connecting to a computer)

Output 2 USB downstream, type A (labeled **USB 1** and **USB 2**)

MSB

2 MSB 8-pin Mini DIN (female) (labeled **MSB 1** and **MSB 2** for Dosino, stirrer, remote lines, etc.)

Detector

2 15-pin high-density D-sub (female) (labeled **Detector 1** and **Detector 2**)

Column recognition

3 (including 2 in the column thermostat)

Leak sensor

1 jack plug (labeled **Leak Sensor**)

Further connections

- 1 15-pin D-sub (female) (labeled **Extension Module**)

Index

A

Ambient conditions 77
 Aspiration filter (6.2821.090) 50
 Aspiration tubing for eluent 22

B

Baseline
 Condition 44
 Unstable 54

C

Capillaries
 Installation 14
 Carry-over 69
 Clean
 Inlet valve 57
 Outlet valve 55
 Column
 see "Separation column" 39
 Column recognition 81
 Column thermostat
 Installation 21
 Technical specifications 78
 Computer connection 33
 Conditioning 44
 Connect
 To computer 33
 To power grid 34
 Connection
 Mains 80
 Connections
 Installation 14
 Contamination
 High-pressure pump 52
 Valves for the high-pressure
 pump 54
 Crystallization
 High-pressure pump 52

D

Degasser
 Sample degasser 31
 Degassing
 Eluent 26
 Detector
 Interface 81
 Dimensions 78
 Door 48
 Drainage tubing
 Installation 19

E

Electrostatic charge 4
 Eluent
 Aspirate 22
 Change 51
 Manufacturing 50
 Eluent bottle
 Installation 22
 Eluent degasser
 Technical specifications 79
 Equilibration 36, 43

F

Feed-through
 For cables 10
 For capillaries 10
 Filter
 Aspiration filter 50
 see "Inline filter" 27
 Flow fluctuations 54
 Flow increment 79
 Flow range 79
 Flow rate 79
 Frequency 80

G

Grip
 Also see "Handle" 17
 Guard column
 Installation 37
 Rinse 39

H

Handle 17
 Heating
 Also see "Column thermostat"
 21
 High-pressure pump
 Maintenance 53
 Protection 19, 52
 Technical specifications 79
 Housing 78
 Humidity 77

I

IC column
 see "Separation column" 39
 Injection valve 2
 Installation 28
 Maintenance 69

 Technical specifications 80
 Inline filter 27
 Installation
 Column thermostat 21
 Connections 14
 Drainage tubing 19
 Eluent bottle 22
 Guard column 37
 Injection valve 28
 Leak sensor 21
 Pulsation absorber 27
 Sample degasser 31
 Separation column 39
 Installation qualification 72
 Interface
 MSB 81
 USB 81
 Interfaces 81
 Further connections 81
 Leak sensor 81

L

Leak sensor
 Installation 21
 Interface 81
 Technical specifications 78
 Leak-tightness 37
 Leakage 54
 Leaky piston seals 54
 Loop
 See also "Sample loop" 28

M

Maintenance
 High-pressure pump 53
 Injection valve 69
 Maintenance agreement 72
 MSB 81

O

Operational qualification 72

P

Piston of the high-pressure pump
 54
 Piston seal 54
 Power connection 34, 35, 80
 Power consumption 80
 Power cord 35
 Power supply unit 80

Index

- Precipitate 52
Pressure increase 52
Pressure limit 79
Pressure range 79
Protection
 Inline filter 27
Pulsation 54
Pulsation absorber
 Installation 27
- Q**
Quality management 72
- R**
Reference conditions 77
Regeneration 46
Rinse
 Guard column 39
 Sample path 69
 Separation column 42
Rinsing time 70
- S**
Safety instructions 3
Safety shutdown 79
Sample
 Carry-over 69
 Sample loop 28
 Transfer time 69
Sample degasser
 Installation 31
 Technical specifications 80
Sample loop 28
Sample path
 Rinse 69
Separation column
 Installation 39
 Protection 2, 27, 71
 Regeneration 71
 Rinse 42
 Separating efficiency 71
 Storage 71
Service 4, 46
Shutting down 47
Storage 77
Supply voltage 4, 80
- T**
Technical specifications
 Column thermostat 78
 Detector 81
 Eluent degasser 79
 High-pressure pump 79
Injection valve 80
Interfaces 81
Leak sensor 78
Reference conditions 77
Sample degasser 80
Temperature 77
Thermostat
 Also see "Column thermostat"
 21
Transfer time 69
Transport 77
 Grip 17
Transport locking screws 18
Tubings
 Installation 14
- U**
USB 81
- V**
Vacuum pump
 Protection 19
Valve
 See also "Injection valve" 28