

Column manual

Metrosep A Supp 4 (6.1006.XX0 / 6.01021.XX0)

Manual

8.107.8051EN / 2017-11-30



Metrohm AG
CH-9100 Herisau
Switzerland
Phone +41 71 353 85 85
Fax +41 71 353 89 01
info@metrohm.com
www.metrohm.com

Column manual

**Metrosep A Supp 4 (6.1006.XX0 /
6.01021.XX0)**

Manual

Technical Communication
Metrohm AG
CH-9100 Herisau
techcom@metrohm.com

This documentation is protected by copyright. All rights reserved.

This documentation has been prepared with great care. However, errors can never be entirely ruled out. Please send comments regarding possible errors to the address above.

Table of contents

1	General information	1
1.1	Ordering information	1
1.2	Technical specifications	2
2	Key aspects of working with separation columns	4
3	Eluent production	8
3.1	Chemicals	8
3.2	Production of standard eluent	8
4	Start-up	10
4.1	Connecting and rinsing the guard column	10
4.2	Connecting the separation column	12
4.3	Conditioning	16
5	Applications	18
5.1	Standard chromatogram	18
5.2	Effects of temperature	20
5.3	Eluent flow rate variation	21
5.4	Variation of the eluent	23
5.5	Wastewater analysis Herisau waste treatment plant	31
5.6	Organic acids	32
5.7	Determination of fluoride, chloride, nitrite, nitrate and sulfate in mineral water	34
5.8	Determination of chloride in system health check solution in heating systems	35
5.9	Non-suppressed conductivity determination of hydroxylamine disulfonate	36
5.10	Determination of phosphate and citrate in blood clotting solutions	37
5.11	Determination of iodate, chloride, nitrate, sulfate and iodide using conductivity determination and MiPT	38
6	Troubleshooting	40
6.1	Regeneration	40
6.2	Decreasing resolution / peak shapes	42



6.3	Unstable retention times	42
6.4	Unknown peaks	43
6.5	Increasing backpressure	43
7	Literature	44

1 General information

This extremely robust anion separation column has very good separation properties. The 9- μm particle size guarantees a greater tolerance towards fine particles. It is particularly suitable for routine tasks in waste water analysis.

1.1 Ordering information

Table 1 4-mm columns

Order number	Designation
6.1006.430	Metrosep A Supp 4 - 250/4.0

Table 2 2-mm columns

Order number	Designation
6.01021.230	Metrosep A Supp 4 - 250/2.0

Table 3 4-mm guard columns

Order number	Designation
6.01021.500	Metrosep A Supp 4 Guard/4.0
6.01021.510	Metrosep A Supp 4 S-Guard/4.0

Table 4 2-mm guard columns

Order number	Designation
6.01021.600	Metrosep A Supp 4 Guard/2.0
6.01021.610	Metrosep A Supp 4 S-Guard/2.0



1.2 Technical specifications

<i>Column material</i>	Polyvinyl alcohol with quaternary ammonium groups		
<i>Particle size</i>	9 µm		
<i>Dimensions</i>	Order number	Dimensions	
	6.1006.430	250 x 4.0 mm	
	6.01021.230	250 x 2.0 mm	
<i>pH range</i>	3 to 12		
<i>Temperature range</i>	20 to 60 °C		
<i>Recommended standard temperature</i>	25 °C		
<i>Maximum pressure</i>	4 mm: 12 MPa (120 bar) 2 mm: 15 MPa (150 bar)		
<i>Flow rate</i>	Order number	Recommended flow rate	Maximum flow rate
	6.1006.430	1.0 mL/min	2.0 mL/min
	6.01021.230	0.25 mL/min	0.7 mL/min
<i>Standard eluent</i>	1.8 mmol/L sodium carbonate, 1.7 mmol/L sodium hydrogen carbonate		
<i>Permitted organic additives</i>			
<i>In the eluent</i>	0 to 100% acetonitrile, acetone and methanol		
<i>In the sample matrix</i>	0 to 100% acetonitrile, acetone and methanol		
<i>Capacity</i>	Order number	Capacity	
	6.1006.430	37 µmol (Cl ⁻)	
	6.01021.230	11 µmol (Cl ⁻)	
<i>Preparation</i>	<ol style="list-style-type: none"> 1. Use a flow gradient to set the column to the standard flow within 2 minutes. 2. Wait until the baseline sets. 		
<i>Storage</i>	Store the column in standard eluent.		
<i>Typical pressure</i>	For columns with a guard column under standard conditions with chemical suppression:		



Order number	Typical pressure
6.1006.430	5.3 ± 2 MPa
6.01021.230	4.2 ± 2 MPa

Column housing

Smart column with a chip, called an iColumn, made of PEEK

Application

Determination of inorganic anions and small organic anions with chemical or sequential suppression. The column is also suitable for non-suppressed analysis with phthalic acid as eluent.



2 Key aspects of working with separation columns

<i>Storage</i>	Once the backpressure in your ion chromatograph has dissipated, remove the column at ambient temperature. Seal the column at both ends using the original stoppers (6.2744.060). Store it in the standard eluent and, ideally, at a temperature between 4 and 8 °C.
<i>Bacterial growth</i>	<p>Bacterial growth significantly affects chromatography and ruins separation columns. A vast array of problems in chromatography are caused by the growth of algae, bacteria and fungi.</p> <p>In order to prevent bacterial growth, always use fresh eluents, rinsing solutions and regeneration solutions. Do not use any solutions that have not been used for a prolonged period. We recommend cleaning all vessels as follows before filling them:</p> <ol style="list-style-type: none">1. Thoroughly rinse with ultrapure, UV-treated water (> 18.2 MΩ).2. Swirl a methanol-water or acetone-water mixture around in the vessel.3. Rinse again with ultrapure water. <p>If you notice the growth of bacteria or algae despite these precautionary measures, add 5% methanol or acetonitrile to the eluent.</p>
<i>Chemical quality</i>	All chemicals must have at least a quality of p.a. or puriss. Standard solutions must be intended specifically for ion chromatography.
<i>Chemical stress</i>	<p>Even though specifications may indicate that separation phases do cover a large pH range, this does not mean they are chemically inert. Separation columns last longest when subjected to constant chemical conditions. Never allow a column to dry out and ensure the column is sealed well at all times.</p> <p>Also protect eluents that have a weak buffer capacity (such as caustic soda eluents) from carbon dioxide.</p>
<i>CO₂</i>	Carbon dioxide from the air affects the carbonate/hydrogen carbonate balance in the eluent. The eluent becomes weaker over time. In order to prevent this, always outfit the eluent bottle with CO ₂ adsorber material (such as soda lime).
<i>Eluent bottles</i>	The eluents are usually placed directly on the IC system in special eluent bottles. The bottles must feature an adsorber tube in order to prevent moisture and carbon dioxide from getting into the eluent. The adsorber

tube is usually filled with molecular sieve. For sodium hydroxide and carbonate eluents, soda lime (a weak CO₂ adsorber) is used.

Degassing the eluent

In order to prevent bubbles from forming, we recommend degassing the produced eluent before using it in your IC system. To degas the eluent, create a vacuum for approximately ten minutes using a water-jet pump or an oil pump. Use an ultrasonic bath or work with an eluent degasser.

Filter

Problems that occur in IC systems are usually related to particles. These particles can be introduced from the following sources:

- Bacterial growth
- Unfiltered eluents
- The sample
- The rinsing solution and/or regeneration solution

Minimize this risk by using an aspiration filter (6.2821.090), an inline filter (6.2821.120) and a guard column. The filters are part of the basic equipment for Metrohm ion chromatographs and are included in the scope of delivery. We also recommend changing the filters regularly.

Filtering the eluent

All eluents have to be microfiltered (0.45 µm) immediately before use.

Particles

All solutions, samples, regeneration solutions, water and eluents must be free of particles. Particles clog separation columns over time (column pressure increases). Be especially conscious of ensuring that there are no particles present when producing eluents. The eluent continuously flows through the column at a rate of 500 to 1000 mL per workday compared to about 0.5 mL of the sample solution. Filter or dialyze your sample automatically with one of the Metrohm Inline Sample Preparation techniques (MISP).

Sample preparation cartridges

Sample preparation cartridges are used to prepare critical samples that must not be injected directly into the separation column. They perform tasks such as removing organic contaminants or neutralizing heavily alkaline or acidic samples. Sample preparation cartridges are consumables that generally cannot be regenerated. Sample preparation cartridges do not replace the guard columns, which should always be used with each separation column. As an alternative to sample preparation cartridges, Metrohm Inline Sample Preparation techniques (MISP) can be used, such as for neutralizing alkaline samples.

Pulsation absorber

We recommend using a pulsation absorber (6.2620.150). Polymethacrylate columns and polyvinyl alcohol columns in particular must be protected from the brief pressure surges that inevitably occur when switching the valves.



<i>Mechanical stress</i>	Mechanical loads on the column should be avoided. For example, the column impacting a hard surface can cause a break or gap in the column packing (separation phase material); this affects the chromatography results. The column would be irreparably damaged as a result.
<i>Regenerating separation columns</i>	<p>If separation columns are operated with clean eluents and filled with samples free of particles, you can expect the column to have a long service life. This means regenerating the column is not required and, after a multitude of injections, no longer possible.</p> <p>If the pressure in the column increases unexpectedly despite this or if the separating efficiency decreases, the regeneration steps specified for every column can be carried out. Generally, it is important to keep in mind that the regeneration takes place outside the analytical line. Connect the separation column to the pump directly. Route the regeneration solution through the column directly into a waste container. Before reinstalling the separation column, it must be properly rinsed with fresh eluent.</p>
<i>Shutting down the ion chromatograph</i>	<p>If you will not be working with the ion chromatograph for a prolonged period (> 1 week), we recommend removing the separation column and sealing it with the stoppers provided. Rinse the ion chromatograph with methanol/water (1:4). Store the separation column in the medium indicated on the column leaflet and, ideally, at a temperature between 4 and 8 °C if not specified otherwise.</p> <p>When you return the instrument to operation, rinse the ion chromatograph with fresh eluent. Bring the separation column back to ambient temperature before you install it. Then increase the temperature if necessary.</p>
<i>Fun</i>	Ion chromatography should be fun and should not stress you out. Metrohm puts all its work into ensuring you can work reliably with your IC systems with minimal maintenance, servicing and costs. Metrosep separation columns embody the attributes of quality, long service life and excellent results.
<i>Environmental protection</i>	A significant advantage of ion chromatography is that most of the work involves aqueous media. As a result, the chemicals used in ion chromatography are largely non-toxic and do not impact the environment. However, if you are working with acids, bases, organic solvents or heavy metal standards, dispose of them properly after use.
<i>Guard columns</i>	Guard columns are used to protect separation columns. We strongly recommend their use. They normally contain the same stationary phase also used in the separation columns, but in significantly reduced quantity to avoid impacting the chromatography. Guard columns remove critical con-

contaminants that could react with column material; they also effectively remove particles and bacterial contaminants.

Replace the guard column in the following cases:

- If the backpressure in the system increases
- If the chromatography results deteriorate

We recommend using 3 to 4 guard columns over the service life of the separation column.

Guard columns are available for all Metrosep separation columns.

Water quality

Aqueous media are mostly used in work involving ion chromatography. This means that water quality is a critical factor for good chromatography. If the water quality is inadequate, the results will be as well. In addition, there is a risk of damaging instruments and separation columns when using water with inadequate quality. The ultrapure water being used should have a specific resistance greater than 18.2 M Ω ·cm and should be free of particles. Therefore, we recommend filtering the water using a 0.45 μ m filter and treating it with UV light. Modern ultrapure water systems for laboratory use ensure this level of water quality (Type I).



3 Eluent production

We recommend selecting a high level of purity for chemicals for both standard production and eluent production.

3.1 Chemicals

Recommended chemicals

- Sodium carbonate
Merck order number: 1.06393.1000
- Sodium hydrogen carbonate
Merck order number: 1.06329.1000
- Ultrapure water of type I (see ASTM D1193)
Resistance > 18 M Ω ·cm (25 °C)
TOC < 10 μ g/L

3.2 Production of standard eluent

To produce 2 L of the standard eluent with 1.8 mmol/L sodium carbonate and 1.7 mmol/L sodium hydrogen carbonate, the following steps must be carried out:

Producing 2 L of standard eluent

Required accessories

- Eluent bottle
- Cap equipped with CO₂ adsorber
- Ultrapure water
- Sodium carbonate
- Sodium hydrogen carbonate

- 1** Pre-rinse the eluent bottle with ultrapure water several times.
- 2** Fill 2 L of ultrapure water into the eluent bottle.
- 3** Use the eluent degasser. If no eluent degasser is available, degas the ultrapure water for 5 to 10 minutes using a vacuum pump.

Degassing avoids problems with air bubbles in the high-pressure pump.
- 4** Weigh and add 381.6 mg of sodium carbonate and 285.6 mg of sodium hydrogen carbonate and then stir.

5 Rinse the column during 2 to 3 hours with the eluent.

This eluent (1.8 mmol/L of sodium carbonate and 1.7 mmol/L of sodium hydrogen carbonate) and sequential suppression can be used to achieve background conductivity of $< 1 \mu\text{S}/\text{cm}$. The noise is typically less than 0.2 nS/cm.

**NOTE**

The guard column may not be connected until after the instrument has already been put into operation once. The guard column and the separation column have to be replaced by a coupling (6.2744.040) until then.

Accessories

For this step, you need the following accessories:

- Guard column (suitable for separation column)

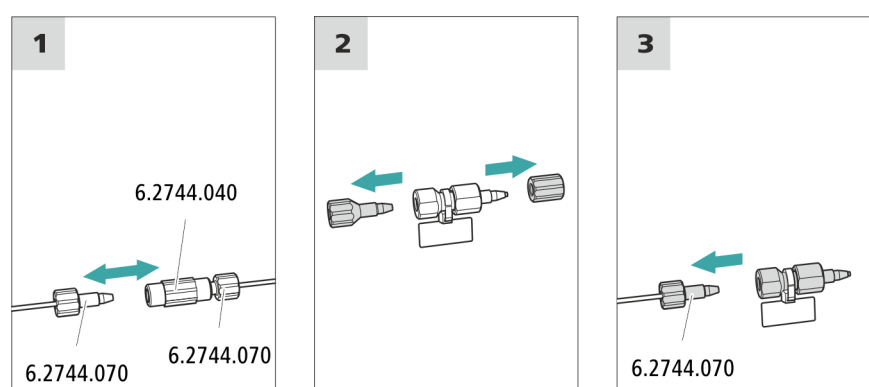
Connecting the guard column**1 Removing the coupling**

Remove the coupling (6.2744.040) installed between the column inlet capillary and the column outlet capillary for the initial start-up.

2 Preparing the guard column

- Remove the stopper and the sealing cap from the guard column.

3 Connecting the guard column**CAUTION**

When inserting the guard column, ensure that it is inserted correctly based on the marked flow direction (if specified).

- Fasten the inlet of the guard column to the column inlet capillary using a short pressure screw (6.2744.070).



- If the guard column is connected to the separation column using a connection capillary, fasten this connection capillary to the guard column outlet with a pressure screw.

Rinsing the guard column

1 Rinsing the guard column

- Place a beaker under the guard column's outlet.
- Start manual control in MagIC Net and select the high-pressure pump: **Manual ▶ Manual control ▶ Pump**
 - **Flow: in accordance with column leaflet**
 - **On**
- Rinse the guard column with eluent for approx. 5 minutes.
- Stop the high-pressure pump in the manual control in MagIC Net again: **Off**.

4.2 Connecting the separation column

The smart separation column (iColumn) is the heart of ion chromatographic analysis. It separates the different components according to their interactions with the column. Metrohm separation columns are equipped with a chip where their technical specifications and history (start-up, operating hours, injections etc) are stored.



NOTE

Information regarding which separation column is suitable for your application can be found in the **Metrohm Column Program**, the product information for the separation column or it can be obtained through your representative.

You can find product information for your separation column at <http://www.metrohm.com> in the Ion Chromatography product area.

A test chromatogram and a leaflet accompanies every column. Detailed information on special IC applications can be found in the corresponding "**Application Bulletins**" or "**Application Notes**". You can find these online at <http://www.metrohm.com> in the Applications area or request them from your responsible Metrohm representative free of charge.

**CAUTION**

New separation columns are filled with a solution and sealed with stoppers on both sides. Before inserting the column, ensure that this solution can be mixed with the eluent being used (follow the information provided by the manufacturer).

**NOTE**

Connect the separation column only after the initial start-up of the instrument. Until that point, insert a coupling (6.2744.040) instead of the guard column and separation column.

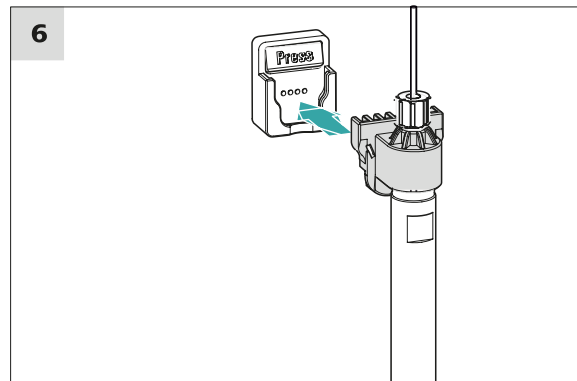
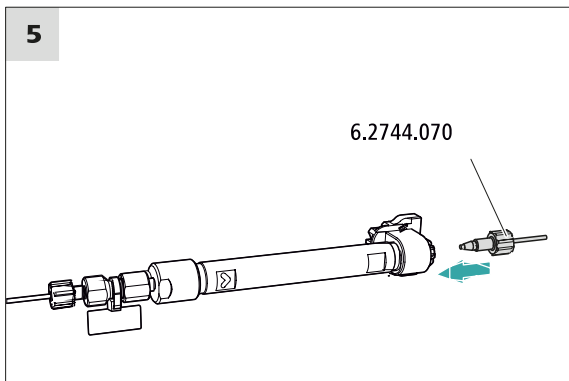
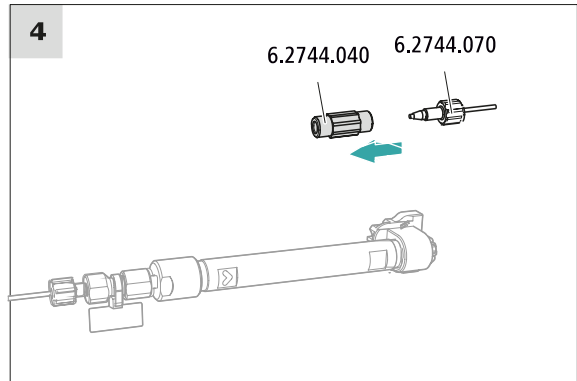
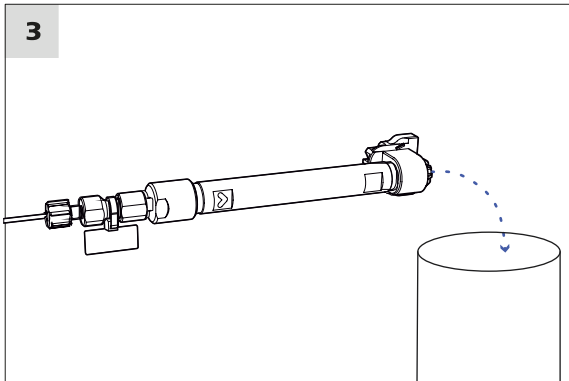
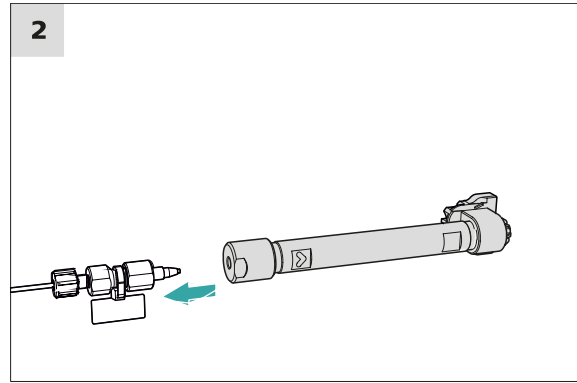
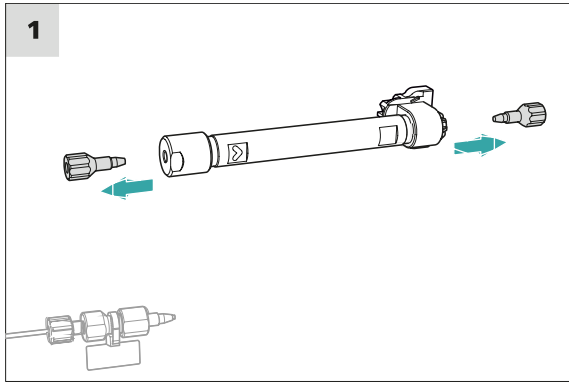

Connecting the separation column

1 Removing the stoppers

- Remove the stoppers from the separation column.

2 Installing the inlet of the separation column



CAUTION

When inserting the column, ensure that it is inserted correctly based on the marked flow direction.

There are three options:

- Attach the column inlet directly onto the guard column or,
- if the guard column is connected to the separation column using a connection capillary: Connect the column inlet to the guard column outlet capillary using a PEEK pressure screw (6.2744.070) or,
- if no guard column is used (not recommended): Connect the column inlet capillary to the inlet of the separation column using a short pressure screw (6.2744.070).

3 Rinsing the separation column

- Place a beaker under the outlet of the separation column.
- Start manual control in MagIC Net and select the high-pressure pump: **Manual ▶ Manual control ▶ Pump**
 - **Flow:** Increase gradually up to the flow rate recommended in the column leaflet.
 - **On**
- Rinse the separation column with eluent for approx. 10 minutes.
- Stop the high-pressure pump in the manual control in MagIC Net again: **Off**.

4 Removing the coupling

- Remove the coupling (6.2744.040) from the column outlet capillary.

5 Installing the outlet of the separation column

- Fasten the column outlet capillary to the column outlet using a short PEEK pressure screw (6.2744.070).

6 Inserting the separation column

- Insert the separation column with the chip into the column holder until you hear it snap in place.

The separation column is now detected by MagIC Net.

- Visually inspect whether all capillaries and their connections from the high-pressure pump to the detector are leak-tight. If eluent is leaking out anywhere, tighten the corresponding pressure screw further, or loosen the pressure screw, check the end of the capillary and shorten it using the capillary cutter if necessary and retighten the pressure screw.

4 Conditioning the system

Continue rinsing the system with eluent until the desired stability level for the baseline has been attained .

The instrument is now ready for measuring samples.



5 Applications

5.1 Standard chromatogram

4-mm column

Column: Metrosep A Supp 4 - 250/4.0

Sample preparation: -

Detection: Conductivity

Suppression: Chemical suppression with MSM

Temperature: 25 °C

Flow rate: 1.0 mL/min

Loop: 20 µL

Eluent: 1.8 mmol/L sodium carbonate, 1.7 mmol/L sodium hydrogen carbonate

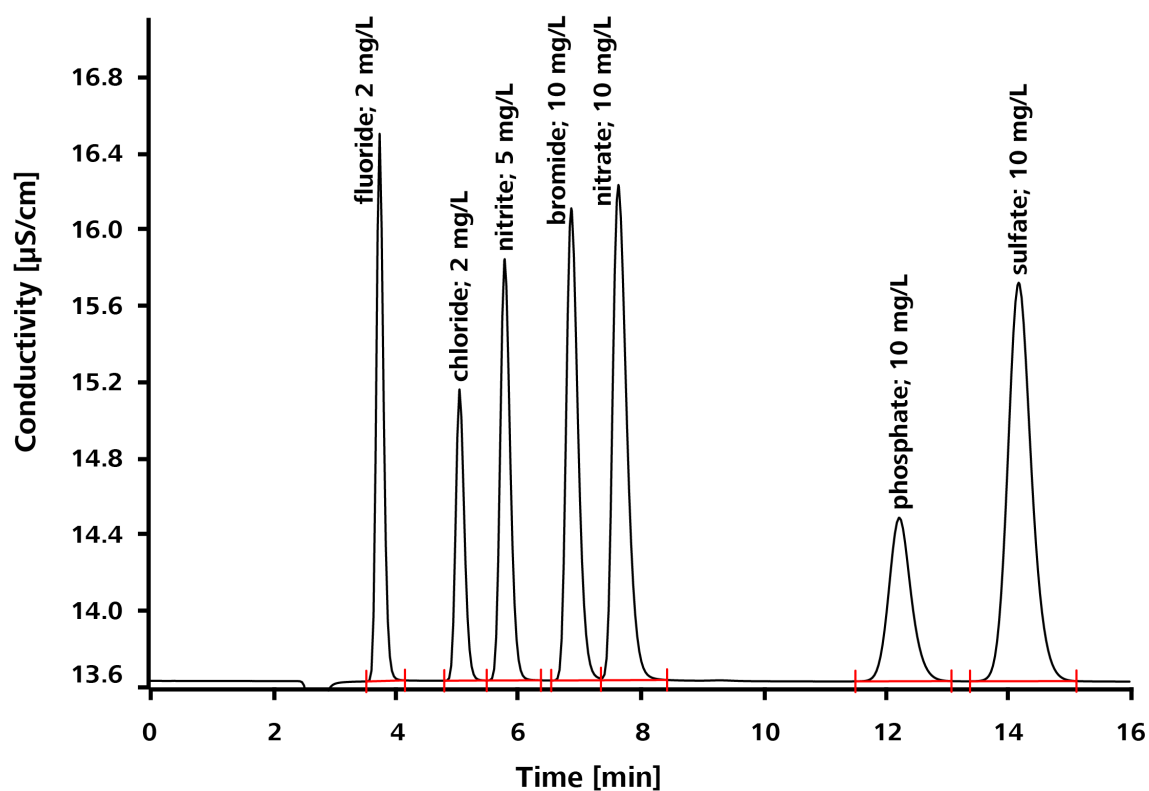

2-mm column

Column: Metrosep A Supp 4 - 250/2.0

Sample preparation: -

Detection: Conductivity

Suppression: Chemical suppression with MSM-LC

Temperature: 25 °C

Flow rate: 0.25 mL/min

Loop: 10 µL

Eluent: 1.8 mmol/L sodium carbonate, 1.7 mmol/L sodium hydrogen carbonate

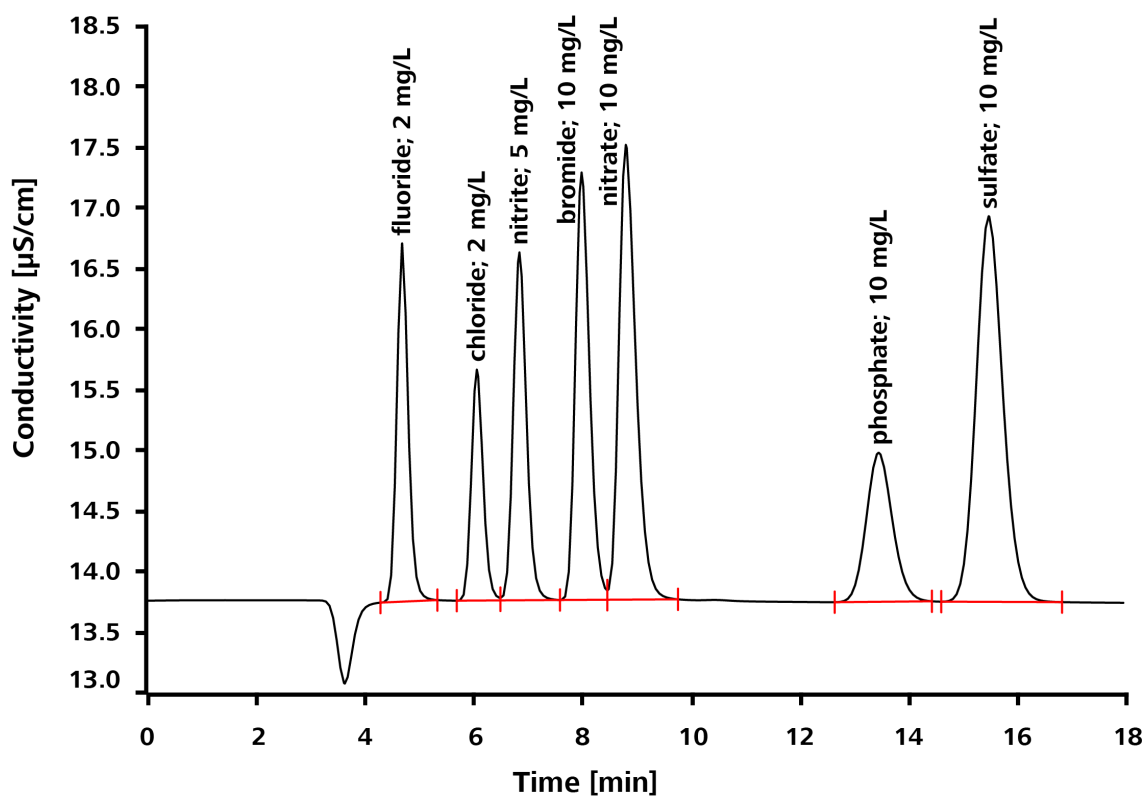



5.2 Effects of temperature

Column: Metrosep A Supp 4 - 250/4.0

Sample preparation: -

Detection: Conductivity

Suppression: Sequential suppression with MSM and MCS

Temperature: 20 to 60 °C

Flow rate: 1.0 mL/min

Loop: 20 μ L

Eluent: 1.8 mmol/L sodium carbonate, 1.7 mmol/L sodium hydrogen carbonate

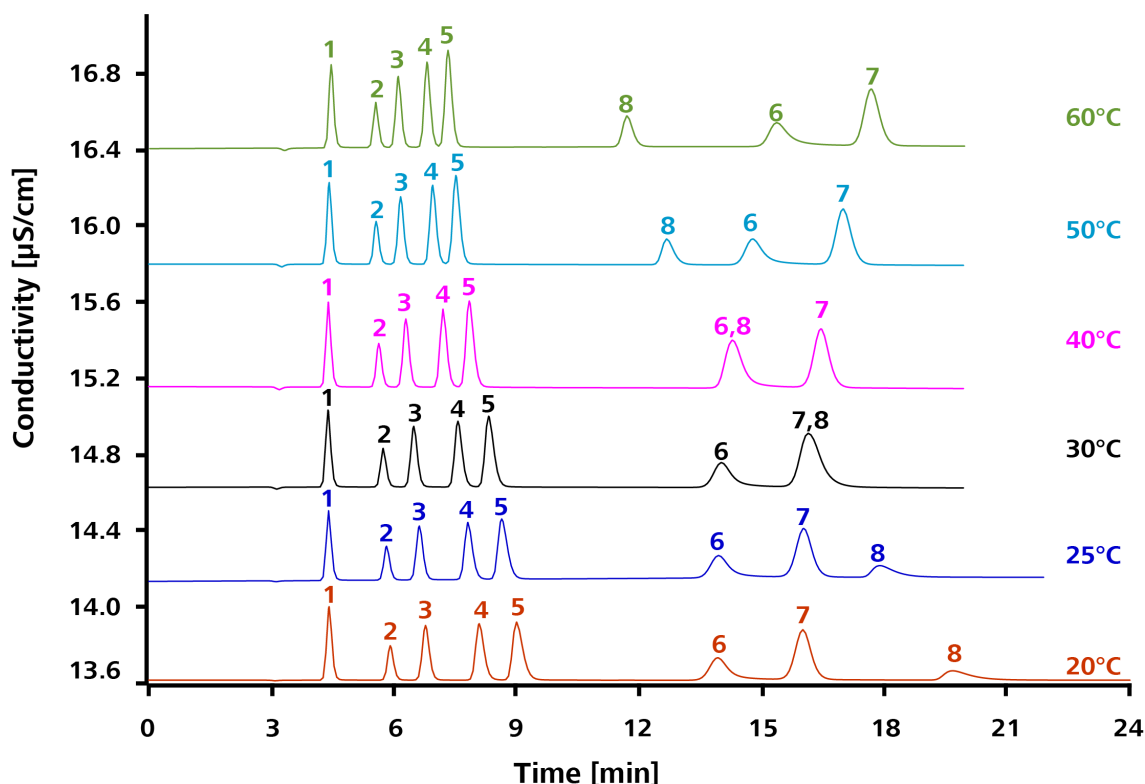

An increase in temperature results in slightly shorter retention times of the monovalent anions. The retention time of iodide, however, is drastically reduced when increasing the temperature. Iodide co-elutes with sulfate at 30 °C and with phosphate at 40 °C. At a higher temperature, phosphate and Sulfate elute later.



	Metrosep A Supp 4 - 250/4.0	mg/L
1	Fluoride	2
2	Chloride	2
3	Nitrite	5
4	Bromide	10
5	Nitrate	10
6	Phosphate	10
7	Sulfate	10
8	Iodide	10

5.3 Eluent flow rate variation

Column: Metrosep A Supp 4 - 250/4.0

Sample preparation: -

Detection: Conductivity

Suppression: Sequential suppression with MSM and MCS

Temperature: 25 °C

Flow rate: 1.0 to 2.0 mL/min

Loop: 20 µL

Eluent: 1.8 mmol/L sodium carbonate, 1.7 mmol/L sodium hydrogen carbonate

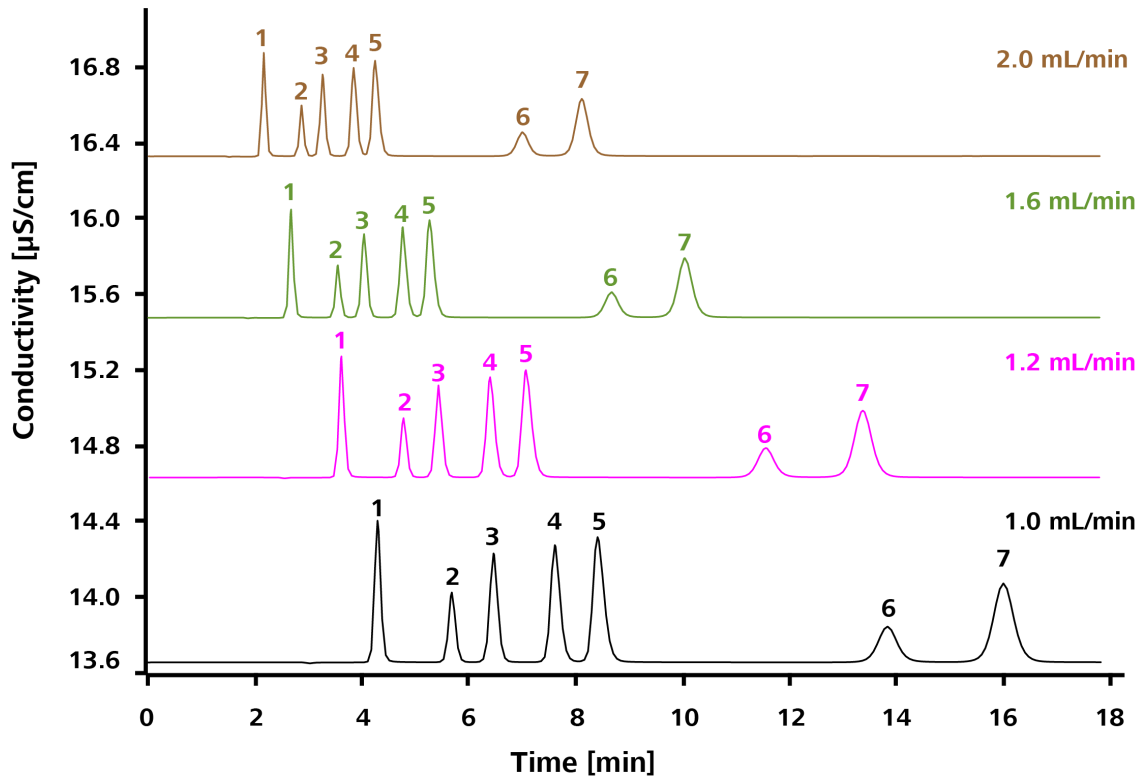

The retention times of all standard ions decrease with increasing flow rate. Fluoride approaches the injection peak.

Metrosep A Supp 4 - 250/4.0		mg/L
1	Fluoride	2
2	Chloride	2
3	Nitrite	5
4	Bromide	10
5	Nitrate	10
6	Phosphate	10
7	Sulfate	10

5.4 Variation of the eluent

Variation with constant sodium carbonate / sodium hydrogen carbonate ratio

Column: Metrosep A Supp 4 - 250/4.0

Sample preparation: -

Detection: Conductivity

Suppression: Sequential suppression with MSM and MCS

Temperature: 25 °C

Loop: 20 µL

Flow rate: 1.0 mL/min

Eluent: A) 1 mmol/L sodium carbonate, 1 mmol/L sodium hydrogen carbonate

B) 2 mmol/L sodium carbonate, 2 mmol/L sodium hydrogen carbonate

C) 3 mmol/L sodium carbonate, 3 mmol/L sodium hydrogen carbonate

D) 4 mmol/L sodium carbonate, 4 mmol/L sodium hydrogen carbonate

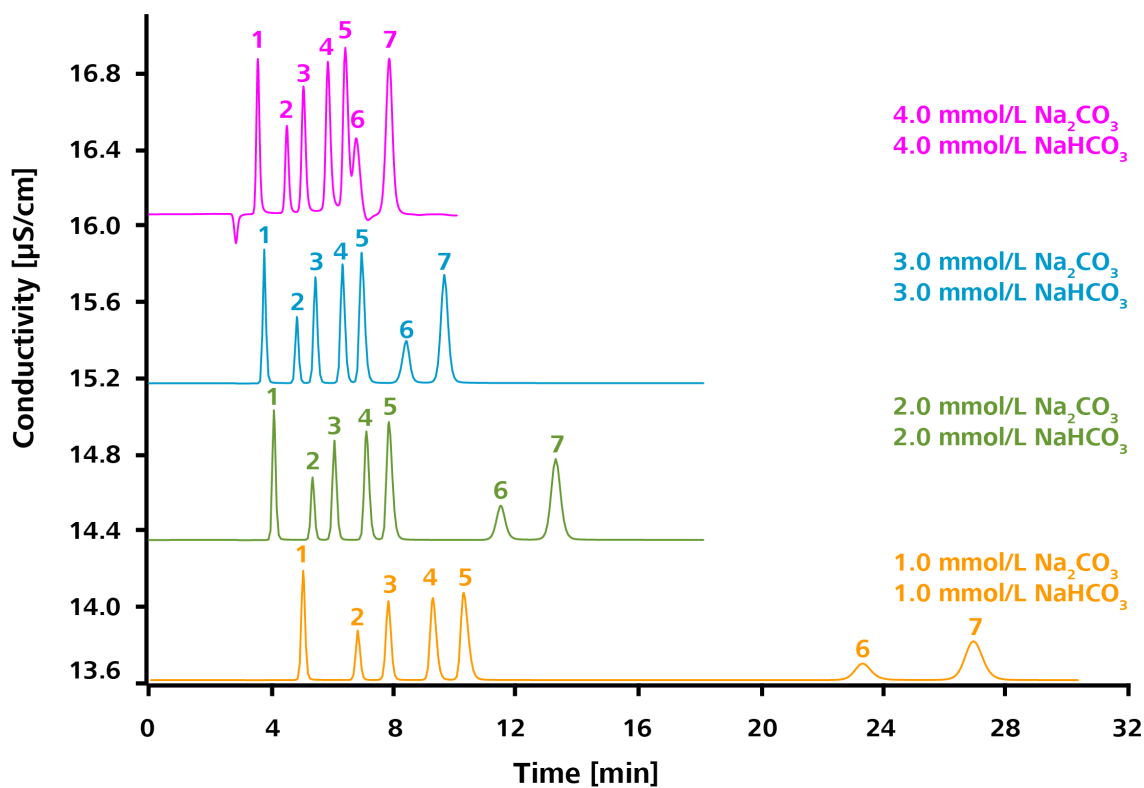



The retention times become shorter with increasing sodium carbonate / sodium hydrogen carbonate concentration. Those for the polyvalent anions phosphate and sulfate are strongly shortened in particular. With 4 mmol/L sodium carbonate, 4 mmol/L sodium hydrogen carbonate, phosphate co-elutes with nitrate.

Metrosep A Supp 4 - 250/4.0		mg/L
1	Fluoride	2
2	Chloride	2
3	Nitrite	5
4	Bromide	10
5	Nitrate	10
6	Phosphate	10
7	Sulfate	10

Variation of sodium hydrogen carbonate with constant sodium carbonate

<i>Column:</i>	Metrosep A Supp 4 - 250/4.0
<i>Sample preparation:</i>	-
<i>Detection:</i>	Conductivity
<i>Suppression:</i>	Sequential suppression with MSM and MCS
<i>Temperature:</i>	25 °C
<i>Loop:</i>	20 µL
<i>Flow rate:</i>	1.0 mL/min
<i>Eluent:</i>	A) 1.8 mmol/L sodium carbonate, 1 mmol/L sodium hydrogen carbonate B) 1.8 mmol/L sodium carbonate, 2 mmol/L sodium hydrogen carbonate C) 1.8 mmol/L sodium carbonate, 3 mmol/L sodium hydrogen carbonate D) 1.8 mmol/L sodium carbonate, 4 mmol/L sodium hydrogen carbonate

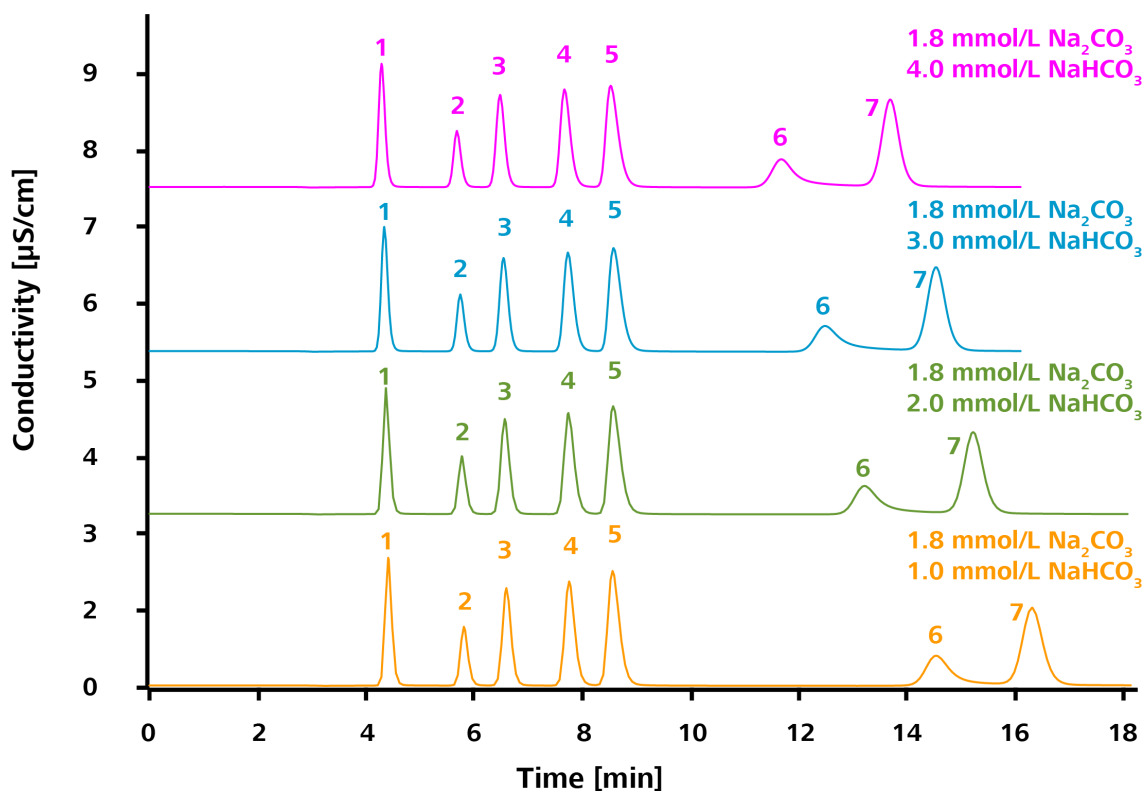

When the sodium hydrogen carbonate concentration is increased, the retention time of the monovalent anions decreases only slightly. For phosphate and sulfate, however, the retention time decreases evidently.

	Metrosep A Supp 4 - 250/4.0	mg/L
1	Fluoride	2
2	Chloride	2
3	Nitrite	5
4	Bromide	10
5	Nitrate	10
6	Phosphate	10
7	Sulfate	10

Variation of sodium carbonate with constant sodium hydrogen carbonate

Column: Metrosep A Supp 4 - 250/4.0

Sample preparation: -

Detection: Conductivity

Suppression: Sequential suppression with MSM and MCS

5.4 Variation of the eluent



Temperature: 25 °C

Loop: 20 µL

Flow rate: 1.0 mL/min

Eluent: A) 1 mmol/L sodium carbonate, 1.7 mmol/L sodium hydrogen carbonate
 B) 2 mmol/L sodium carbonate, 1.7 mmol/L sodium hydrogen carbonate
 C) 3 mmol/L sodium carbonate, 1.7 mmol/L sodium hydrogen carbonate
 D) 4 mmol/L sodium carbonate, 1.7 mmol/L sodium hydrogen carbonate

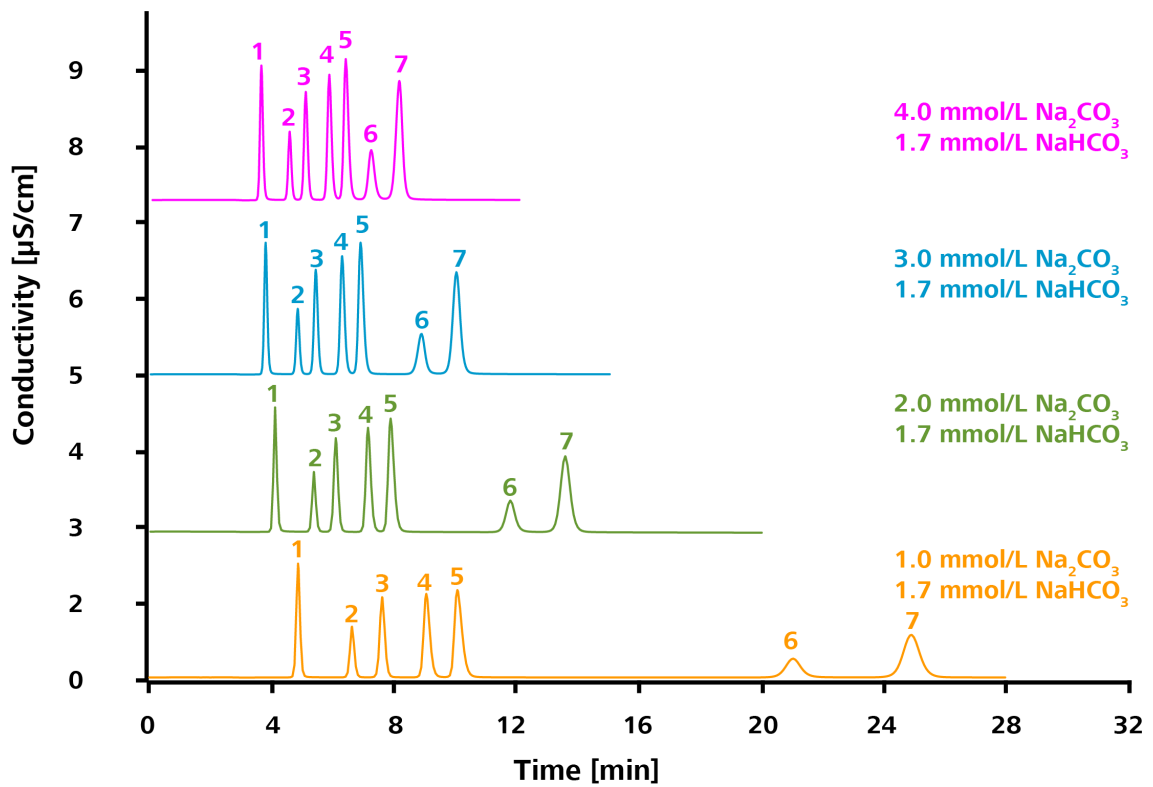

The retention times of phosphate and sulfate can be shortened disproportionately by increasing the sodium carbonate concentration.

Metrosep A Supp 4 - 250/4.0		mg/L
1	Fluoride	2
2	Chloride	2
3	Nitrite	5
4	Bromide	10
5	Nitrate	10
6	Phosphate	10
7	Sulfate	10

Variation of organic modifier: Acetone

Column:	Metrosep A Supp 4 - 250/4.0
Sample preparation:	-
Detection:	Conductivity
Suppression:	Sequential suppression with MSM and MCS
Temperature:	25 °C
Loop:	20 µL
Flow rate:	1.0 mL/min
Eluent:	<p>A) 1.8 mmol/L sodium carbonate, 1.7 mmol/L sodium hydrogen carbonate, 0% acetone</p> <p>B) 1.8 mmol/L sodium carbonate, 1.7 mmol/L sodium hydrogen carbonate, 10% acetone</p> <p>C) 1.8 mmol/L sodium carbonate, 1.7 mmol/L sodium hydrogen carbonate, 20% acetone</p> <p>D) 1.8 mmol/L sodium carbonate, 1.7 mmol/L sodium hydrogen carbonate, 30% acetone</p>

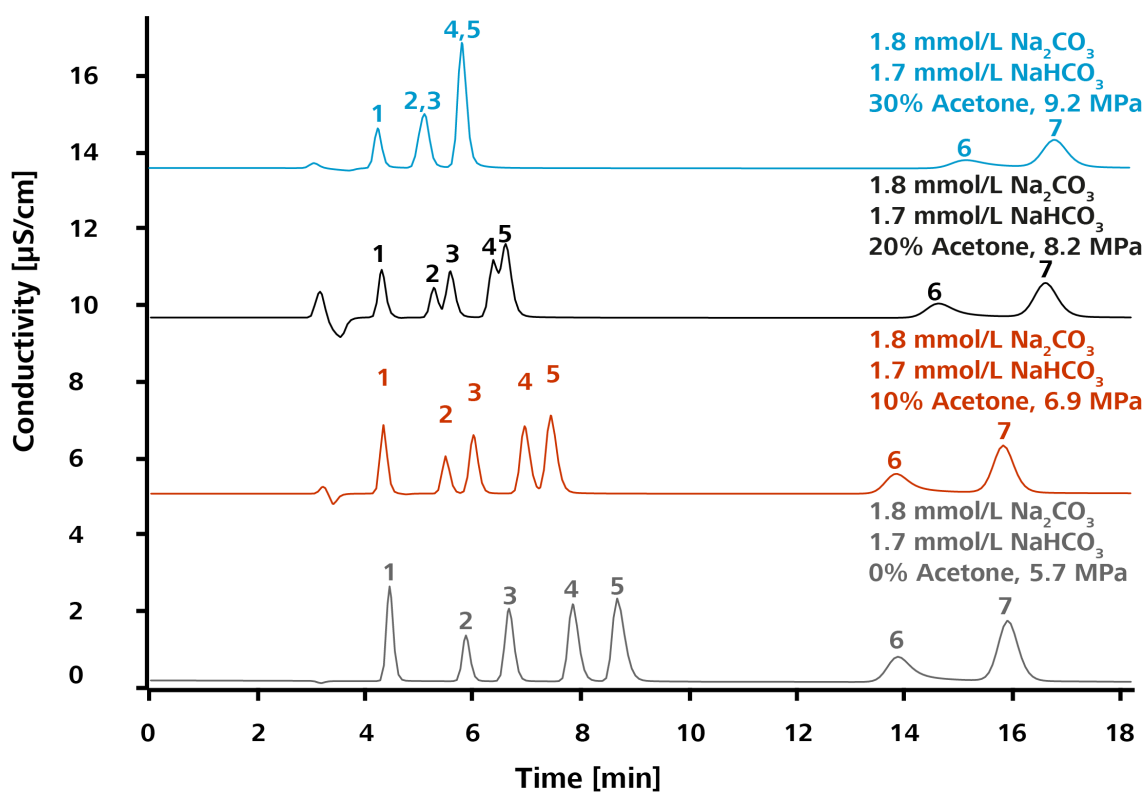



The backpressure increases gradually as acetone content increases. The pressure is 6.9 MPa at 10%. The retention time of phosphate and sulfate increases when adding acetone. The monovalent anions elute earlier. From 20% acetone content, chloride and nitrite as well as bromide and nitrate co-elute.

Metrosep A Supp 4 - 250/4.0		mg/L
1	Fluoride	2
2	Chloride	2
3	Nitrite	5
4	Bromide	10
5	Nitrate	10
6	Phosphate	10
7	Sulfate	10

Variation of organic modifier: Methanol

<i>Column:</i>	Metrosep A Supp 4 - 250/4.0
<i>Sample preparation:</i>	-
<i>Detection:</i>	Conductivity
<i>Suppression:</i>	Sequential suppression with MSM and MCS
<i>Temperature:</i>	25 °C
<i>Loop:</i>	20 µL
<i>Flow rate:</i>	1.0 mL/min
<i>Eluent:</i>	<p>A) 1.8 mmol/L sodium carbonate, 1.7 mmol/L sodium hydrogen carbonate, 0% methanol</p> <p>B) 1.8 mmol/L sodium carbonate, 1.7 mmol/L sodium hydrogen carbonate, 10% methanol</p> <p>C) 1.8 mmol/L sodium carbonate, 1.7 mmol/L sodium hydrogen carbonate, 20% methanol</p> <p>D) 1.8 mmol/L sodium carbonate, 1.7 mmol/L sodium hydrogen carbonate, 30% methanol</p>

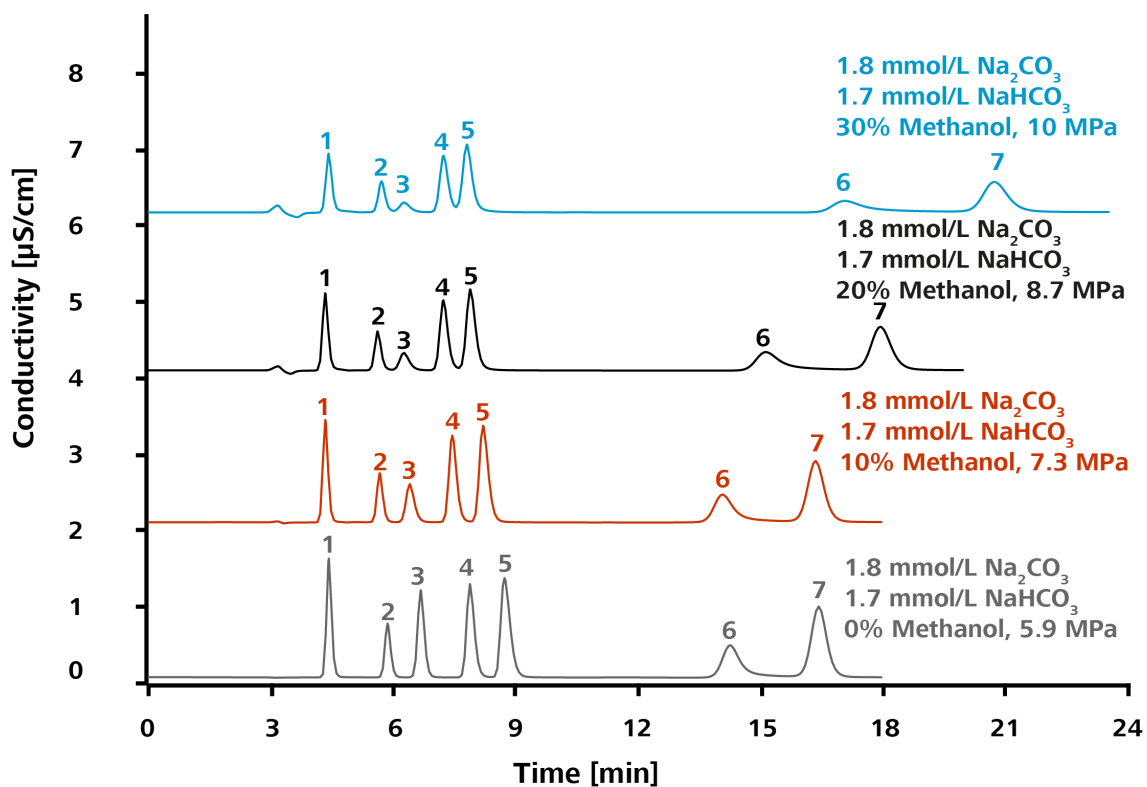

The backpressure increases gradually as methanol content increases. The pressure is 7.3 MPa at 10%. The retention time of phosphate and sulfate increases when adding methanol. The retention time of the monovalent anions decreases only slightly. Increasing the methanol content results in a weaker detection of nitrite. An interference peak forms at the injection peak with increasing solvent content.

Metrosep A Supp 4 - 250/4.0		mg/L
1	Fluoride	2
2	Chloride	2
3	Nitrite	5
4	Bromide	10
5	Nitrate	10
6	Phosphate	10
7	Sulfate	10

Variation of organic modifier: Acetonitrile

Column: Metrosep A Supp 4 - 250/4.0

Sample preparation: -

Detection: Conductivity

<i>Suppression:</i>	Sequential suppression with MSM and MCS
<i>Temperature:</i>	25 °C
<i>Loop:</i>	20 µL
<i>Flow rate:</i>	1.0 mL/min
<i>Eluent:</i>	<p>A) 1.8 mmol/L sodium carbonate, 1.7 mmol/L sodium hydrogen carbonate, 0% acetonitrile</p> <p>B) 1.8 mmol/L sodium carbonate, 1.7 mmol/L sodium hydrogen carbonate, 10% acetonitrile</p> <p>C) 1.8 mmol/L sodium carbonate, 1.7 mmol/L sodium hydrogen carbonate, 20% acetonitrile</p> <p>D) 1.8 mmol/L sodium carbonate, 1.7 mmol/L sodium hydrogen carbonate, 30% acetonitrile</p>

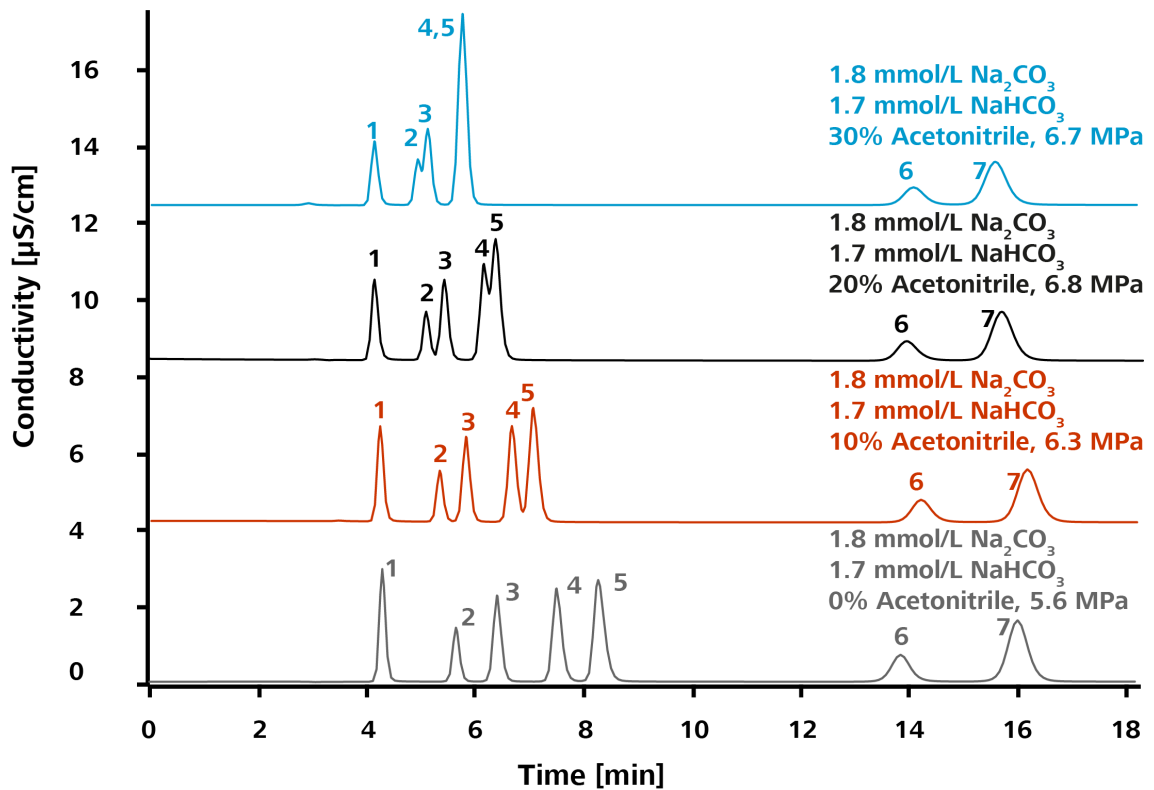

The pressure is 6.3 MPa at 10%. The monovalent anions elute earlier. At 20% acetonitrile content, chloride and nitrite as well as bromide and nitrate co-elute. Acetonitrile as organic modifier generates the smallest backpressure.

	Metrosep A Supp 4 - 250/4.0	mg/L
1	Fluoride	2
2	Chloride	2
3	Nitrite	5
4	Bromide	10
5	Nitrate	10
6	Phosphate	10
7	Sulfate	10

5.5 Wastewater analysis Herisau waste treatment plant

Column: Metrosep A Supp 4 - 250/2.0

Sample preparation: The sample was diluted at a 1:10 ratio and filtered with a 0.2- μ m particle filter.

Detection: Conductivity

Suppression: Sequential suppression with MSM-LC and MCS

Temperature: 25 °C

Loop: 20 μ L

Flow rate: 0.25 mL/min

Eluent: 1.8 mmol/L sodium carbonate, 1.7 mmol/L sodium hydrogen carbonate

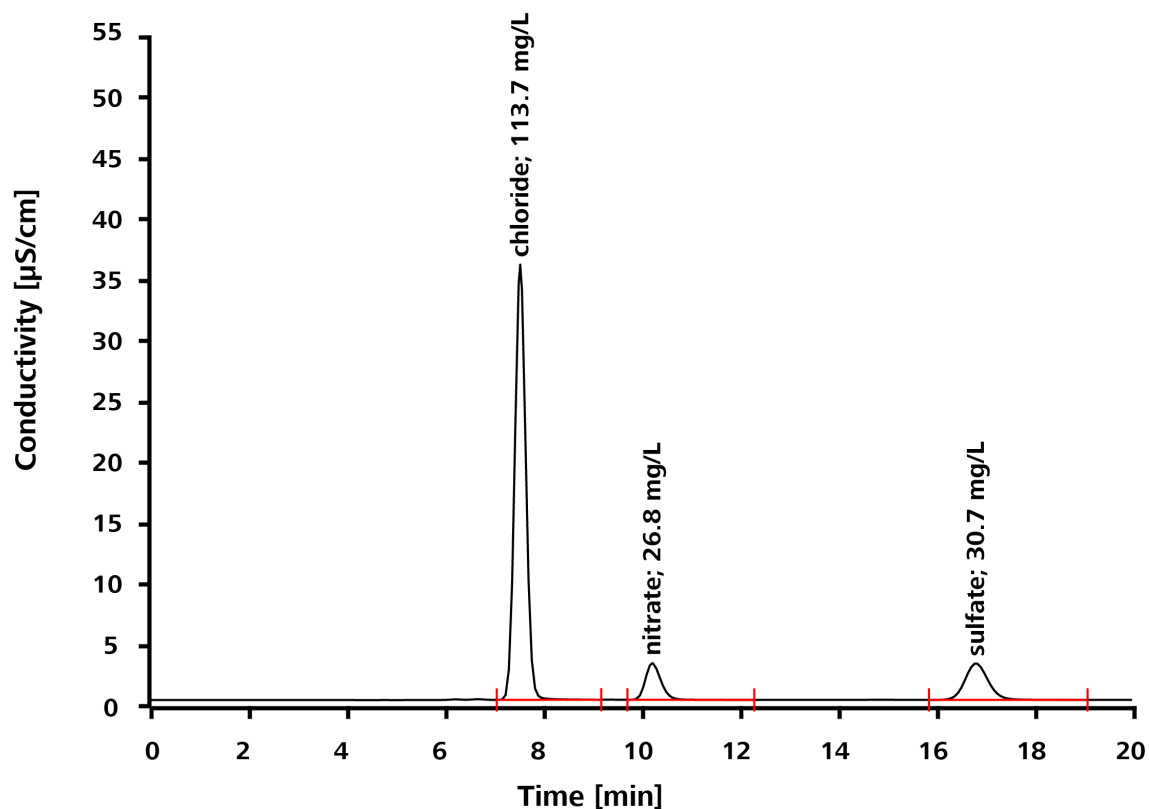

5.6 Organic acids

Column: Metrosep A Supp 4 - 250/4.0

Sample preparation: –

Detection: Conductivity

Suppression: Sequential suppression with MSM and MCS

Temperature: 25 °C

Loop: 20 μL

Flow rate: 1.0 mL/min

Eluent: 1.8 mmol/L sodium carbonate, 1.7 mmol/L sodium hydrogen carbonate

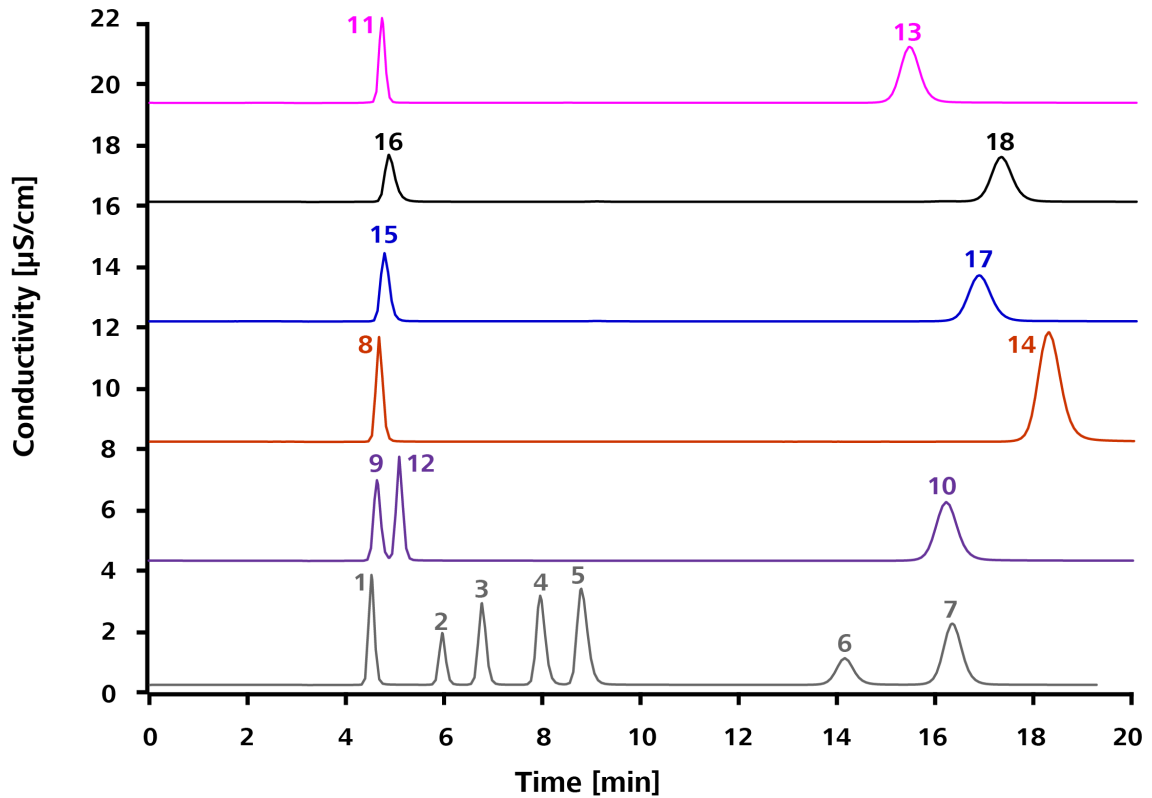

MSA and formate show a good separation with fluoride. Oxalate shows a good separation with sulfate. The separation of formate/acetate is not sufficient.

	Metrosep A Supp 4 - 250/4.0	mg/L
1	Fluoride	2
2	Chloride	2
3	Nitrite	5
4	Bromide	10
5	Nitrate	10
6	Phosphate	10
7	Sulfate	10
8	Glycolate	10
9	Lactate	10
10	Malate	20
11	Formate	5
12	MSA	10
13	Tartrate	20
14	Oxalate	20



	Metrosep A Supp 4 - 250/4.0	mg/L
15	Acetate	10
16	Propionate	10
17	Succinate	20
18	Maleate	20

5.7 Determination of fluoride, chloride, nitrite, nitrate and sulfate in mineral water

Column: Metrosep A Supp 4 - 250/4.0

Sample preparation: The sample was diluted at a 1:2 ratio with ultrapure water.

Detection: Conductivity

Suppression: Chemical suppression with MSM

Temperature: 25 °C

Loop: 20 µL

Flow rate: 1.0 mL/min

Eluent: 4.0 mmol/L sodium carbonate, 1.0 mmol/L sodium hydrogen carbonate

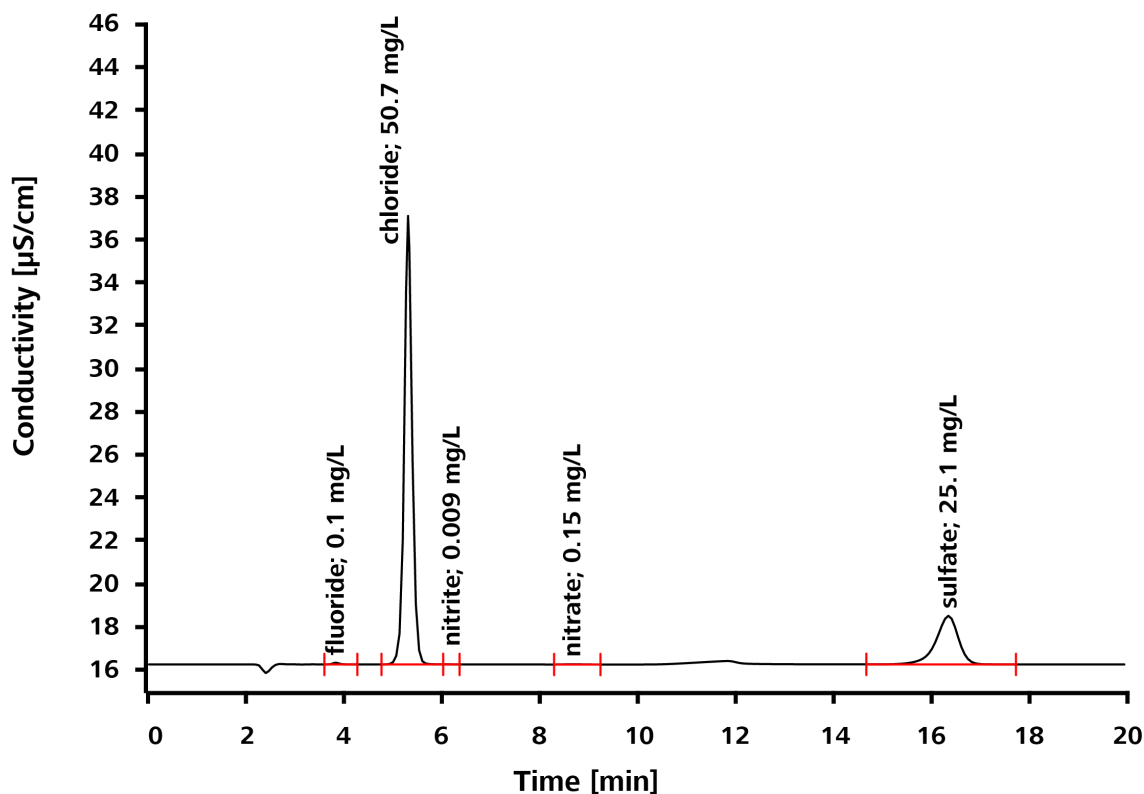

5.8 Determination of chloride in system health check solution in heating systems

<i>Column:</i>	Metrosep A Supp 4 - 250/4.0 with Metrosep RP 2 Guard/3.5
<i>Sample preparation:</i>	Metrohm Inline Ultrafiltration
<i>Detection:</i>	Conductivity
<i>Suppression:</i>	Sequential suppression with MSM and MCS
<i>Temperature:</i>	25 °C
<i>Loop:</i>	1.5 µL
<i>Flow rate:</i>	1.25 mL/min
<i>Eluent:</i>	2.4 mmol/L sodium carbonate, 2.3 mmol/L sodium hydrogen carbonate, 15% acetone

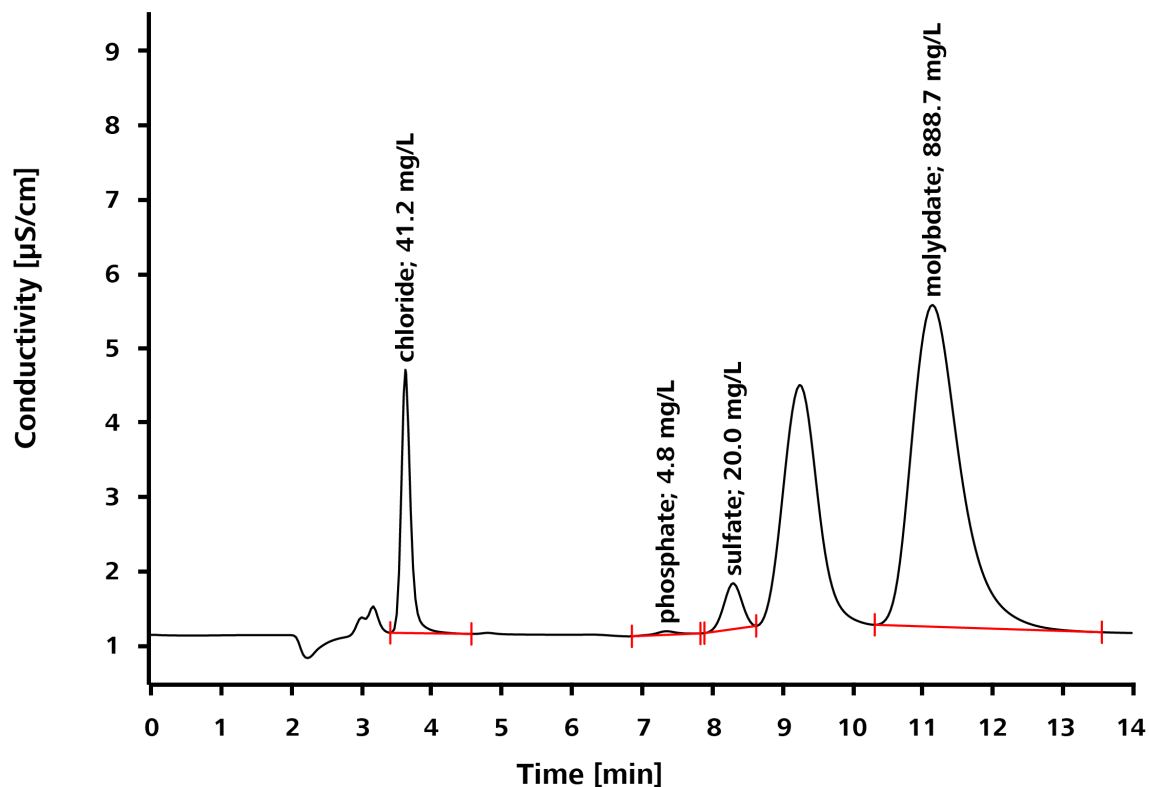

Molybdate protects the heating system and is added as a modifier. It can be quantified directly with the standard anions in a determination.

5.9 Non-suppressed conductivity determination of hydroxylamine disulfonate

Column: Metrosep A Supp 4 - 250/4.0

Sample preparation: Filtration with a 0.2- μm particle filter

Detection: Conductivity

Suppression: –

Temperature: 25 °C

Loop: 50 μL

Flow rate: 1.5 mL/min

Eluent: 10 mmol/L phthalic acid, 2% acetone (pH value with TRIS buffer set to 7.6)

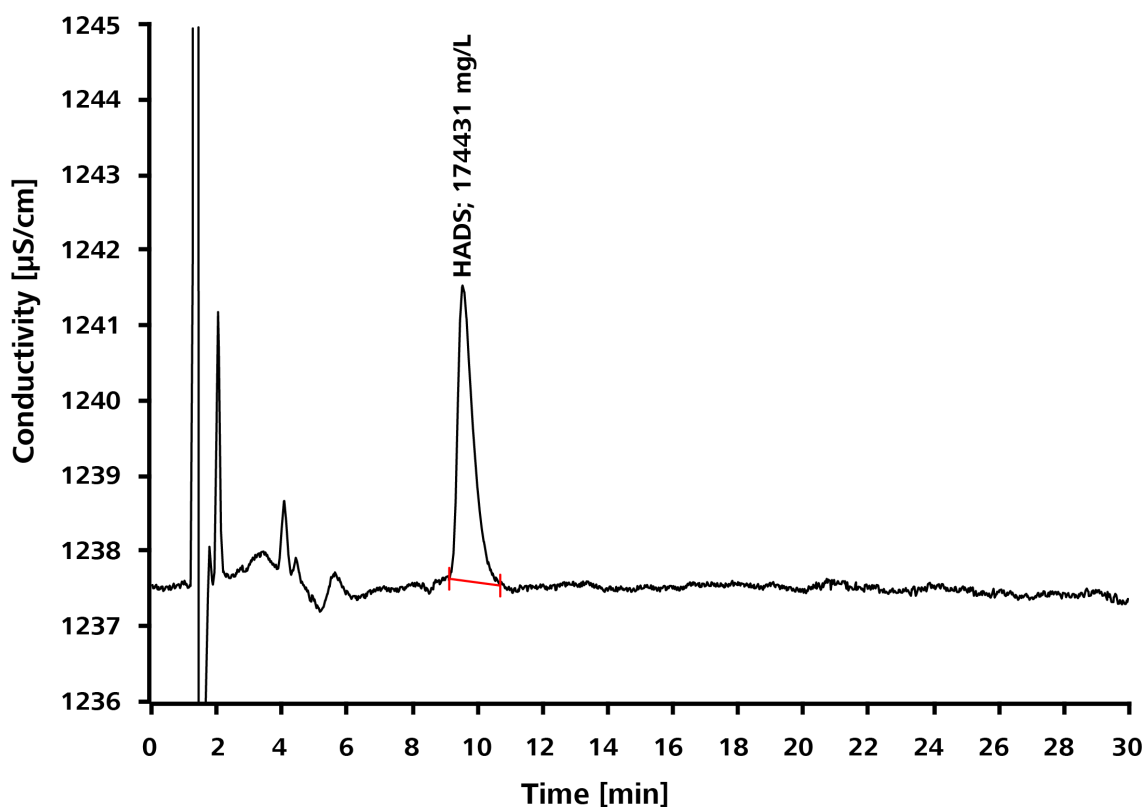

In these measuring conditions, all standard anions elute under 3 minutes and do not disrupt the determination.

5.10 Determination of phosphate and citrate in blood clotting solutions

<i>Column:</i>	Metrosep A Supp 4 - 250/4.0
<i>Sample preparation:</i>	Filtration with a 0.2- μm particle filter
<i>Detection:</i>	Conductivity
<i>Suppression:</i>	Sequential suppression with MSM and MCS
<i>Temperature:</i>	25 °C
<i>Loop:</i>	10 μL
<i>Flow rate:</i>	2.0 mL/min
<i>Eluent:</i>	20 mmol/L of sodium hydroxide

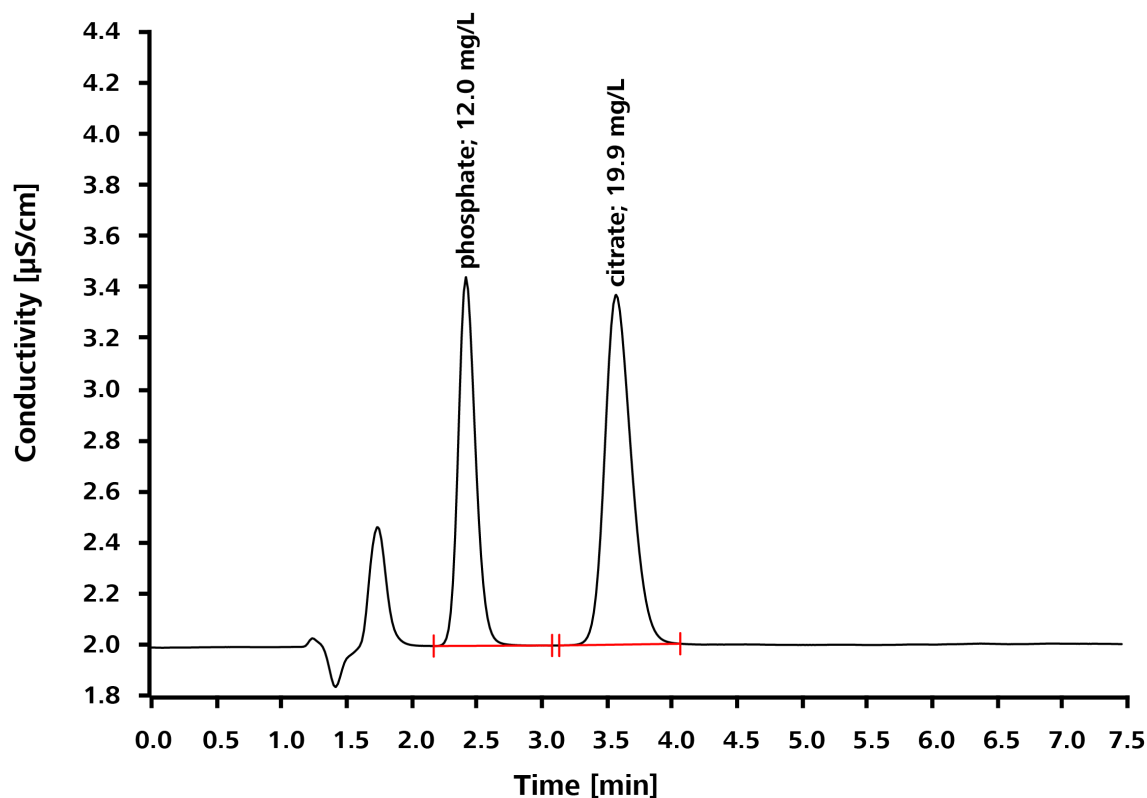

5.11 Determination of iodate, chloride, nitrate, sulfate and iodide using conductivity determination and MiPT

Column:	Metrosep A Supp 4 - 250/4.0
Sample preparation:	–
Detection:	Conductivity
Suppression:	Sequential suppression with MSM and MCS
Temperature:	25 °C
Loop:	5 μL with Metrohm intelligent Partial Loop Injection Technique (MiPT)
Flow rate:	1.0 mL/min
Eluent:	1.8 mmol/L sodium carbonate, 1.7 mmol/L sodium hydrogen carbonate

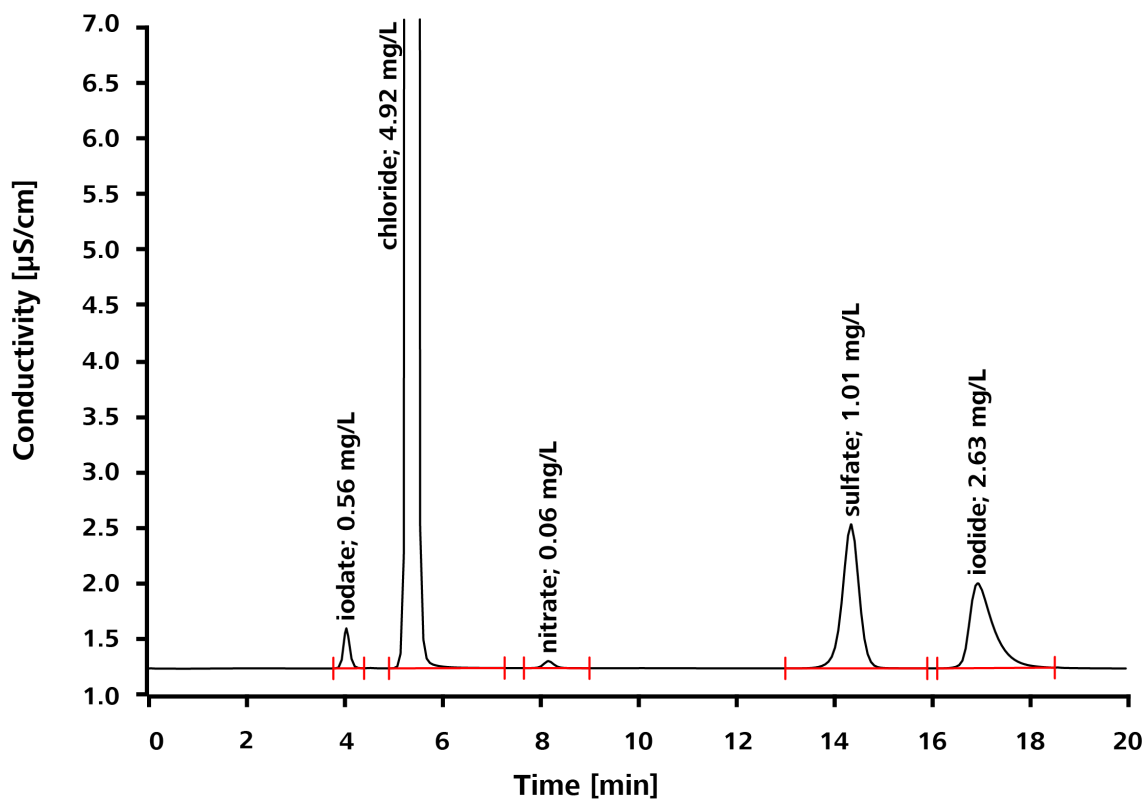

Fluoride elutes at the same retention time as iodate. If the sample contains fluoride, it is advisable to confirm the iodate with UV detection.

- Contamination with high-valence hydrophobic ions or organic contamination (see Table 6, page 41)

Table 5 Contamination with low-valence hydrophilic ions

Metrosep A Supp 4 - 250/4.0		Duration	Flow rate
1.	Rinse with ultrapure water	10 min	0.5 mL/min
2.	Rinse with 10x concentrated eluent	60 min	0.5 mL/min
3.	Rinse with ultrapure water	15 min	0.5 mL/min
4.	Rinse with eluent	60 min	0.5 mL/min

Metrosep A Supp 4 - 250/2.0		Duration	Flow rate
1.	Rinse with ultrapure water	15 min	0.1 mL/min
2.	Rinse with 10x concentrated eluent	60 min	0.1 mL/min
3.	Rinse with ultrapure water	15 min	0.1 mL/min
4.	Rinse with eluent	60 min	0.1 mL/min

Table 6 Contamination with high-valence hydrophobic ions or organic contamination

Metrosep A Supp 4 - 250/4.0		Duration	Flow rate
1.	Rinse with ultrapure water	15 min	0.5 mL/min
2.	Rinse with 5% acetonitrile	10 min	0.5 mL/min
3.	Rinse with 100% acetonitrile	60 min	0.5 mL/min
4.	Rinse with 50% acetonitrile	10 min	0.5 mL/min
5.	Rinse with ultrapure water	30 min	0.5 mL/min
6.	Rinse with eluent	60 min	0.5 mL/min

Metrosep A Supp 4 - 250/2.0		Duration	Flow rate
1.	Rinse with ultrapure water	15 min	0.1 mL/min
2.	Rinse with 5% acetonitrile	10 min	0.1 mL/min
3.	Rinse with 100% acetonitrile	60 min	0.1 mL/min
4.	Rinse with 50% acetonitrile	10 min	0.1 mL/min
5.	Rinse with ultrapure water	30 min	0.1 mL/min
6.	Rinse with eluent	60 min	0.1 mL/min



6.2 Decreasing resolution / peak shapes

Problem

The resolution of peaks deteriorates or peak shapes are asymmetrical.

Causes and prevention

Causes	Prevention/correction
The separation column has been overloaded	<p>The separation column can be overloaded by factors such as a high salt content in the sample matrix.</p> <ul style="list-style-type: none"> ▪ Dilute the sample. ▪ Inject less sample.
There are dead volumes in the IC system	<ul style="list-style-type: none"> ▪ Check that all of the capillaries have a diameter of ≤ 0.25 mm (6.1831.010). If they do not, replace those capillaries with thinner capillaries. ▪ Check that all of the capillaries have been installed correctly. The step-by-step installation process is shown in the IC Maintenance multimedia guide.

6.3 Unstable retention times

Problem

The retention times are unstable.

Causes and prevention

Causes	Prevention/correction
Carbonate in the eluent	<p>Carbon dioxide from the air affects the carbonate/hydrogen carbonate balance in the eluent. The eluent becomes weaker over time.</p> <ul style="list-style-type: none"> ▪ Always keep the eluent bottle and bottles with eluent concentrates well sealed. ▪ Always use a CO₂ adsorber.
Air bubbles in the eluent	<p>Air bubbles make the eluent flow rate unstable. Backpressure is one indicator of an unstable flow rate. Backpressure should remain stable within ± 0.1 MPa.</p> <ul style="list-style-type: none"> ▪ Deaerate the high-pressure pump. ▪ Use the eluent degasser.

6.4 Unknown peaks

Problem

The chromatogram contains wide, unknown peaks.

Causes and prevention

Causes	Prevention/correction
Analytes eluting late	<p>Some wider, unknown peaks can be the result of sample components eluting late. In these cases, this is the result of the previous injection.</p> <ul style="list-style-type: none"> ▪ Extend the chromatogram duration.

6.5 Increasing backpressure

Problem

The backpressure increases.

Causes and prevention

Causes	Prevention/correction
Particles on the guard column	<ul style="list-style-type: none"> ▪ Replace the guard column.
Particles on the separation column	<p>Rinse the separation column in the direction opposite to the flow direction.</p> <ul style="list-style-type: none"> ▪ Hold the column outlet in a beaker. ▪ Rinse the separation column for approximately 1 h. ▪ Install the separation column back in the flow direction.
Particles in the sample	<ul style="list-style-type: none"> ▪ Sample preparation, e.g. removing particles through Inline Ultrafiltration.

