

Now sold under the
Thermo Scientific brand**Thermo**
SCIENTIFIC

Determination of Transition Metals in Complex Matrices by Chelation Ion Chromatography*

INTRODUCTION

The determination of trace elements in complex matrices remains one of the most challenging areas of analytical chemistry. Complex matrices include seawater, brines, estuarine waters, as well as biological, botanical, and geological materials. In general, these matrices have high levels of alkali and alkaline earth metals with trace levels (less than 1 ppm) of the transition elements. High levels of alkali and alkaline earth metals cause significant interferences and/or sensitivity losses for most analytical techniques used for trace metal determinations. This technical note describes chelation concentration, a selective concentration method, coupled directly to an ion chromatograph for the determination of transition metals in complex matrices. This new method—*Chelation Ion Chromatography*—combines analyte concentration and matrix elimination with analytical separations and selective detection for transition and lanthanide metals. The result is a chromatographic technique that permits trace and ultratrace determinations of metals in a variety of sample matrices, especially those high in alkali and alkaline earth metals.

See Dionex Technical Note 27 for a method describing the determination of lanthanides using chelation IC.

SUMMARY OF THE METHOD

A chelating concentrator column, the MetPac™ CC-1, is used to selectively concentrate polyvalent metal ions from an aqueous sample. Typical sample volumes are 5 to 50 mL. Alkali metals and anions are not retained by the chelating column. Alkaline earth metals are selectively eluted to waste. This form

Introduction	1
Summary of the Method	1
Instrument Requirements	2
Chemicals, Reagents, and Standards	5
Other Supplies	5
Discussion of the Method	5
System Preparation and Setup	7
System Test	9
System Operation	11
Calibration	13
Quantitation/Calibration	13
System Linearity	14
Sample Preparation	14
Sample Analysis	14
Sample Volume	15
Applications of Chelation Ion Chromatography	15
Appendix A: Required Reagents and Standards	17
Appendix B: Preparation of Standards	19
Appendix C: Sample Loop	20

of selective sample pretreatment is called *chelation concentration*. The concentrated transition metals and lanthanides are then eluted to a second concentrator column, the TMC-1. The TMC-1 is then converted to a salt form and switched in line with the analytical column, the IonPac® CS5. The concentrated metals are then separated.

*Chelation Ion Chromatography is patent pending.



Detection is accomplished by visible absorbance after postcolumn derivatization with a metallochromic indicator. The analytical chromatography for transition metals requires about 15 minutes. Detection limits range from 0.1 to 0.5 ng. Detection limits of 0.2 to 1 ng/mL (ppb) can be obtained with a 20-mL sample volume. This method is applicable to a wide variety of sample matrices.

The MetPac CC-1 will concentrate most cationic transition and lanthanide elements. Currently, the analytical chromatography is applicable to iron, copper, nickel, zinc, cobalt, manganese, cadmium, lead, and the lanthanide metals.

INSTRUMENT REQUIREMENTS

This technical note gives a detailed description of the system components, installation, and operation of the chelation ion chromatographic system. Please consult the procedures within this technical note carefully before operating the chelation IC system. It is important to understand each step of the sample pretreatment process to maintain the best performance of the chelation IC system. The two recommended system configurations are given; both configurations include the Advanced Gradient Pump (AGP), a Sample Concentration Module (SCM), a Reagent Delivery Module (RDM), and a Variable Wavelength Detector Module (VDM-2). The AGP performs the steps of chelation concentration and controls the valves. A DQP (sample pump) in the SCM is used for loading the sample onto the MetPac CC-1 chelating column. Another DQP (carrier pump) with a pulse damper is used as the eluent pump. Five 4-way valves are located in the front section of the SCM.

System 1 is configured for manual operation, while system 2 is for automated operation. System 1 requires adjustment of the sample pH to 5.5 prior to sample introduction. However, an acid sample of pH 1-2 can be loaded directly into system 2. The sample introduction mode of the two systems also differs; system 1 uses a DQP pump to deliver the sample directly to the MetPac CC-1 concentrator, and system 2 uses a fixed sample loop.

To improve the detection limits of the chelation IC system, a Membrane Reactor is recommended in place of the mixing tee. The Membrane Reactor lowers detection limits for metals 5-fold compared to reagent addition using the mixing tee. The Membrane Reactor should be used if you are determining transition metals below 0.5 ppb. A knitted or beaded reaction coil should always be used with the Membrane Reactor.

Chelation Ion Chromatograph—System 1

A schematic of system 1 is shown in Figure 1.

Advanced Gradient Pump (AGP, P/N 43116)
Sample Concentration Module (SCM, P/N 42134)
Reagent Delivery Module (RDM, P/N 37030)
Variable Wavelength Detector Module (VDM-2, P/N 39646, internal or remote cell)
Eluent Degas Module (EDM-2, P/N 39550)
Eluent Container Set, Glass (P/N 38752)
IonPac Membrane Reactor (P/N 35354—optional)
Knitted Reaction Coil (P/N 39349) or Beaded Reaction Coil (P/N 36036)
MetPac CC-1 Column (P/N 42156)
TMC-1 Column (P/N 42155)
Ion Pac CG5 (P/N 37029)
IonPac CS5 (P/N 37028)
Backpressure Regulator (P/N 39760)
Data acquisition system or AI-450 Chromatography Workstation with ACI interface

Chelation Ion Chromatography—System 2

A schematic of system 2 is shown in Figure 2.

Advanced Gradient Pump (AGP, P/N 43116)
Sample Concentration Module (SCM, P/N 42134)
Reagent Delivery Module (RDM, P/N 37030)
Variable Wavelength Detector Module (VDM-2, P/N 39646, internal or remote cell)
Air Pressure Regulator (P/N 38207)
Eluent Container Set, Glass (P/N 38752)
Slider double stack, 4-way valve, 2000 psi/13.7 MPa (P/N 35914)
Slider Single Stack, 4-way valve, 2000 psi/13.7 MPa (P/N 38754) or slider double stack, 4-way valve, 2000 psi/ 13.7 MPa (P/N 35914), two (2) required
IonPac Membrane Reactor (P/N 35354 - optional)
Knitted Reaction Coil (P/N 39349) or Beaded Reaction Coil (P/N 36036)
MetPac CC-1 Column (P/N 42156)
TMC-1 Column (P/N 42155)
IonPac CG2 (P/N 35370)
IonPac CG5 (P/N 37029), two (2) required
Data acquisition system or AI-450 Chromatography Workstation with ACI interface

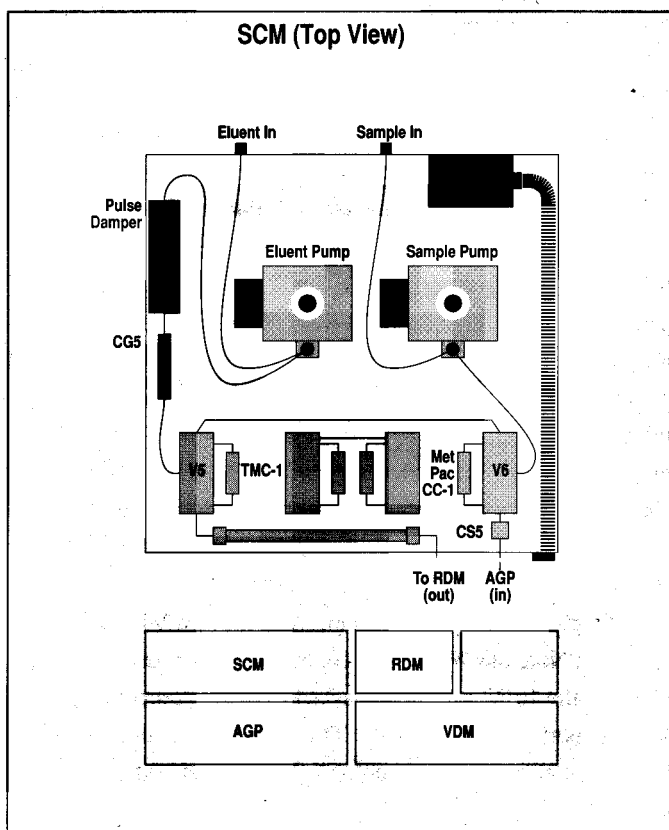

Figure 1 Chelation IC system 1

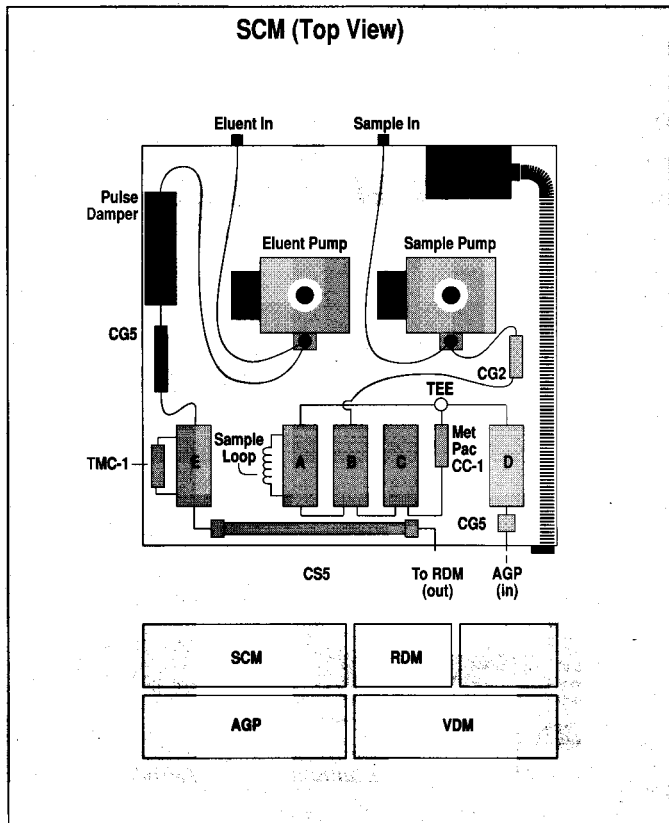

Figure 2 Chelation IC system 2

System Configuration

The two recommended systems contain the Sample Concentration Module (SCM) and the Advanced Gradient Pump (AGP).

Sample Concentration Module (SCM)

The block schematics of the SCMs used for systems 1 and 2 are shown in Figures 1 and 2. The SCM contains two single piston Dionex DQP pumps (maximum pressure 1900 psi/13.1 MPa), inert double stack four-way pneumatically controlled slider valves, and a pulse damper. One DQP is used to pump sample into the system; the other DQP is used to deliver eluent to the IonPac CS5 analytical column. All of these components are housed in the SCM's single enclosure. The SCM rear panel contains bulkhead fittings for connecting waste lines and eluent lines.

Advanced Gradient Pump (AGP)

The AGP is a microprocessor controlled, high performance quaternary gradient IC pump with a metal-free flow path. It permits the time dependent selection of up to four different eluents, flow rate, and the control of two sets of air solenoids for external valve control. Controls 5 and 6 of the AGP (referred to as E5 and E6) are used to control the five SCM valves. The AGP is programmable and can store up to 10 programs. Refer to the *AGP Operator's Manual* for complete information on operation and maintenance.

Using appropriate interface hardware, the AGP can be controlled by a Dionex integrator or the AI-450 Chromatography Workstation. To automate the system for sample concentration of 1 to 3-mL samples, the Dionex Automated Sampler Module (ASM) can also be used and controlled by the integrator or the AI-450.

System 1

Figure 3 shows a pneumatic and hydraulic schematic of the chelation IC system. Configure the instrumentation as shown in Figure 1 and plumb the system as shown in Figure 3.

Connect the four air lines from the rear panel of the SCM. Color match the air lines. Valves 1, 2, and 3 of the SCM are controlled by E5 of the AGP and are connected by the orange (top) and yellow (bottom) air lines. Valve 4 of the SCM is controlled by E6 of the AGP and is connected by the blue (top) and green (bottom) air lines.

System 2

Figure 2 shows a detailed pneumatic and hydraulic schematic of the SCM system 2. The SCM is factory-configured for sample pretreatment use with an external detector (e.g., ICP). For chelation IC applications, configure and plumb the SCM as shown in Figure 4.

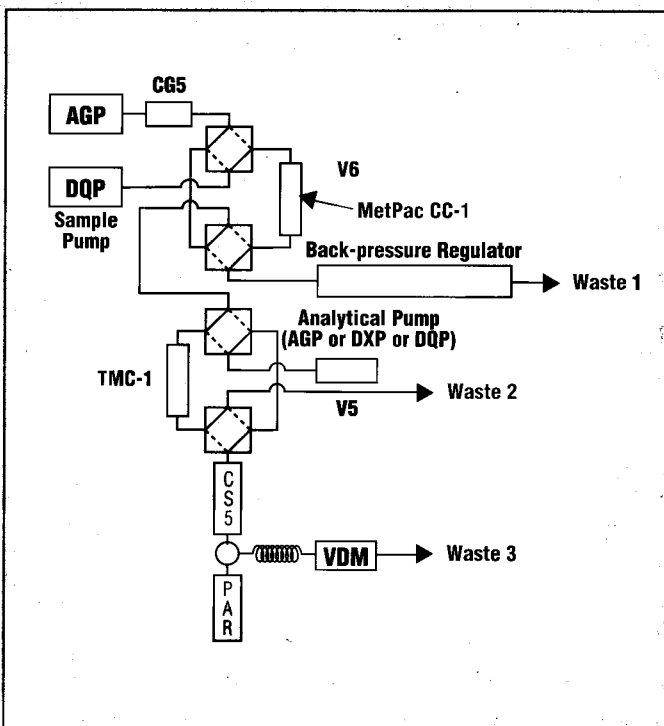

Figure 3 Schematic of Chelation IC System 1

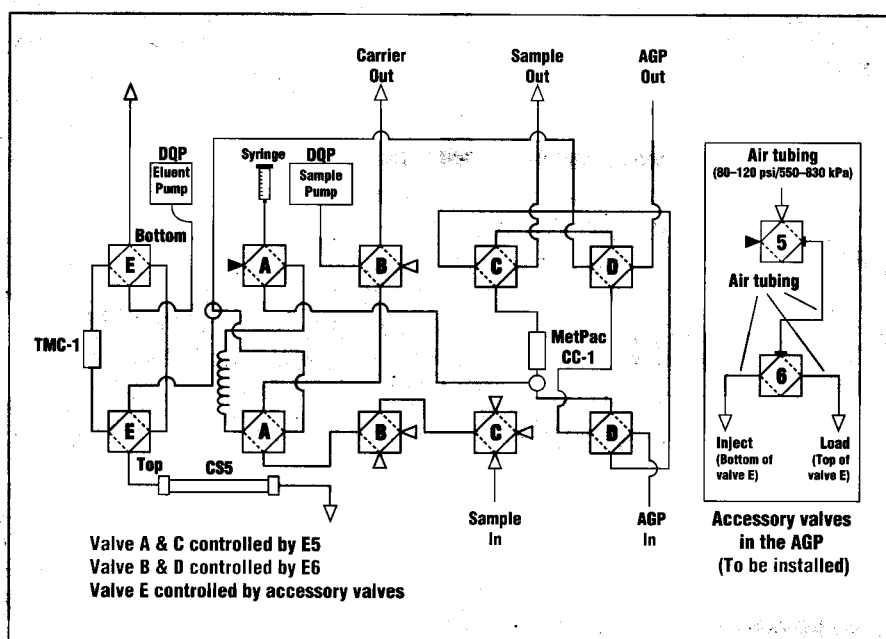

Figure 4 Schematic of Chelation IC System 2

Pneumatic Connections

Disconnect all the air tubings in the SCM and reconnect as indicated in Figure 4. Be sure that valves A and C are controlled by E5 and that valves B and D are controlled by E6. Valve E is controlled by the accessory valves that will be installed inside the AGP. To install the AGP accessory valves in the AGP and the air tubing between the AGP and the SCM, locate the four colored air tubings at the rear panel of the AGP and the SCM. Using four small barbed tees (P/N 30538), connect the air tubing by matching the colors (orange-orange, yellow-yellow, green-green and blue-blue) to the two arms of the barbed tee. Connect 12 in. (30 cm) each of the orange and green air tubing from each tee to the top of the two slider-single-stack four-way valves (P/N 38754). The valve with orange tubing on the top is designated as V1, the other as V2. Repeat this step by connecting the yellow and the blue tubings to the bottom of V1 and V2, respectively. Place V1 and V2 in the AGP. Note that V1 is now controlled by E5, and V2 by E6. Connect the 10/32 x 1/16-in. barbed fittings to port 1 and 2 of V1, and port 1, 2, and 4 of V2. Then, connect about 6 in. (15 cm) of air tubing between port 2 of V1 and port 1 of V2, as shown in Figure 3. V1 and V2 will be used to switch valve E located in the SCM. Plug port 4 of V1 with 1/8-in. fitting.

Next, connect about 24 in. (60 cm) of air tubing (P/N 30091) to the small barbed fitting on the back of the AGP. Insert a barbed tee (P/N 30538) into the end of this tubing. One arm of the tee will go to the nitrogen source (regulator) and the other arm to port 1 of V1. Connect about 36 in. (90 cm) of air tubing between port 4 of V2 and the top of valve E located in the SCM.

Repeat this step with port 2 of V2 and the bottom of valve E.

Next, connect the air tubing from the nitrogen or argon source by using a barbed tee (P/N 30538) and connect the air tubing to the inlet of the eluent bottle regulator (P/N 38201). Using the required lengths of the tubing, connect the tee to the gas source and to the eluent pressure regulator. Using the 1/4-in. x 10/32 brass reducer (P/N 30087) and the 10/32 x 1/16-in. barbed fitting (P/N 30017), connect the air tubing to the gas source regulator.

Next, connect the air tubing to the eluent container caps (P/N 41004) and to the 4-L plastic eluent container cap (P/N 39164). Start by cutting one of the two 1/8-in. Teflon

lines flush with the bottom of the cap. Repeat this for all five eluent container caps. Next, cut the same tubing about 2 in. (5 cm) above the eluent container cap. This line will be used to connect the argon or nitrogen for pressurizing the eluent bottles. Confirm that the eluent bottle caps contain a white TFE O-ring (P/N 41078). Insert a barbed coupler (P/N 42241) into the trimmed Teflon line of cap E1. Insert a barbed tee (P/N 30538) into the trimmed Teflon lines of caps E2, E3, E4, and E5. Connect the eluent caps using the air tubing (P/N 30091 or equivalent). This completes the pneumatic setup.

Hydraulic Connections

Refer to the *AGP* and *SCM Operator Manuals* for complete information on the installation and operation of the respective modules. Begin the hydraulic connections by cutting the four eluent lines from the four eluent container caps to the front panel eluent port of the AGP. Notice that the eluent lines are labeled 1, 2, 3, and 4. Be sure the eluent lines are connected to the appropriate eluent port.

Connect the eluent line from the 4-L plastic eluent container (P/N 39164) to the "sample in" port of the SCM rear panel. This port is connected to the check-valve inlet of the sample pump located on the right side of the SCM. Next, connect the three blue waste lines (P/N 39341) to the ports of the SCM rear panel labeled CARRIER OUT, AGP OUT, and SAMPLE OUT, and place them in a waste container. Also, place another waste line from valve E in the waste container. This completes the hydraulic connections.

Electrical Connections (for System 1 & 2)

Verify that the front PUMP 1 and PUMP 2 power switches of the SCM are off. Using the power cords provided (P/N 96078), connect the AC receptacles on the rear panels of the SCM and AGP to the white outlets of the power strip located on the rear upper section of the system enclosure. Next, connect the AC receptacle of the power strip enclosure to an AC power outlet.

If you wish to control the system via an interface cable to a Dionex integrator, consult your Dionex service representative for further details.

CHEMICALS, REAGENTS, AND STANDARDS

A complete list of reagents and instructions on their preparation can be found in Appendix A. The reagents used for chelation concentration, 2 M ammonium acetate pH 5.5, 2 M nitric acid, and 0.1 M ammonium nitrate pH 3.5 are available from Dionex. In addition, high purity water containing less than 500 parts-per-trillion of common transition elements (iron, zinc, copper, manganese, etc.) is also required.

OTHER SUPPLIES

In addition to the items listed above, you will also need

Electrical power

Compressed nitrogen (80-120 psi/550-830 kPa)

Standard analytical laboratory equipment such as a balance, pH meter, etc.

DISCUSSION OF THE METHOD

The method described in this manual is intended for the determination of transition metals in complex matrices. The term *complex matrix* refers to any matrix containing constituents that commonly interfere with the analytical measurement. The detection limits for analytes may be severely compromised using conventional analytical techniques for complex matrices. For example, large quantities of alkali and alkaline earth metals can interfere with the determination of transition metals by IC or atomic spectroscopy. With chelation IC, it is possible to eliminate or reduce these interferences before the analytical determination, while at the same time concentrating the analytes of interest. By using selective ion exchange materials such as chelating resins, analytes can be concentrated, while common interferences such as the alkali and alkaline earth metals and anions are reduced or eliminated. This form of sample pretreatment is called *chelation concentration*. Unlike conventional ion exchange concentration methods, which are typically not selective for ions of the same valency, chelation concentration is a *selective* concentration method.

Chelation concentration is applicable to samples such as seawater, brines, natural waters, waste waters, acid digested samples, concentrated acids, bases, and biological, botanical, and geological materials. *Chelation concentration is not intended for trace transition metal determination in the presence of large quantities of other transition metals (e.g., plating baths).*

Most samples should be acid digested to ensure that the metals are free in solution and not bound by organic materials such as fulvic and humic acids. Metal ions bound by complexing agents in the sample can interfere with the concentration efficiency and recoveries.

The column used for chelation concentration, the MetPac CC-1, contains a macroporous iminodiacetate chelating resin. The column has a capacity of 0.45 milliequivalent. The relative selectivity of the resin is

Lanthanides > Hg >> Cu >> UO₂ > Ni > Pb > Zn >
Co > Cd > Fe > Mn > Ba > Ca > Sr > Mg >> Na

In general, the higher the cationic charge of the metal ion, the more strongly bound the metal ion is to the resin. Anionic forms of metals, such as Cr (VI) as chromate (CrO_4^{2-}), are not retained. Since the functional group of the resin is a weak acid (COOH) and a weak base (NH), as shown in Figure 5, hydronium ion (H_3O^+) competes strongly with metal ions for the chelating sites. As a result, mineral acids such as hydrochloric or nitric acid at 0.5 to 2.0 M are effective eluents. Below pH 2.5, the MetPac CC-1 column will not concentrate transition metals. In the pH range 5–6, the resin selectivity is optimized for transition and lanthanide metals relative to alkali and alkaline earth metals. By using an ammonium acetate eluent in this pH range, alkaline earth metals can be eluted, while the transition and lanthanide metals remain strongly bound to the resin.

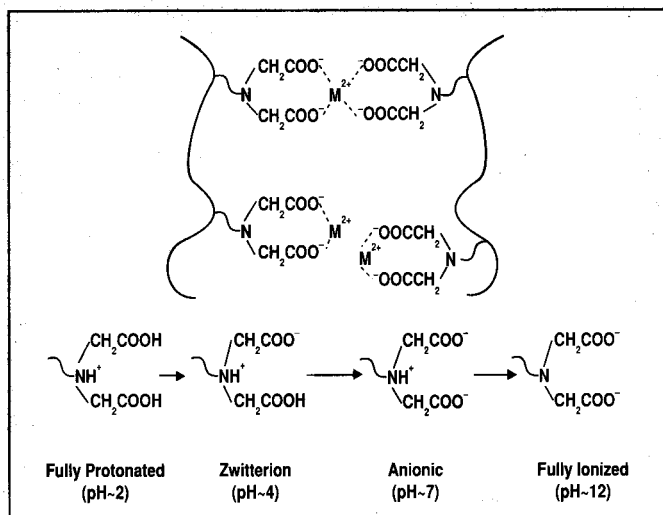

Figure 5 Properties of MetPac CC-1 chelating resin

Chelation concentration consists of four major processes.

1. The buffered (pH 5.5) sample is passed through the chelating concentrator, the MetPac CC-1. Most polyvalent cations are quantitatively concentrated from the sample, while anions and alkali metals pass through the column essentially unretained. Metals that are quantitatively concentrated are listed in Table 1.
2. Weakly bound alkaline earth metal ions such as magnesium and calcium are selectively eluted using a 2 M ammonium acetate eluent (pH 5.5) pumped by the AGP. During this elution process, at least 95% of the magnesium and 90% of the calcium on the column will be eliminated. Some manganese (10 to 15%) will be eluted, but this is not a problem since the percentage of manganese eluted during the ammonium acetate wash is constant.
3. The concentrated transition and lanthanide metals are eluted in a 100 to 200- μL volume using nitric or hydrochloric acid delivered from the AGP.
4. After a final acid rinse (1 to 2 M) to completely remove residual metals, the MetPac CC-1 is converted back to the ammonium form using 2 M ammonium acetate.

While mineral acids efficiently elute the concentrated metal ions from the MetPac CC-1, acids are not compatible with the eluent system of the analytical column (IonPac CS5). A high capacity cation exchange concentrator must be used to retain the metal ions as they are eluted from the MetPac CC-1. The TMC-1 contains a fully sulfonated cation exchange resin with sufficient capacity (0.3 meq) to retain the metal ions under elution conditions from the MetPac CC-1. The TMC-1 interfaces the high capacity chelating column with the low capacity analytical column. Before the TMC-1 can be switched in line

Table 1
Retention Characteristics of the MetPac CC-1 Concentrator

Metal Ion	Quantitative	Metal Ion	Quantitative
Ti (IV)	Yes	Cd (II)	Yes
V (IV, V)	Yes	In (III)	Yes
Cr (III)	No	Y (III)	Yes
Mn (II)	Yes	Lanthanides	Yes
Fe (II, III)	Yes	Hg (II)	Yes
Co (II)	Yes	Pb (II)	Yes
Ni (II)	Yes	Al (III)	Yes
Cu (II)	Yes	Tl (I, III)	No
Zn (II)	Yes	As (III, IV)	No
Ag (I)	Yes	Se (IV, VI)	No

Table 2
Chemistry of Chelation Ion Chromatography

1. Sample pH adjusted to 5.2 to 5.6 and concentrated either on-line or off-line using the MetPac CC-1: Alkali metals and anions unretained, polyvalent metal ions concentrated.
2. Selective elution of alkaline earth metals using ammonium acetate.
3. Concentrated metals eluted to TMC-1 concentrator using nitric acid.
4. TMC-1 converted from hydronium to ammonium form: concentrated metals remain on TMC-1.
5. TMC-1 switched into analytical stream where concentrated metals are eluted to the analytical separator (CS5).

with the analytical stream, it must be converted from the acid (H^+) form to the ammonium (NH_4^+) form. This is accomplished using 0.1 M ammonium nitrate, pH 3.5, which is also pumped from the AGP. Converting the column from the acid form to

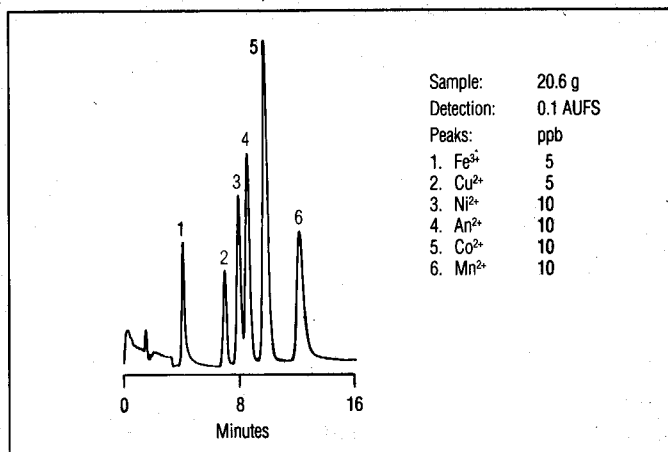

Figure 6 PDCA separation of transition metals using Chelation Ion Chromatography

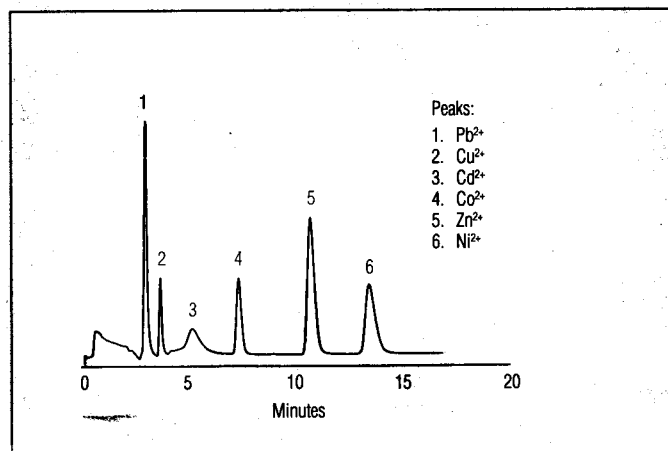

Figure 7 Oxalate separation of transition metals using Chelation Ion Chromatography

the ammonium form prevents a pH disturbance of the weak acid eluents. If the pH of the analytical eluents is disrupted, the analytical chromatography is adversely affected. If only transition metals are to be determined, the TMC-1 is switched in-line with the analytical eluent. The concentrated metals are eluted directly to the Ion Pac CS5 for the analytical separation. Table 2 summarizes the chemistries of chelation IC for transition metals.

The IonPac CS5 separations are based on one of two different eluent systems. The first is a pyridine-2,6-dicarboxylic acid (PDCA) eluent, which is a strong complexing agent that separates the metal ion complexes by anion exchange. PDCA is best suited for iron (II) and (III), copper, nickel, zinc, cobalt, and manganese. As shown in Figure 6, while iron (II) and (III) can be separated on the CS5, the nitric acid used for elution from the MetPac CC-1 causes most of the iron (II) to be oxidized to iron (III). Lead and cadmium elute under these conditions, but are so strongly bound to the PDCA that they are not sensitively detected by the postcolumn reagent.

A second, alternative eluent system uses an oxalic acid-based eluent, which is a moderate strength complexing agent that separates the metals by a mixed mode mechanism. The oxalate eluent separates lead, copper, cobalt, zinc, and nickel. This separation is shown in Figure 7. Cadmium and manganese coelute with this eluent. The isocratic analytical separations of the transition metals requires about 15 minutes.

Separated metals from the analytical column enter a postcolumn reaction system where they are derivatized with 4-(2-pyridylazo)resorcinol and then detected at 520-530 nm using a UV/visible absorbance detector.

It is important to use reagents and water with very low metal contamination (<1 ppb). Any trace metals in the reagents will be concentrated as a blank and subsequently eluted with the sample. The system blank results from contamination in the chelation concentration reagents and the system. Generally, iron and zinc are the most common transition metal contaminants, while a small amount of copper may also be observed. Care must be taken to minimize reagent and sample contamination during preparation and handling. Reagent purity will typically dictate the detection limits. The necessary reagents are described in Appendix A.

If system 1 is used, standards and samples must be buffered before concentration. To ensure complete recoveries for trace metals, the sample should be digested prior to concentration. Also, the solution to be concentrated should have an ammonium acetate concentration of 0.25 M or greater. Buffer the samples and standards to the same ammonium acetate concentration. Ensure that the samples and standards to be concentrated are pH 5.5 by adding 2 M ammonium acetate (pH 5.5).

SYSTEM PREPARATION AND SETUP

System 1

Details for operation of individual system components can be found in the appropriate Operator's Manual.

Refer to Figures 1 and 3 for set-up and plumbing of the chelation IC system. This set-up procedure uses the PDCA transition metal separation.

1. Begin the system setup by making sure there are no metal components in the flow path. This includes tubing end fittings (stainless steel washers, omni-fittings, etc.), columns, and valves that contain stainless steel. Replace all OmniFit grippers with Dionex ThermoFlare™ washers.

Table 3
Chelation Concentration Operating Conditions

Chelation Concentration—Transition Metals

Columns: MetPac CC-1, TMC-1
 Eluents: E1: H₂O
 E2: 2.0 M ammonium acetate, pH 5.4 ± 0.1
 E3: 2.0 M nitric acid
 E4: 0.10 M ammonium nitrate, pH 3.5 ± 0.3

Gradient Program—System 1

t (min)	%E1	%E2	%E3	%E4	V5	V6	Flow (mL/min)
0.0	0	100	0	0	1	0	3.0
0.1	0	100	0	0	1	1	3.0
2.5	0	100	0	0	1	1	3.0
2.6	72	0	28	0	0	1	3.0
5.0	72	0	28	0	0	1	1.0
5.1	0	0	0	100	0	0	3.0
6.6	0	0	0	100	1	0	1.0
6.7	0	0	100	0	1	1	3.0
7.7	0	0	100	0	1	1	3.0
7.8	0	100	0	0	1	1	3.0
9.3	0	100	0	0	1	1	3.0
9.4	100	0	0	0	1	1	0.0

Gradient Program—System 2

t (min)	%E1	%E2	%E3	%E4	V5	V6	Flow (mL/min)
0.0	0	100	0	0	1	0	3.0
2.0	0	100	0	0	0	1	2.0
5.0	0	100	0	0	1	0	3.0
7.0	0	100	0	0	1	0	1.2
7.1	50	0	50	0	1	1	1.2
12.0	50	0	50	0	1	1	1.2
12.1	0	0	0	100	1	1	2.0
13.0	0	0	0	100	0	0	3.0
15.0	0	0	0	100	0	0	3.0
15.1*	0	0	100	0	1	0	4.0
16.0	0	0	100	0	1	0	4.0
17.0	0	0	100	0	1	0	4.0
18.0	0	100	0	0	1	0	0.0

*begin sample analysis

Analytical Chromatography—Transition Metals

Column: IonPac CS5
 Eluent: As shown in Figure 6: 0.0060 M pyridine-2,6-dicarboxylic acid, 0.090 M acetic acid, 0.040 M sodium hydroxide
 Or, as shown in Figure 7: 0.050 M oxalic acid, 0.095 M lithium hydroxide
 Eluent Flow Rate: 1.0 mL/min

Postcolumn Derivatization

Reagent: 4 × 10⁻⁴ M 4-(2-pyridylazo) resorcinol
 1.0 M 2-dimethylamino ethanol
 0.50 M ammonium hydroxide
 0.30 M sodium bicarbonate
 Reagent Addition: Membrane reactor or mixing tee
 Reagent Flow Rate: 0.5 mL/min
 Reactor: Packed or knitted reaction coil

Detection

Detector: Visible absorbance, VDM or UDM
 Wavelength: 520 or 530 nm
 Time Constant: 1 s

- Before connecting the glass eluent bottles to the EDM, remove the endline filters. Since it is not necessary to purge the eluents, shorten the gas lines on the eluent caps so that they are not submerged into the eluents. To do so, remove the gas line, flare the end of the 1/8-in. line with the standard flaring tool, and reinstall the fitting into the eluent bottle cap. Repeat this procedure for all six eluent lines of the EDM. Each eluent bottle cap should contain a white TFE O-ring (P/N 41078), not a black rubber O-ring. Replace black O-rings with TFE O-rings as needed.
- Remove the GM-2 mixers of the AGP. One of the mixers is located between the valve manifold and the priming block of the AGP. Connect the two lines using a union (P/N 39056). Do not install a mixer on the high pressure side of the AGP (i.e., between the AGP and valve 6).
- Prepare 1 L of 0.2 M oxalic acid by dissolving 25.2 g of reagent grade oxalic acid dihydrate in 1 L of deionized water. This eluent will be used to clean the AGP eluent flow path.
- Connect the 0.2 M oxalic acid to E1 of the AGP. Pump the oxalic acid through the AGP and to waste at 2.0 mL/min for 10 min. Repeat this procedure for ports 2, 3, and 4. This helps remove any trace metals from the AGP flow path.
- Pump the 0.2 M oxalic acid through the DQP sample pump and to waste for 15 min at 2 to 3 mL/min. Finally, pump deionized water through the sample pump to remove the oxalic acid.
- Clean four 1-L glass eluent bottles by filling them with 0.2 M oxalic acid. Allow the acid to remain in the eluent bottles for at least 4 hours. Prepare eluents as described in Appendix A. Connect the eluent bottles to the EDM and connect to the AGP. Be sure that the eluents are plumbed to the proper ports of the AGP. Pump each eluent for 5 min at 3.0 mL/min directly to waste.
- Prepare the PAR reagent as directed in Appendix A. Place the PAR reagent in the RDM reagent reservoir and close the reservoir. Turn the RDM reagent 1 switch on and immediately adjust the regulator to 60 psi (410 kPa). Turn the RDM reagent 1 switch OFF. Be sure that PDCA is being pumped through the columns when the RDM is switched on. Failure to do so may result in PAR backing up through the IonPac CS5 column.

9. Enter the gradient program in Table 3 for chelation concentration system 1. This program can be entered from the front panel of the AGP, or if the AI-450 is being used, the program can be entered from the Method Editor.

System 2

1. Confirm that the SCM is configured as given in Figure 2. Be sure that an IonPac CG2 (P/N 35370) column is installed between the AGP and valve D of the SCM. Also, confirm that a CG2 column is present between the sample pump and valve B. Install a MetPac CC-1, TMC-1, and IonPac CG5 and CS5 columns as indicated in Figure 2.
 2. Remove the GM-2 mixer from the low pressure side of the AGP. Connect the two lines using a coupler (P/N 39056). Do not install a mixer on the high pressure side of the AGP.
 3. Prepare 1 L of 0.2 M oxalic acid by dissolving 25.2 g of reagent grade oxalic acid dihydrate in 1 L of the deionized water. This eluent will be used to clean the eluent flow path.
 4. Connect the 0.2 M oxalic acid to E1 of the AGP. Pump the oxalic acid through the AGP and to waste at 2.0 mL/min for 10 min. Repeat this procedure for port 2, 3, and 4. This helps to remove any trace metals from the pump flow path.
 5. Place the sample inlet tube into the 0.2 M oxalic acid solution. Fill each of the four 1-L eluent bottles and the 4-L plastic eluent bottle with 500 mL of 0.2 M oxalic acid. Enter the following program for system preparation. This program is entered from the front panel of the AGP. Refer to the *AGP Operator's Manual* for details on programming the AGP.
- | Time | E1 | E2 | E3 | E4 | V5 | V6 | Flow |
|------|-----|-----|-----|-----|----|----|------|
| 0.0 | 100 | - | - | - | 1 | 0 | 2.0 |
| 5.0 | - | 100 | - | - | 1 | 1 | 2.0 |
| 10.0 | - | - | 100 | - | 0 | 1 | 2.0 |
| 15.0 | - | - | - | 100 | 0 | 0 | 2.0 |
| 20.0 | 100 | - | - | - | 0 | 0 | 0.0 |
6. Replace the 0.2 M oxalic acid in the 4-L plastic bottle with deionized water. Be sure that the cap has an O-ring for proper sealing.
 7. Clean five 1-L glass eluent bottles by filling them with 0.2 M oxalic acid. Allow the acid to remain in the eluent bottle for at least 4 hours. Prepare eluents as described in Appendix A. Use caution in preparing and transferring these re-

agents to minimize contamination. Be sure that the eluents are plumbed to the proper ports. E5 is connected to the CARRIER IN port of the SCM rear panel. (E1: 2.0 M ammonium acetate, E2: 2.0 M nitric acid, E3: water, E4: 0.1 M ammonium nitrate, E5: PDCA or oxalic acid eluent). Adjust the eluent bottle regulator to 4–6 psi (20–41 kPa) and check for gas leaks.

8. Prime the AGP with each eluent.
9. Prepare PAR reagent as directed in Appendix A. Place PAR reagent into the RDM reagent reservoir and close the reservoir. Turn the RDM reagent 1 switch on and immediately adjust the regulator to 60 psi (410 kPa). Turn the RDM reagent 1 switch off. Be sure that PDCA is being pumped through the columns when the RDM is switched on. Failure to do so may cause the PAR reagent to back up through the IonPac CS5 column.
10. Enter the gradient program for chelation concentration. This program can be entered from the front panel of the pump, or if using the AI-450, the program can be entered from the Method Editor.

SYSTEM TEST

System 1

The purpose of this system test is to ensure that all chromatographic and chemical components of the system are operating properly. Refer to Figure 3 for the schematic of system 1.

1. The system test will begin with a test of the hydraulic system. If the system fails the hydraulics test at any point, determine the source of the plumbing error. Begin by programming the AGP as follows:

Eluent 1: 100%
 Flow: 2.0 mL/min
 Valve 5: on (1)
 Valve 6: off (0)

Turn on the AGP. Eluent should begin to flow through valve 6 bypass and through valve 5 to waste line W2. The pressure readout of the AGP should not exceed 50 psi (340 kPa). Next, turn valve 6 on (1). Eluent 1 should begin to flow through MetPac CC-1. The pressure display of the AGP should increase. Disconnect one of the fittings connecting the MetPac CC-1 to valve 6 and confirm that eluent is flowing through the column. Reconnect the fitting when flow has been confirmed. Eluent should be flowing through line W2 to waste.

2. Turn valve 5 off (0). This should now place the TMC-1 in line with the AGP eluent flow. The AGP pressure display should increase. Disconnect one of the fittings connecting the TMC-1 to valve 5 and check for flow through the column. Reconnect the fitting and check for leaks. Turn the AGP off.
3. Using deionized water, prime the DQP sample pump. Set the flow rate to 3 mL/min. Turn valve 6 off (0) and turn on the sample pump. Deionized water should flow through the MetPac CC-1 and to waste line W1. No liquid should be exiting W2.
4. Disconnect the postcolumn system from the analytical column. Set the eluent pump (DQP or AGP) flow rate to 1.0 mL/min. Turn on the eluent pump and set valve 5 to the on (1) position. The deionized water should be flowing through the TMC-1 and to the IonPac CS5 column. Check to see that there is flow from the IonPac CS5.
5. Reconnect the postcolumn system to the IonPac CS5 column. Set the eluent pump flow rate to 1.0 mL/min and turn on the pump. Immediately, turn on the RDM reagent 1 valve to pressurize the postcolumn reagent reservoir and start reagent flow. After 1 min, check to see that the effluent from waste line W3 is yellow. This indicates that PAR is flowing. Measure the flow rate from the waste line. The flow rate should be 1.4–1.6 mL/min. Adjust the RDM regulator to achieve the recommended flow rate. If reagent is not flowing from the detector waste line, begin working backwards from the waste line to determine the source of blockage or high pressure. **Always check to see that reagent is flowing from the detector waste line when starting the system.** This completes the system test.

System 2

The purpose of this system test is to ensure that all chromatographic and chemical components of the system are operating properly. Refer to Figure 4 for a schematic of system 2. Be sure to check all fittings for leaks during the system test.

1. Enter the following gradient program for chelation concentration from the front panel of the AGP. Refer to the *AGP Operator's Manual* for details on programming the AGP. Check the program carefully for accuracy by listing the program.

Eluent 1:	100%
Flow:	2.0 mL/min
Valve 5:	on (1)
Valve 6:	off (0)

The system test will begin with a test of the hydraulic system. If the system fails the hydraulic test at any point, determine the source of the plumbing error. Begin by using the program as given above. With the AGP in the stop-hold position, press RESET. This will set the program to time 0.0.

2. Press START on the AGP. Eluent (E1) should begin to flow to the valve D and out to the AGP OUT at the SCM rear panel. Check AGP OUT to confirm that the eluent is flowing to the SCM.
3. Next, prime the carrier pump by loosening the tubing fitting screwed into the outlet check valve. Since the eluent reservoir is pressurized (5 psi/35 kPa), the eluent (PDCA or oxalic acid) should begin to flow out of the check valve. As the eluent begins to flow, turn on the carrier pump by pressing the PUMP 1 POWER switch on the SCM front panel. After about 5 seconds, replace the outlet check valve tubing fitting. It is generally only necessary to finger-tighten these fittings. If the fitting should leak, tighten it another 1/8 of a turn using a 5/16-in. open-end wrench.
4. Set the stroke dial of the carrier pump to about 5.00 (refer to the *SCM Operator's Manual* for details on adjusting the flow rate). Disconnect the tubing between the pulse damper and the IonPac CG5 column, and confirm that the eluent is flowing out of the pulse damper. After about 90 seconds, connect the IonPac CG5 column to the pulse damper and confirm that the eluent is flowing through IonPac CG5, TMC-1, and IonPac CS5 columns. Prime each connection if necessary.
5. Calibrate the carrier pump flow rate by mass or volume to 1.0 mL/min. Be sure that the eluent reservoir is pressurized to 5 psi (35 kPa). Turn off the carrier pump (PUMP 1).
6. Repeat step 3 on the sample pump. Press the PUMP 2 POWER switch on the SCM front panel. Check to confirm that the deionized water is flowing out of the CARRIER OUT tubing at the SCM rear panel. Calibrate the sample pump flow rate by mass or volume to 2.0 mL/min. Turn off the sample pump (PUMP 2).
7. Place the sample inlet tube in a container of deionized water and draw the deionized water through the sample loop using a syringe. Confirm that the solution is flowing through the sample loop.

- List the gradient program to the next sequence (2.0 min) and press run and hold. This will forward the program to 2.0 min. Check to see that the eluent is flowing out of the SAMPLE OUT tubing at the SCM rear panel. Stop the pump and confirm that the eluent flow stops. Turn on the sample pump (PUMP 2). Check to confirm that the deionized water is flowing out of the same port at the SCM rear panel. Start the AGP, wait 30 seconds and measure the flow rate. The combined flow rate from the sample pump and the AGP must be 4 mL/min. Adjust the sample pump flow rate as needed. Turn off the sample pump (PUMP 2) and the AGP.

In the event that the carrier pump or sample pump loses prime, prime the pump by loosening the tubing fitting on the outlet check valve. If no liquid is in the check valve, use a squirt bottle to squirt some deionized water into the check valve. This will aid in priming the pump. Replace the check valve fitting. This completes the hydraulic test.

- Reset the AGP to time 0.0 min. Start the carrier pump (PUMP 1). This should now place the TMC-1 column in-line with the carrier pump eluent flow. Disconnect the TMC-1 column and confirm that eluent is flowing through the column by turning off the carrier pump (PUMP 1).
 - Forward the gradient program to 8.1 min and start the pump (PUMP 2). This should now place the TMC-1 column in-line. Confirm that the eluent is flowing through the column. Reconnect the TMC-1 column and check for leaks. Turn off the AGP (PUMP 2).
 - Reset the gradient program. Connect the postcolumn system to the IonPac CS5 column. Start the carrier pump (PUMP 1). Immediately turn on the RDM reagent 1 valve to pressurize the postcolumn reagent reservoir and start the reagent flow. After 1 min, check to see that the PAR postcolumn reagent is flowing to the VDM-2. Measure the flow rate from the waste line. The flow rate should be 1.4 to 1.6 mL/min. Adjust the RDM regulator to achieve the recommended flow rate. This completes the system test.
- Check that the system is configured as shown in Figure 3. Confirm that the system has a 80-120 psi (550–830 kPa) inert gas supply.
 - Turn on the absorbance detector. If a variable wavelength detector is being used, set the wavelength to 530 nm. If a filter-based detector is being used, ensure that the filter is 520 or 530 nm. Turn on the visible lamp and set the sensitivity to 0.2 AUFS. Be sure that the detector output is connected to an integrator or data system (AI-450).
 - Enter the program listed in Table 1 in Program 1 of the AGP used for chelation concentration. This is the complete program for chelation concentration. **Check each step of the program carefully.**
 - Turn on the analytical pump (1.0 mL/min) and the RDM. Check to see that PAR reagent is flowing from line W3. If an AGP is being used, check to see that the pressure read-out of the pump does not exceed 900 psi (6.2 MPa). Check slider valve V5 for leaks.
 - Turn on the integrator or monitor and begin to monitor the baseline. At 0.2 AUFS, an essentially noise-free and drift-free baseline should be observed. If the AGP is not at the beginning of the program, reset the program. The AGP should be in the stop-hold position.
 - Once a stable baseline has been obtained, run a complete manual system test. Prepare a Level 2 standard as described in Appendix A. Prime the sample pump with the standard, and concentrate 10-20 mL of sample at a flow rate not exceeding 3.0 mL/min. Collect the sample effluent from line W1 and determine the volume or mass of the sample. Be sure to turn off the sample pump.
 - Next, start the AGP and press RUN to begin program 1. Immediately start the data system. The concentrated sample will be injected into the analytical stream at 6.6 min. Using the PDCA eluent, the first analyte from the CS5, iron(III), should elute between 9 and 11 min. For the chromatogram shown in Figure 6, the data reduction system was initiated at 6.6 min. The last analyte, manganese(II), should elute between 19 and 22 min. If the peaks are much larger than those shown in Figure 6, trace metals from the reagents and system have been eluted with the standard. The blank will decrease with subsequent runs and is not a cause for concern.

SYSTEM OPERATION

System 1

A step-by-step operating procedure for manual operation of the system (system 1) is described below. Table 3 lists the operating parameters for the determination of transition metals.

8. Reset the AGP and data collection device. Start the AGP, press RUN, and start collecting the data. This time the chromatogram will represent the system blank. Repeat this procedure at least three times or until the blank is reproducible and equivalent in magnitude to the chromatogram given in Figure 8. After 10 consecutive blank runs, if the blank is not reproducible or is still elevated, proceed to the next step.

9. Take about 100 mL of deionized water and add 15 mL of 2 M ammonium acetate. Concentrate about 50 mL of the water and analyze. If the resulting chromatograms show significantly higher concentrations of metals (greater than 15% of the blank), the deionized water has unacceptable concentrations of trace metals. The purity of the water must be improved before continuing.

10. At this point, the system is ready for calibration and sample analysis. Refer to the Calibration and Quantification/Calibration procedures later in this technical note.

System 2

This section describes the sequencing and operation of the system components. This system configuration has been designed for use in the fully automated mode, except for the sample introduction step. If the required sample volume is not more than 3 mL, the Dionex ASM autosampler can be used. Samples greater than 5 mL must be introduced using a syringe or a peristaltic pump.

1. Confirm that the system is configured as shown in Figures 2 and 4. Check to see that the system has a 80–120 psi (550–830 kPa) inert gas supply.
2. Turn the absorbance detector on. If a variable wavelength detector is being used, set the wavelength to 530 nm. If a filter-based detector is being used, check that the filter is for either 520 or 530 nm. Turn on the visible lamp and set the sensitivity to 0.2 AUFS. Be sure that the detector output is connected to a data collection system (integrator or ACI/AI450).
3. Enter the program listed in Table 1. Check the program carefully by listing each step of the program.
4. Reset the gradient program at time 0.0 min. Turn on the carrier pump (Pump 1, 1.0 mL/min) and the RDM. Confirm that the PAR reagent is flowing through the detector.

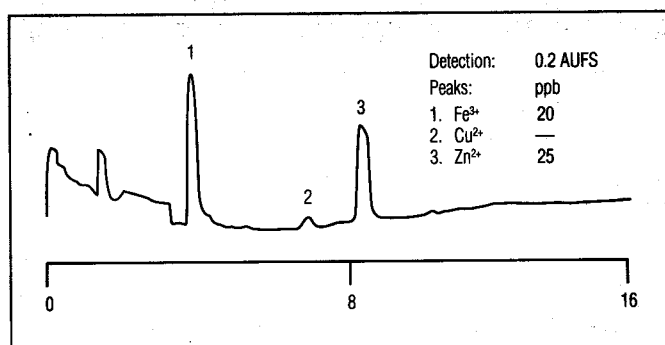

Figure 8 Typical blank obtained using Chelation Ion Chromatography

5. Turn on the integrator or monitor and begin to monitor the baseline. At 0.2 AUFS, an essentially noise-free and drift-free baseline should be observed.
6. Step 1: Once the baseline is stable, press RUN. Confirm that valve 5 is on and valve 6 is off. The sample or the standard can be loaded via autosampler. If the autosampler is not used, load the sample using a syringe to draw the sample through the sample inlet. The sample pH should be 1–2. While the sample is introduced, the AGP is pumping 2.0 M ammonium acetate to regenerate/equilibrate the MetPac CC-1 column. Note that the next step—flushing the sample loop to the MetPac CC-1 and on-line buffering—occurs at 2.0 min. If the sample introduction takes more than 2.0 min, adjust the gradient program accordingly.
7. Step 2: Valve 5 is OFF and valve 6 is ON. The sample pump is pumping deionized water through the sample loop that was previously loaded with sample. The sample stream is now mixing with the 2.0 M ammonium acetate and the buffered sample passes through the MetPac CC-1 column.
8. Step 3: Valve 5 is ON and valve 6 is ON. Valve E now is switched to the load position, where the TMC-1 column is placed in-line with the AGP. Now, the pump is pumping 1.0 M nitric acid to the MetPac CC-1 column. The concentrated metal ions are eluted from the column, and the 1.0 M acid stream is diluted on-line to approximately 0.37 M with deionized water from the sample pump and passes through the TMC-1 column. This step maximizes the removal of concentrated metal ions from the MetPac CC-1 and places them on the TMC-1 column in a tight band.

9. Step 4: Valve 5 is OFF and valve 6 is OFF. 0.1 M ammonium nitrate is pumped to the TMC-1. This step is required to convert the TMC-1 from acid form to ammonium form.
10. Step 5: Valve 5 is ON and valve 6 is OFF. Valve E is now switched to the inject position, where the TMC-1 column is placed in-line with the IonPac CS5 column. The AGP is pumping 2.0 M nitric acid to the MetPac CC-1 for 2 min (3.0 mL/min) and followed by 2.0 M ammonium acetate for 2.0 min (3.0 mL/min) before the end of the chelation concentration process.

You can start chelation concentration at this time for the next sample. Remember that the analysis of the previous sample must be completed before proceeding to step 3 where the TMC-1 column is switched in-line with the MetPac CC-1. The analysis time for transition metals is normally within 15 min. The gradient program may be adjusted so that step 3 can proceed at 15.0 min.

11. Reset the AGP and data collection device. Start the overall cycle without injecting the sample. This run will represent the system blank. Repeat this cycle at least three times or until the blank is reproducible.
12. At this point, the system is ready for calibration and sample analysis. Refer to the appropriate section of this manual for details on calibration and quantification.

CALIBRATION

External calibration is recommended for this method and can be performed using either single level or multilevel calibration. Single level calibration generally yields good precision if the analyte concentration is within a factor of 5 to 10 of the standard concentration. For a greater working (concentration) range, a multilevel calibration is recommended.

Measurement of the standard and sample peak areas or heights and the subsequent calculation of the sample concentration is performed by either AI-450 or the integrator. Refer to the appropriate operator's manual for details of the calibration and quantification procedures.

Single Level Calibration

Single level calibration is performed by determining peak area(s) or height(s) for a standard containing a known concentration of the analyte(s) of interest. Then, the sample is run and the analyte(s) concentration is determined from the ratio of the sample peak area(s) to the standard peak area(s). Single level calibration is simple and rapid and is generally most useful for providing a relatively accurate estimation of analyte concentration. As long as the mass of sample analyte(s) is approximately equal (within a factor of three to five) to the mass of standard analyte, single level calibration will result in acceptable quantification.

Multilevel Calibration

Multilevel calibration is performed by determining peak height(s) or area(s) of standards at several concentrations. A calibration curve is established by plotting peak area or height for each analyte on the Y axis and the analyte concentrations on the X axis. A curve is fit mathematically to the points to establish a calibration curve for each analyte. The sample analyte concentration is determined by finding the point on the calibration curve that corresponds to the measured peak area or height. Multilevel calibration should be performed with two to four standards per decade of concentration. Multilevel calibrations generally give more precise quantification as well as increasing the working concentration range for quantification.

QUANTIFICATION/CALIBRATION

In the concentration mode, the quantity (mass or volume) of standards and samples concentrated must be determined with good precision. This can be accomplished by measuring time to determine volume (flow rate x time), direct volume, or mass. Measuring direct volume or mass is more precise and is recommended. A mass measurement can be readily obtained by taring a beaker on a top loading balance, collecting the sample as it passes through the concentrator (MetPac CC-1), and then weighing the beaker.

When samples are analyzed by concentration techniques, calibration is performed using the external standard method. In external calibration, a plot is made for peak area or height (Y axis) versus the mass of analytes (X axis) concentrated for a standard (single level) or a series of standards (multilevel). A best-fit curve is drawn through the points. Quantification of unknowns is accomplished by finding the point on the curve (analyte mass) that corresponds to the measured peak area. Analyte concentration is then calculated by dividing analyte mass by the volume concentrated.

For the standards, the mass of analyte is calculated from the following equation:

$$M_x = Q_s / C_x$$

where M_x is the mass of the analyte x , Q_s is the quantity (mass or volume) of the standard (or sample) concentrated, and C_x is the concentration of analyte x .

For the samples, the concentration of analyte(s) is calculated from M_x/Q_s , where M_x is obtained from the calibration plot. Refer to the *AI-450 Operator's Manual* for details on integration and calibration. Refer to Appendix B for the recommended concentrations of standards.

SYSTEM LINEARITY

The linear range of this method is approximately 0.2 to 150 ng, depending on the metal ion. The linear range is expressed in mass because we are concentrating and can readily vary the volume of standard or sample loaded. Above 150 ng of analyte, column overload occurs, distorting peak symmetry, which affects resolution and quantification. For most analytes, concentration levels of 0.2 ng approach the detection limit and thus diminish the ability to accurately measure the signal.

SAMPLE PREPARATION

It is beyond the scope of this text to describe in detail the techniques of ultratrace analysis in terms of sample collection, storage, and handling. Several points will be discussed, however, that apply to sample preparation before analyzing samples by the method described in this technical note.

Samples should be collected in *clean* polyethylene containers. In order to stabilize the sample for storage, the sample should be acidified to a pH 1.5 to 2.0. Be sure to use ultrapure nitric acid to adjust the pH.

To ensure complete recovery of metals using chelation concentration, metal ions should not be bound by any strong complexing agents or be present as hydroxy complexes. Acid digestion is a general technique used to destroy complexing agents or to minimize their complexation ability. If the samples being analyzed contain solid material and/or large amounts of organic materials (e.g., humic acids), the samples should be digested prior to analysis. In general, if you have used digestion for sample pretreatment prior to metal analysis, those same digestion procedures can be used in this method.

If system 2 is used, the sample pH must be adjusted to pH 1–2 with ultrapure ammonium hydroxide.

If system 1 is used, the sample pH must be adjusted to 5.3 to 5.6 using ultrapure 2–6 M ammonium acetate (pH 5.5). For optimum concentration, the final ammonium acetate concentration in the sample should be 0.25–1.0 M. Since the addition of any reagent to the sample adds trace metals, use the minimum amount of ammonium acetate needed for sample pH adjustment. Use care in transferring the ammonium acetate to the sample to avoid contaminating the sample with metals. Do not use plastic pipet tips because they are contaminated with zinc. Use a glass pipet for small volumes and graduated cylinders for larger volumes. Alternatively, add the ammonium acetate by mass directly from the polyethylene container. For approximately 100 mL of sample at pH 2, add 15.45 g (15.0 mL) of the 2 M ammonium acetate. If the sample has been digested and the final acid concentration is 0.5 M, a 100-mL digested sample will require about 52 g (50 mL) of the 2 M ammonium acetate. If the levels of metals in the digested sample are above 100 ppb, the sample can be diluted and the corresponding amount of ammonium acetate added to adjust the pH. Be sure to prepare and analyze a blank. The blank contains everything (nitric acid, ammonium acetate) except for sample.

If the sample contains percent levels of aluminum, iron, or silica, adding buffer solution will destabilize the solution and result in the formation of a precipitate or gel. The precipitate or gel is a hydroxide and/or oxide of the aluminum and iron resulting from hydrolysis of the aluminum and iron, which occurs at the higher pH. Since the hydrolysis reactions are quite slow (minutes) at pH 5.5, it is possible to add the buffer solution and immediately begin chelation concentration before precipitation begins. **Never attempt to concentrate a sample containing solids or suspended (colloidal) materials.**

SAMPLE ANALYSIS

System 1

Before concentration, all standards and samples must be buffered to pH 5.2–5.6. This is done most readily by adding an aliquot of the 2 M ammonium acetate, pH 5.5, to the standard or sample just before concentration. The ammonium acetate concentration in the sample of standard should be at least 0.25 M.

Begin sample analysis after the instrument has been calibrated. Sample loading should be done with the AGP reset ($t = 0$) and in the hold position. A quality control standard should be run at least every 10 samples.

Be sure to turn the sample pump on for at least 1 minute before loading the sample on the MetPac CC-1. With valve 6 in the off (1) position, which occurs at the end of the chelation con-

centration program, sample can be pumped to waste. This minimizes sample carry-over from the pump and sample line.

In a seawater matrix, the MetPac CC-1 column can concentrate up to 300 mL before breakthrough of the trace metals occurs. In a brine matrix, which contains low levels of calcium and magnesium (less than 500 ppm), larger sample volumes can be concentrated (up to 1 L). Brine matrices containing 20% sodium chloride have been analyzed with quantitative recovery of the transition and lanthanide metals.

For concentrated acids and bases, it is best to dilute to 3 M or less and buffer. Large sample volumes (1 L) can be concentrated as long as the pH is about 5.5.

System 2

All standards and samples to be introduced in this system must not contain greater than 3% acid. If the acid content exceeds 3%, the samples or standards must be neutralized with ultrapure ammonium hydroxide. The recommended adjusted sample pH is between 1–2.

Begin sample analysis after the instrument has been calibrated. Unlike the system 1 method of operation, in which the sample introduction step is independent of the AGP sequence, the overall process (i.e., sample loading, on-line buffering, etc.) performed by system 2 is executed by the gradient program. The sample can be introduced into the system directly after the pump is in RUN mode. A quality control standard should be run at least every 10 samples.

SAMPLE VOLUME

The volume of sample to be concentrated will depend on several factors. First, to obtain good precision and to work significantly above the noise level, a minimum of 25 ng of each analyte should be loaded on the MetPac CC-1 column. Second, the mass of sample should fall within the range of the calibration standards. Finally, the mass of sample (and standard) analytes concentrated should be at least three times greater than the blank. This last point is important for iron and zinc, since these two elements exhibit the greatest contamination level. If the levels of metals in the sample are below 10 ppb, at least 10 mL of sample should be concentrated. If the approximate concentrations of metals in the samples are not known, start by concentrating between 10 and 20 mL. After determining the approximate concentrations, the appropriate volume to concentrate can be determined.

Unlike the system 1 method of operation, system 2 uses a sample loop to introduce a constant amount of sample into the

system. The SCM comes factory-equipped with two sample loops—1.0 mL and 5.0 mL. The selection of the sample loop size depends on the concentration of analytes of interest. Because the sample loading step is automated by the program, consult Appendix C for more details about sample loop preparation and appropriate programs.

APPLICATIONS OF CHELATION ION CHROMATOGRAPHY

Seawater

In open ocean seawater, the concentrations of transition metals range from 0.01 to 1 ppb. In bay waters, the levels of transition elements can range from 10 ppb to sub-ppb levels. The concentrations of sodium, potassium, magnesium, and calcium in seawater and bay waters are typically 10, 0.5, 1.5, and 0.5 g/L, respectively. Figure 9 shows the determination of transition metals in bay water obtained at Monterey, California. The sample was prepared by adding 10 mL of 2 M ammonium acetate, pH 5.5, to 90 mL of the bay water. Up to 300 mL of seawater can be concentrated on the MetPac CC-1 without significant loss of the transition metals or lanthanides.

The precision of chelation IC at the low-ppb level in seawater is given in Table 4. Iron typically shows the highest relative standard deviation because of its higher blank and because iron is very strongly bound to the resin.

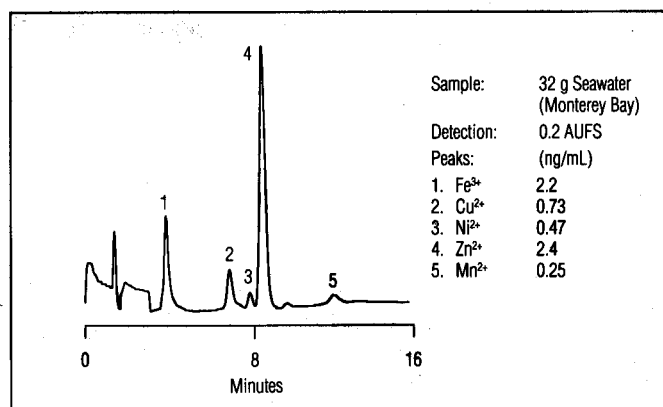

Figure 9 Determination of transition metals in seawater using chelation IC

Table 4 %RSDs for Transition Metals using Chelation Concentration

Sample	Peak Area					
	Fe ³⁺	Cu ²⁺	Ni ²⁺	Zn ²⁺	Co ²⁺	Mn ²⁺
Standard ¹	6.5	3.1	2.4	2.3	0.66	4.3
Seawater ²	13.2	6.9	7.8	7.9	—	6.3

¹ 20 g of 5-ppb Fe³⁺, 5-ppb Cu²⁺, 10-ppb Ni²⁺, 10-ppb Zn²⁺, 10-ppb Co²⁺, 10-ppb Mn²⁺ (n = 11).

² 40 g of Monterey Bay seawater.

Sodium Hydroxide

Transition metals have been determined in concentrated (50%) sodium hydroxide using chelation IC. The sample was diluted 1:10 in deionized water, and then acidified with nitric acid (0.2 mL concentrated nitric per mL of diluted sodium hydroxide). The acidified solution was then diluted 1:1 in 2 M ammonium acetate, pH 5.5. The results are shown in Figure 10.

Magnesium Chloride

Since chelation concentration effectively reduces magnesium while concentrating transition metals, the determination of trace metals in reagent grade magnesium chloride is a straightforward application of chelation IC. In this experiment, a 0.086 M solution of magnesium chloride, 0.25 M ammonium acetate (pH 5.5) solution was prepared and analyzed. See Figure 11.

Urine

Biological matrices contain large concentrations of alkali and alkaline earth metals compared to transition metals. For the determination of trace metals in biological fluids or tissues, the sample must first be acid digested. In this application, 73.4 g of urine were acid digested with 26.6 mL of concentrated nitric acid. A 10-mL aliquot of the digested urine was added to 20 mL of 2 M ammonium acetate, pH 5.5 and the sample analyzed. The results are given in Figure 12.

Oyster Tissue (SRM 1566)

Using microwave digestion for sample dissolution, a United States National Institute of Standards and Technology (NIST) standard reference material (SRM) of oyster tissue was analyzed by chelation concentration. Excellent agreement between the certified and IC values was obtained. See Figure 13 (courtesy of NIST).

Waste Water

Waste waters may contain high levels of alkali and alkaline earth metals. Figure 14 shows the determination of transition metals in an industrial waste water without interferences from the alkali and alkaline earth metals.

CASS-2 Nearshore Water

Chelation IC was used for the analysis of a Canadian seawater reference material. The results are given in Figure 15.

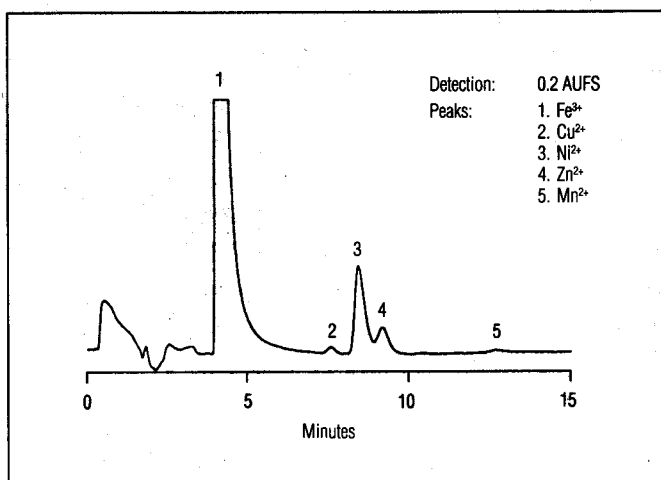

Figure 10 Determination of transition metals in sodium hydroxide using Chelation IC

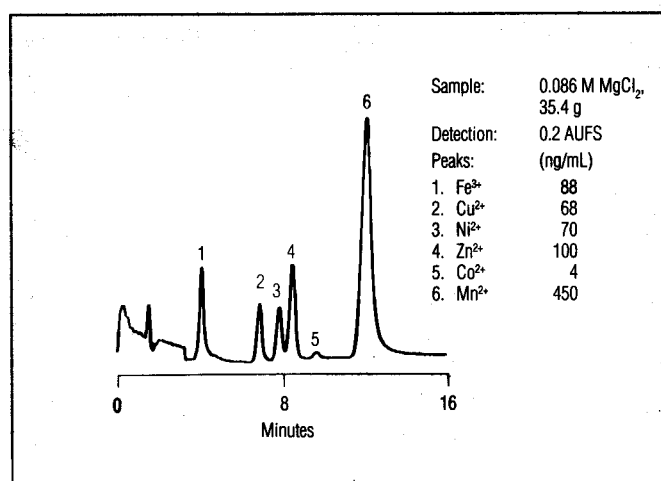

Figure 11 Determination of transition metals in reagent grade magnesium chloride using Chelation IC

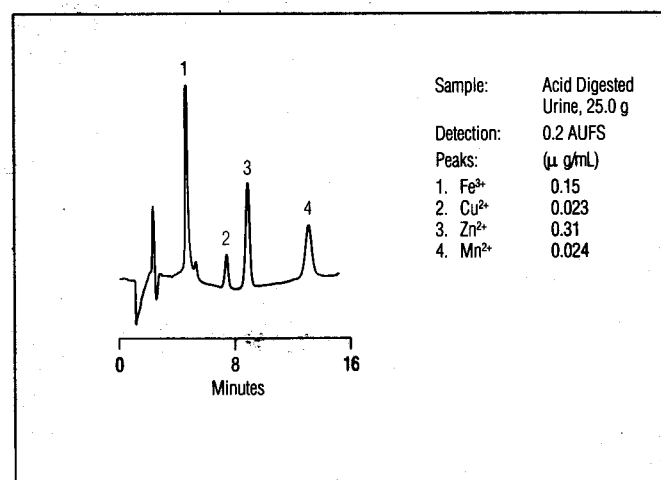

Figure 12 Determination of transition metals in urine using Chelation IC

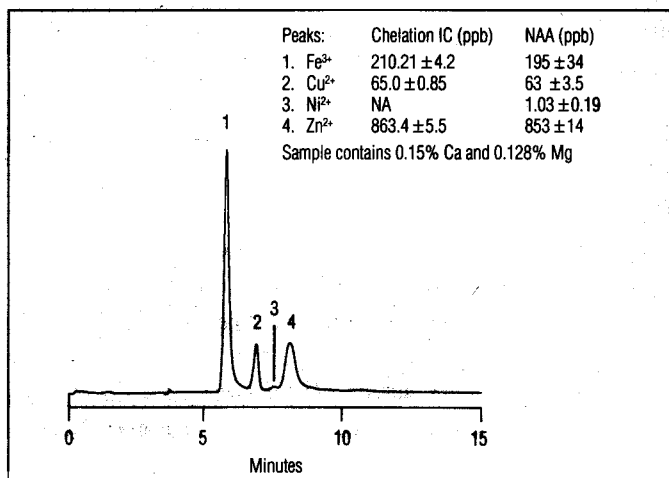

Figure 13 Determination of transition metals in tissue (SRM 1566) using Chelation IC

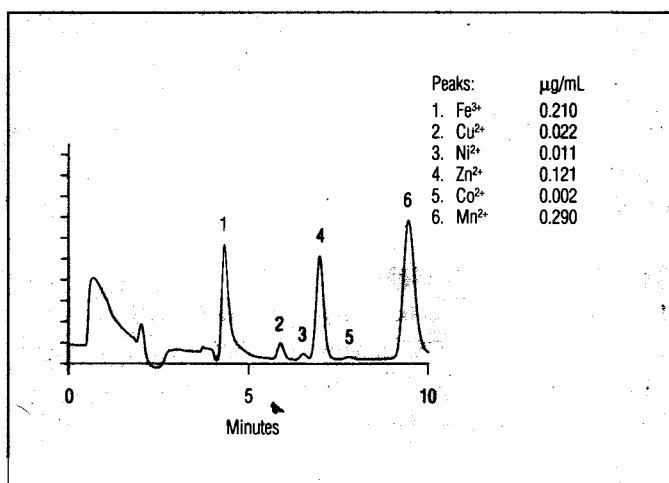

Figure 14 Determination of transition metals in acid-digested waste water by Chelation IC

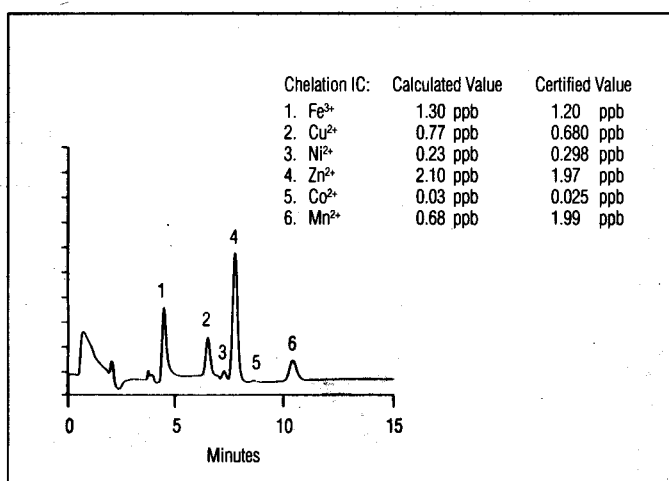

Figure 15 Determination of transition metals in nearshore seawater (CASS-2) by Chelation IC

APPENDIX A: REQUIRED REAGENTS AND STANDARDS

The following reagents are required. Minimum quantities are given in parentheses. Information for ordering ultrapure acids and ammonium hydroxide are given below. All chemicals are reagent grade unless otherwise specified.

Chelation Concentration Eluents

Prepared—Dionex Ultrapure

2 M Ammonium acetate pH 5.5 (1 L, P/N 33440; 6 L, P/N 33441)

2 M Nitric acid (1 L, P/N 33442; 6 L, P/N 33443)

0.1M Ammonium nitrate, pH 3.5 (1 L, P/N 33444; 6 L, P/N 33445)

Chelation Concentration Reagents

Acetic acid, ultrapure

Ammonium hydroxide, ultrapure

Nitric acid, ultrapure

The ultrapure reagents are manufactured by Seastar Chemical and Ultrex Reagents. Seastar reagents are available internationally from Fisher Scientific, who sells these reagents under the OPTIMA® label. Ultrex reagents are available internationally through J.T. Baker and Van Waters and Rogers (VWR).

Chromatographic Reagents

Pyridine-2,6-dicarboxylic acid (PDCA), purified (P/N 39671, 20 g)

Sodium hydroxide, 50% (w/w 0.5 L)

Acetic acid, trace metal grade (0.5 L)

Oxalic acid dihydrate (100 g)

Lithium hydroxide monohydrate, (100 g)

4-(2-pyridylazo) resorcinol, monosodium, monohydrate (P/N 39672, 5 g)

Ammonium hydroxide, trace metal grade (0.5 L)

Sodium bicarbonate (500 g)

2-Dimethylaminoethanol (1 L, Fluka Chemika–Biochemika)

Nitric acid, trace metal grade

Transition metal standards, 1000 ppm, 100 mL each: iron, copper, nickel, zinc, cobalt, manganese, and lead

Eluent and Standards Preparation

Before preparing eluents and standards, thoroughly clean the eluent containers as directed in System Preparation. Be sure that the eluent bottle caps have a white TFE seal and not a black rubber seal. Prepare all eluents directly in the one liter glass eluent containers. Transfer reagents directly from their container. Avoid using pipets or graduated cylinders unless these have been thoroughly cleaned. Do not use stir bars in chelation concentration reagents.

The 0.1 M solutions of nitric acid and ammonium hydroxide are required only if you are going to prepare the chelation concentration eluents. To make these solutions, fill two 500-mL polyethylene containers with 0.2M oxalic acid and let stand for at least four hours. Rinse the containers with deionized water. In one container, add 200 g (200 mL) of deionized water and 4.5 g (3.1 mL) of ultrapure concentrated nitric acid. Bring the final volume to 500 mL with deionized water. Label this solution 0.10 M nitric acid. In the second container, add 200 g (200 mL) of deionized water and 4.4 g (4.7 mL) of ultrapure 20% ammonium hydroxide. Bring the final volume to 500 mL. Label this solution 0.10M ammonium hydroxide. This solution will be used to adjust the pH of E4.

Chelation Concentration Eluents—Transition Metals

Use only ultrapure chemicals and deionized water (<0.5 ppb of each metal) for preparation of these reagents. Caution must be used in preparing this reagent to minimize metal contamination. Do not place anything in the eluent container (including stir bars). When adjusting the pH of the ammonium acetate and ammonium nitrate, do not place the pH electrode in the bulk solution. Instead, take aliquots of the solutions to check the pH.

E1: Deionized water

E2: 2 M Ammonium acetate, pH 5.4 ± 0.1

Place 600 mL of deionized water into a clean 1-L glass eluent container. Tare the bottle and add 121 g (115 mL) of ultrapure glacial acetic acid and mix thoroughly. In a fume hood, slowly add 133 g (148 mL) of 20% ultrapure ammonium hydroxide and mix thoroughly. Agitate the bottle to thoroughly mix the solution. Calibrate a pH meter to pH 7. Pour about 10 mL of the buffer into a small container (scintillation vial, 10 mL disposable beaker) and measure the pH. If the pH is below 5.3, add about 5 mL of ammonium hydroxide to the buffer solution. If above pH 5.5, add 5 g of acetic acid. Adjust the pH of the ammonium acetate to 5.4 ± 0.1 using acetic acid if the pH is

greater than 5.5, or ammonium hydroxide if the pH is less than 5.3. Once the pH is 5.4 ± 0.1, bring to a volume of 1 L. Connect the eluent container to line 2 of the EDM.

E3: 2.0 M Nitric acid

Place 200 mL of deionized water into a clean 1-L glass eluent container. Add 176 g (124 mL) of ultrapure nitric acid. Add deionized water to bring the final volume to 1 L and mix thoroughly. Connect the eluent container to line 3 of the EDM.

E4: 0.10 M Ammonium nitrate, pH 3.4 ± 0.3

Place 200 mL of deionized water into a clean 1-L glass eluent container. Add 8.9 g (6.3 mL) of concentrated nitric acid. Next, add 7.6 g (8.5 mL) of ammonium hydroxide. Add sufficient deionized water to give a final volume of 1 L and mix thoroughly. Calibrate a pH meter to pH 4.0. Take a 10-mL aliquot of the solution and measure the pH. Add either 0.10 M ammonium hydroxide or 0.10 M nitric acid in a 3–5 mL aliquot to the bulk solution to adjust the pH. Continue taking aliquots and adjusting the pH to 3.4 ± 0.3. Connect the eluent container to E4 of the EDM.

Analytical Chromatography

Two eluent systems can be used for transition metal separations with the IonPac CS5 column. The PDCA eluent is used for iron, copper, nickel, zinc, cobalt, and manganese. The oxalic acid eluent is used for lead, copper, cobalt, zinc, and nickel. Cadmium and manganese coelute using the oxalic acid eluent.

PDCA Stock Solution

0.060 M PDCA

0.400 M Sodium hydroxide

Place 200 mL of deionized water into a clean 1-L polyethylene bottle. Add 31.8 g (20.6 mL) of 50% sodium hydroxide. While stirring with a stir bar, add 10.0 g of pyridine-2,6 dicarboxylic acid. Continue to stir for about 10 minutes or until all the PDCA has dissolved. Dilute to 1 L and stir thoroughly. Label 0.060 M PDCA, 0.40 M NaOH.

Acetic Acid Stock Solution

0.90 M Acetic acid

Place 200 mL of deionized water into a clean 1-L polyethylene bottle. Add 54.2 g (51.6 mL) of trace metal grade acetic acid and dilute to 1 L. Label 0.90 M acetic acid.

PDCA Eluent

- 0.006 M PDCA
- 0.040 M Sodium hydroxide
- 0.090 M Acetic acid

To a 1-L glass eluent container, add 100 g (100 mL) of the PDCA and acetic acid stock solutions. Dilute to 1 L with deionized water. Label the container 0.0060 M PDCA, 0.040 M NaOH, 0.090M HOAc. The eluent should have a final pH of 4.6. Connect the eluent to line 5 of the EDM.

Oxalate Stock Solution

- 0.20 M Oxalic acid
- 0.38 M Lithium hydroxide

To a 1-L polyethylene bottle, add 500 g (500 mL) of deionized water. Next add 25.2 g of oxalic acid dihydrate and mix thoroughly to dissolve. Add 16.0 g of lithium hydroxide monohydrate and dilute to 1 L. Mix thoroughly.

Oxalate Eluent (Transition Metals)

- 0.050 M oxalic acid
- 0.095 M lithium hydroxide

To a 1-L glass eluent container, add 250 mL of the oxalate stock solution and dilute to 1 L with deionized water.

PAR Postcolumn Reagent

- 0.5 mM 4-(2-Pyridylazo)resorcinol
- 1.0 M 2-Dimethylaminoethanol
- 0.5 M Ammonium hydroxide
- 0.3 M Sodium bicarbonate

Prepare the PAR directly in the 1-L plastic reagent reservoir container (P/N 37054). To 200 g (200 mL) of deionized water add 31 g (35 mL) of trace metal grade ammonium hydroxide. Next, add 0.12 g of 4-(2-pyridylazo)resorcinol, monosodium, monohydrate and ultrasonicate for five minutes. Add a stir bar and stir for several minutes to ensure that the PAR has completely dissolved. Add 500 g (500 mL) of deionized water and then 89 g of 2-dimethylaminoethanol (DMAE). The solution should turn from red to orange-yellow. If the solution turns bright red upon addition of the DMAE, the DMAE contains metals and should be discarded. Add 25.4 g of sodium bicarbonate and stir thoroughly until dissolved. Fill the reagent container with deionized water up to the threads on the neck and stir. The color of the final solution should be yellow to yellow-orange. Place the reagent container in the reagent reservoir.

APPENDIX B: PREPARATION OF STANDARDS

Standards should be prepared daily. Certain metals, especially iron (III), are not stable at pH 5.5 for more than a day. The standards described below are intended for the determination of metals in the low-ppb (ng/mL) range. If quantification at high levels is required, standards can be prepared at concentrations five times greater than those listed. The standards listed below are intended for use with the PDCA eluent.

Transition Metal Stock Solution

Using a variable volume micropipet, add the following volumes of 1000-ppm atomic absorption standards to a 100-mL volumetric flask.

Metal Ion	Volume (μL)	Final Concentration (μg/mL)
Fe ³⁺	200	2.00
Cu ²⁺	200	2.00
Ni ²⁺	400	4.00
Zn ²⁺	400	4.00
Co ²⁺	400	4.00
Mn ²⁺	400	4.00

Next, add about 1 mL of concentrated nitric acid (ultrapure) and dilute to volume. This stock solution will be used to prepare the calibration standards. The calibration standards can be prepared in 100-mL volumetric flasks or LDPE bottles. Be sure that the flasks or bottles have been thoroughly cleaned.

Single Level Calibration Standard

If you are using a 100 mL volumetric flask to prepare the standard, add 200 μL of stock solution and 15 mL of the 2 M ammonium acetate buffer and bring to volume.

If you are using a polyethylene or Teflon bottle, tare the empty bottle (without the cap) on a top loading balance.

Using a micropipet, add 200 μL of stock solution and 15 g of the 2 M ammonium acetate buffer. Next, add water to give a total mass of 100 g (±0.1 g). This single level calibration standard will have the following concentrations.

Metal Ion	Concentration (ng/mL)
Fe ³⁺	4.0
Cu ²⁺	4.0
Ni ²⁺	8.0
Zn ²⁺	8.0
Co ²⁺	8.0
Mn ²⁺	8.0

For calibration, concentrate at least 5 mL of this solution.

MultiLevel Calibration Standards

The multilevel calibration method recommended uses standards at four concentrations. Using the procedure given in "Single Level Calibration Standard," prepare standards as given below.

Level	Volume, Stock Solution (μL)
L1	100
L2	200
L3	500
L4	1000

The multilevel calibration standards will have the following concentrations of metal ions.

Metal Ion	Concentration (mg/mL)			
	L1	L2	L3	L4
Fe ³⁺	2.0	4.0	10.0	20.0
Cu ²⁺	2.0	4.0	10.0	20.0
Ni ²⁺	4.0	8.0	20.0	40.0
Zn ²⁺	4.0	8.0	20.0	40.0
Co ²⁺	4.0	8.0	20.0	40.0
Mn ²⁺	4.0	8.0	20.0	40.0

Depending on the concentration of metal ions in the sample, the volume of the standards to be concentrated can be varied.

APPENDIX C: SAMPLE LOOP

The 1-mL and 5-mL sample loops are available and supplied with the SCM. If you wish to prepare the sample loop greater than 5.0 mL, use an appropriate length of 1/8-in. I.D. tubing.

To edit the program for a new sample loop, follow these steps:

1. Determine the loop loading time (L) starting from the sample source to the sample loop. If the autosampler is used, determine how much time the autosampler needs to complete the loading step. If the syringe is used, 2.0 minutes is appropriate. Be sure that the sample loop is completely filled. A minimum of 2.0 minutes is required for the first step ($L \geq 2.0$).

2. Determine the sample loading time (C) from sample loop to the MetPac CC-1 column. This value can be obtained by dividing the sample loop size (mL) by the sample pump flow rate (mL/min). For proper sample loading, an additional 1.0 minute is normally included.

Example:

Sample loop size = 7 mL

Sample pump flow rate = 2.0 mL/min

Sample loading time(C) =

$$(7 \text{ mL}/2.0 \text{ mL/min}) + 1.0 \text{ min} = 4.5 \text{ min}$$

3. Enter the L and C values in the work sheet below. Calculate and enter the new time. Enter the new program into the AGP.

Table C1 Gradient Program Work Sheet

t(min) Enter new time	%E1	%E2	%E3	%E4	V5	V6	Flow Rate (mL/min)
0.0	0	100	0	0	1	0	3.0
L	0	100	0	0	0	1	2.0
L+C	0	100	0	0	1	0	3.0
L+C+2.0	0	100	0	0	1	0	1.2
L+C+2.1	50	0	50	0	1	1	1.2
L+C+7.0	50	0	50	0	1	1	1.2
L+C+7.1	0	0	0	100	1	1	2.0
L+C+8.0	0	0	0	100	0	0	3.0
L+C+10	0	0	0	100	0	0	3.0
L+C+10.1	0	0	100	0	1	0	4.0
L+C+11	0	0	100	0	1	0	4.0
L+C+12	0	0	100	0	1	0	4.0
L+C+13	0	100	0	0	1	0	0.0

*begin sample analysis